

Surface Temperature  
1960-1991

## Atmospheric Sciences 211

- **Climate of the present.** We will examine the nature of the global climate system and the factors controlling its present state. Topics covered will include the global energy balance, the greenhouse effect, atmospheric circulation, the role of oceans and ice in climate, and the "natural" carbon cycle.
- **Climate of the past.** In this part of the class we will discuss how climate changed in the past on timescales ranging from billions of years to thousands of years. And we will use this information to help understand what future climates might be like.
- **Climate of the future.** How will climate change over the next 100 years, and how do we know this? Should you be concerned? *What are technologies for potentially addressing human-induced global climate change?*

[www.atmos.washington.edu/academics/classes/2012Q4/211/](http://www.atmos.washington.edu/academics/classes/2012Q4/211/)

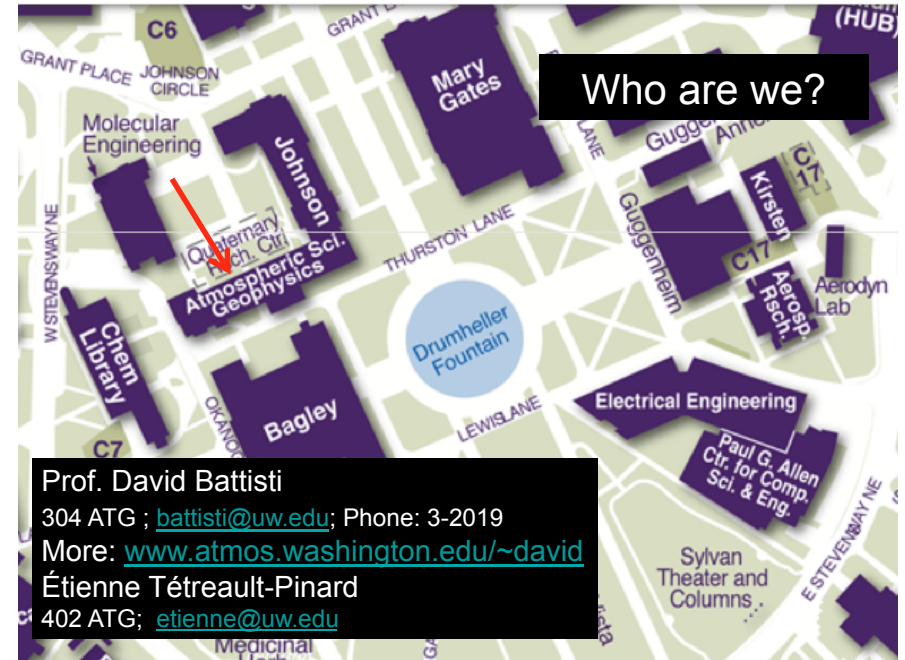

## About Me

### Prof. of Atmospheric Sciences

BS. In Physics, MS. In Oceanography, Ph.D. in Atmospheric Sciences

#### Scientific Interests:

- Year-to-Year Climate Variability (e.g., El Nino)
- Past Climates (e.g., Eocene, Ice Ages)
- Impacts of Climate Variability and Climate Change on Global Food Production

#### Sea Surface Temperature Anomalies

24-31 Aug 2012

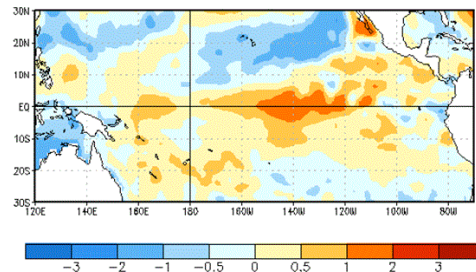

## Course Goals

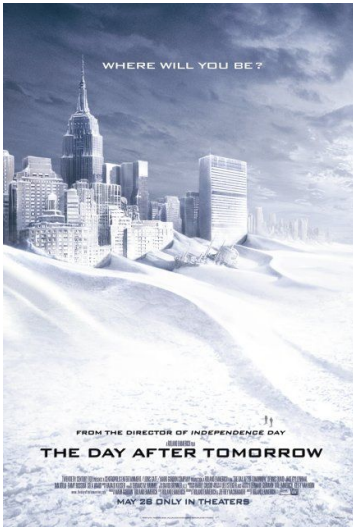

1. Develop an understanding of how the climate system works, how it has changed in the past, and how it is now being changed by human activity.
2. Learn skills to analyze and critically evaluate public discussions of climate issues.

## What this course is/isn't about

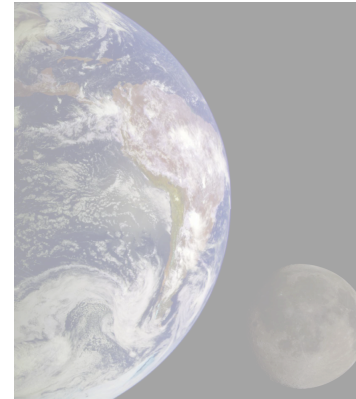

YES: Science: the what, how, and why of climate and climate change

NO: philosophies, values, politics, etc

## Course Overview

### The Climate System (Present)

- Tools: Radiative Transfer & Energy Balance
- Earth's Energy Balance & Climate
- Tools: Force Balance and Winds
- General Circulation of the Atmosphere
- Regional Climates

### Climate Change (Past-Present)

- How we know pre-instrumental climate
- Orbital Forcing & the Ice Ages
- Solar and Volcanic Forcing
- The natural carbon cycle and past warm climates
- The Human Influence on the climate of the 20<sup>th</sup> Century

### Global Warming (Future)

- Projected forcing and climate response

## Things we will understand

- Why is Southern California so dry and Seattle so wet?

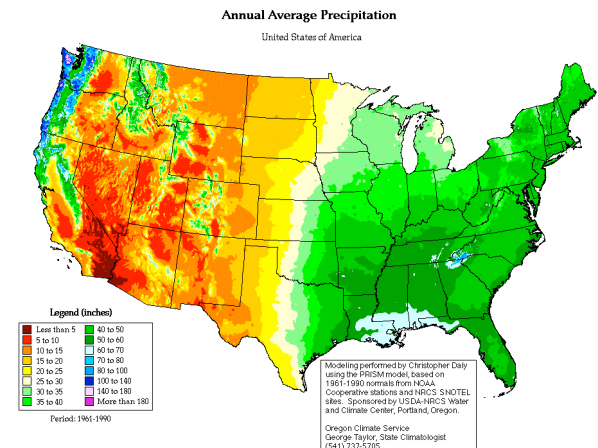

## Things we will *understand*

- Why is Europe so warm in winter compared to New England?
  - The Gulf Stream
  - 350M Europeans release much more CO<sub>2</sub> than 20M N'Englanders and Canadians
  - The Rocky Mts

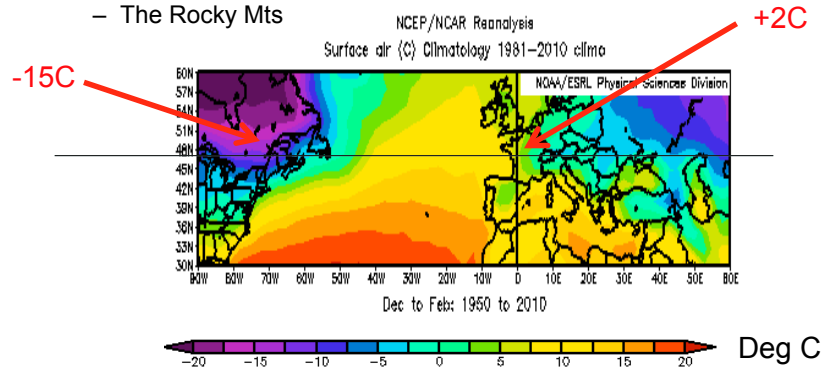

## Annual Global Average Surface Temperature

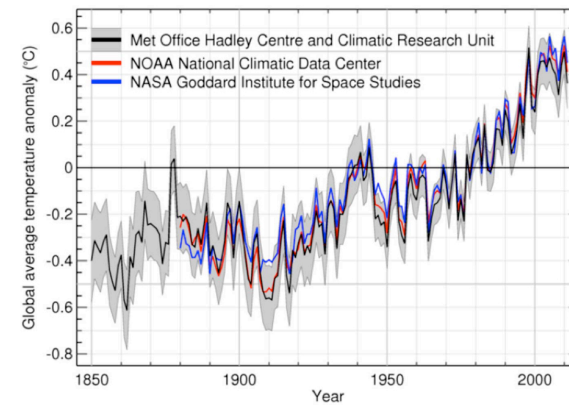

- How do we *know* the 20<sup>th</sup> Century trend in is not due to natural variability? To changes in the Sun's output?

## Carbon Dioxide in the Atmosphere

Atmospheric CO<sub>2</sub> at Mauna Loa Observatory

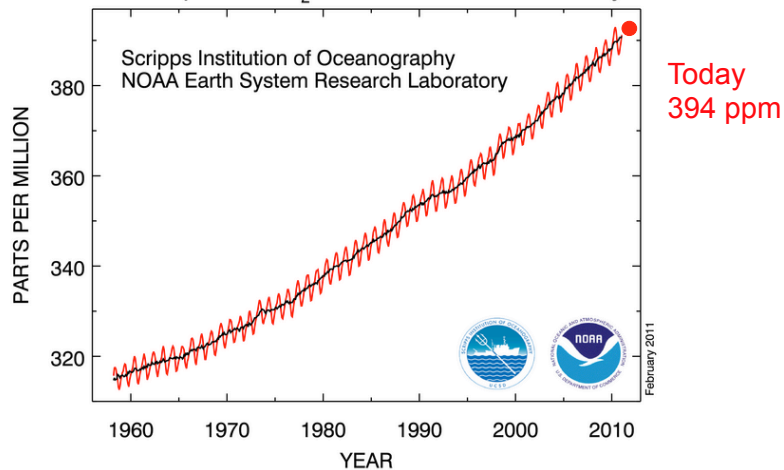

How do we know the 20<sup>th</sup> Century trend in CO<sub>2</sub> is not natural?

## Atmospheric Carbon Dioxide

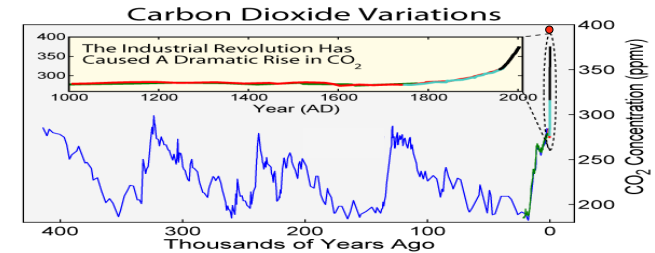

- What does the geological record tell us about the climates of the past, when CO<sub>2</sub> was much *lower* than today?

## CO<sub>2</sub> and Temperature at the S. Pole (Vostok St)

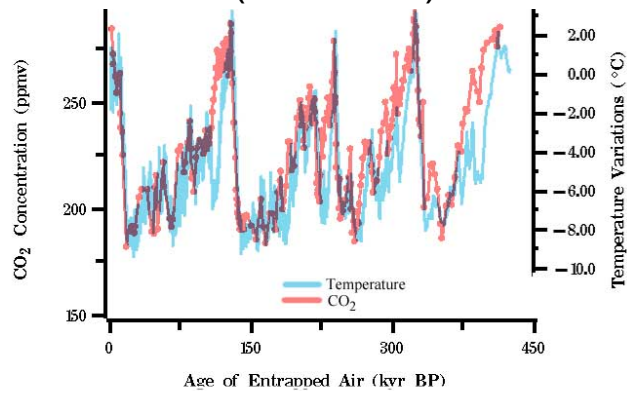

At the S. Pole, temperature goes hand-in-hand with CO<sub>2</sub>: high CO<sub>2</sub> goes with high temperature.

What does this imply about the globe? About causality?

## Things we will *understand*: the Great Ice Ages

- The Ice Ages lasted 2.6 Myr BP to about 10,000 yrs ago

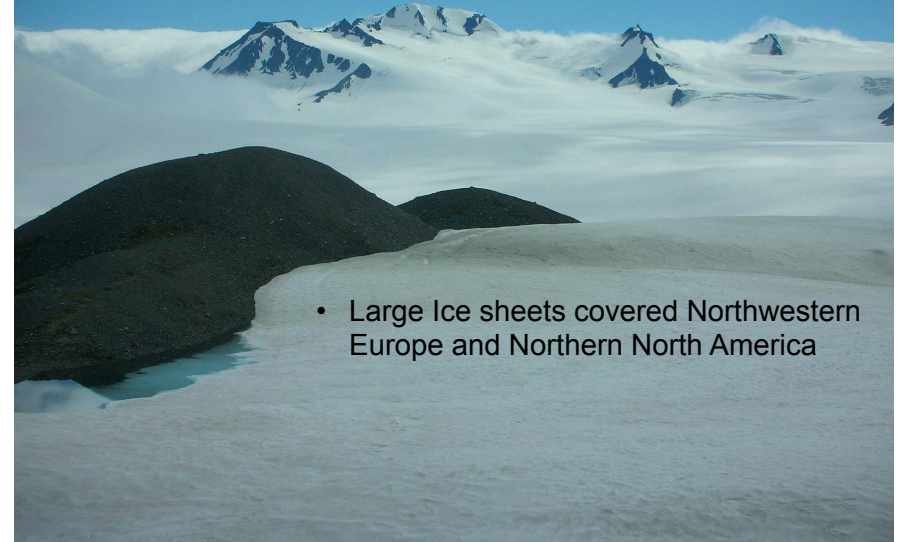

- Large Ice sheets covered Northwestern Europe and Northern North America

## Things we will *understand*: the Great Ice Ages

- The Ice Ages lasted 2.6 Myr BP to about 10,000 yrs ago

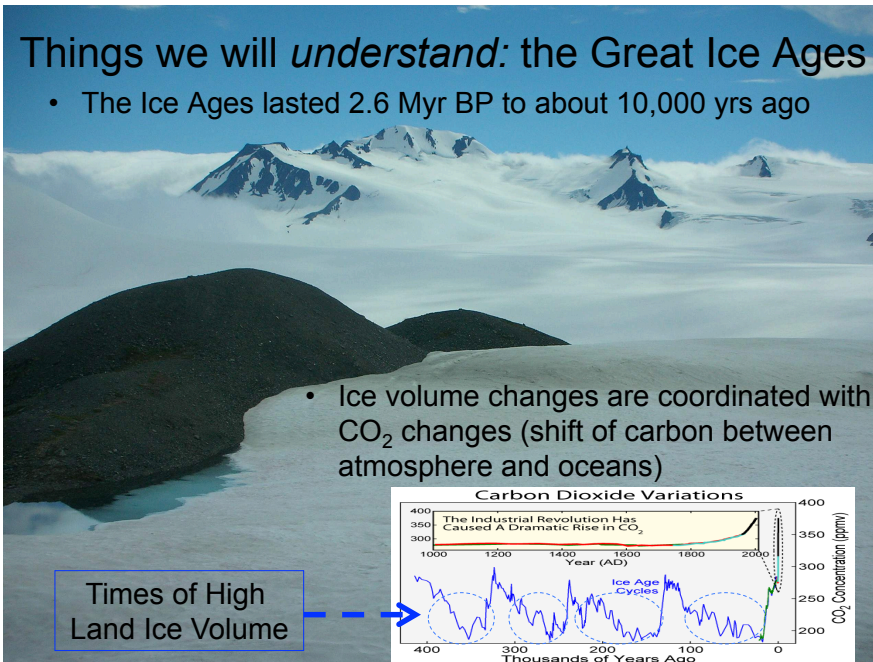

- Ice volume changes are coordinated with CO<sub>2</sub> changes (shift of carbon between atmosphere and oceans)

## Things we will *understand*: the Great Ice Ages

- The Ice Ages lasted 2.6 Myr BP to about 10,000 yrs ago



- The Ice Ages are *caused* by orbitally induced changes in northern hemisphere summer insolation
  - Changes in CO<sub>2</sub> act enhance the temperature and land ice changes due to the insolation changes (a positive feedback)

# Carbon Dioxide in the Atmosphere

**GEOCARB II model**  
(black line; shaded area encloses model uncertainty)

**Estimate from plant stomata & C<sup>13</sup>/C<sup>12</sup>**  
(vertical bars)

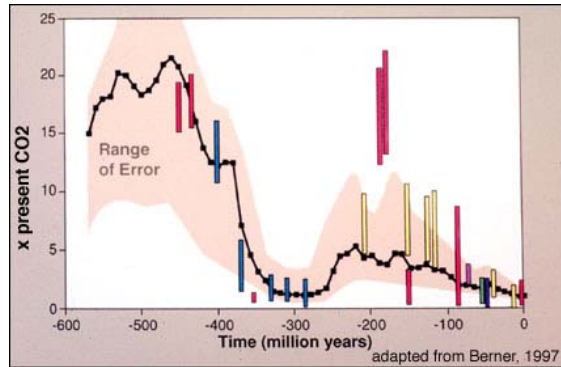

- CO<sub>2</sub> has been much higher in the past than today. How do we know the 20<sup>th</sup> Century trend in CO<sub>2</sub> is not due to natural causes?

# Atmospheric Carbon Dioxide

- What does the geological record tell us about the climates of the past when CO<sub>2</sub> was much higher than today?

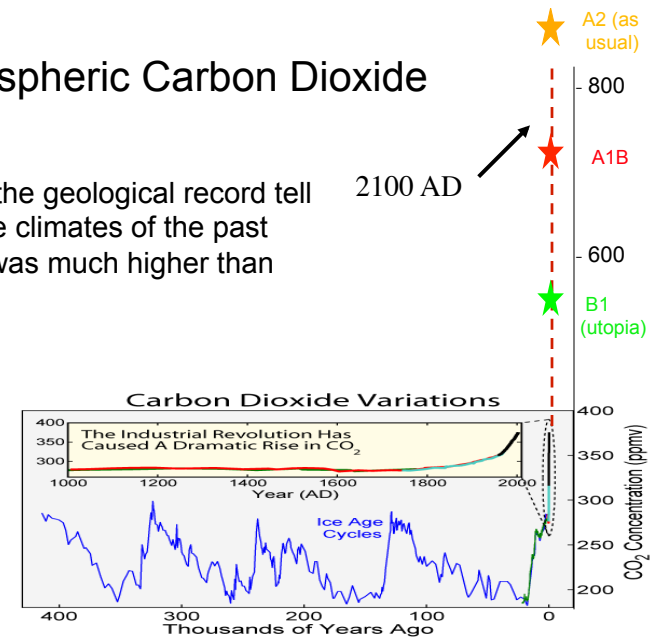

# Global Warming Projections

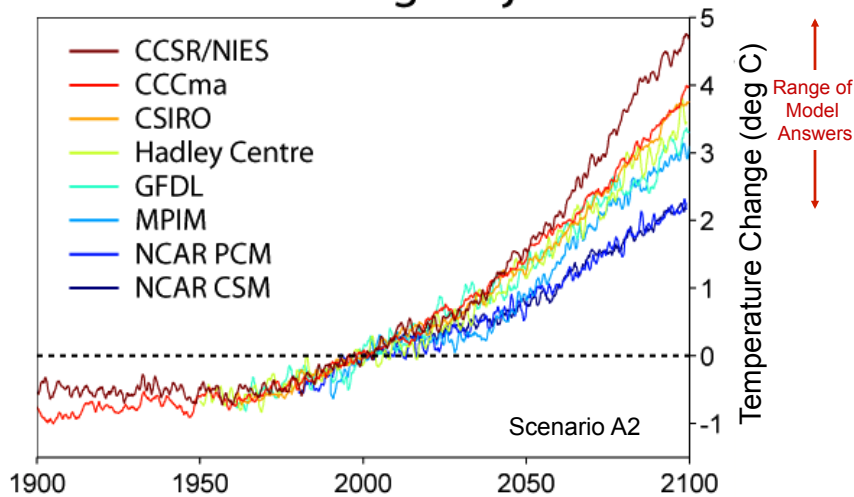

How are these projections made and what do they say about the climate at the end of this Century?

In 100 years, the atmospheric CO<sub>2</sub> will reach 500-1000 ppm, which was last experienced during the EOCENE (55 to 36 million years ago)



- The Eocene climate was warm, even at high latitudes:
- palm trees flourished in Wyoming and Antarctica was a pine forest
  - crocodiles lived in the Arctic
  - deep ocean temperature was 55°F (today it is ~35°F)
  - sea level was at least 300 feet higher than today

\* Climate models with mid-range climate sensitivity simulate an Eocene that is much too cold compared to the fossil records

## Very Tentative Syllabus

Sept 24-27	Introduction; Origin of Earth's Atmosphere; Atmosphere Composition Today
Oct 1-4	Heat and Temperature; Heat Forms and Transport; Radiation; Concepts in EM Radiation; Solar Radiation and the Earth; Albedo
Oct 8-11	Energy Balance; Greenhouse gases and the Greenhouse Effect
Oct 15-18	Greenhouse Effect (cont.) Seasonal Temperature Cycles; Pressure Force, Hydrostatic Balance; Coriolis Effect and Geostrophic Wind; Jet Streams;
Oct 22-25	General Circulation of the Atmosphere; The Role of Mountains in Climate; The Role of the Ocean in Climate

### *Prerequisites & Required Materials*

- Math is the language of the natural sciences
- You will see and learn to use a *few* equations
- This course and your grades are based on concepts (NOT mathematical ability)
- Textbook: Kump, Kasting, Crane, 3<sup>rd</sup> edition (2010) *The Earth System*

### *Logistics*

- Lectures here MTWTh 10:30-11:20
- Discussion/Quiz Sections Friday  
10:30 JHN 111 or 11:30 JHN 175

## Very Tentative Syllabus

Oct 29- Nov 1 Midterm 1 <sup>st</sup>	The Cryosphere Today; Ice Ages and How We Know They Happened; Milankovitch Theory; Precessional Forcing
Nov 5-8	The Carbon Cycle and Warm Climates of the Past
Nov 13-15 (12 <sup>th</sup> Holiday)	Natural and Human Induced Forcing and their Impact on Climate of the 20 <sup>th</sup> Century
Nov 19-21 (22 <sup>nd</sup> Holiday)	The 20 <sup>th</sup> Century Climate (cont)
Nov 26-29	Projected Climate Change (today to 2100 and beyond)
Dec 3-6	Geo-engineering; wrap-up

### Assessment & Grading Policy

#### • **Assessment**

- Homework and Quizzes 35%
  - Mid-Term Exam (Nov 1) 30%
  - Final Exam 35%
- Tentative: Monday Dec 10 830-1020, OTB 014

#### • **Grading Method**

- Likely course mean 2.8 – 3.2 (B- to B)
- Curve if necessary

## Assessment & Grading Policy (cont)

- There will be no makeup exams except in case of serious illness, death in the family or something of that nature. You must be excused by Prof. Battisti in advance of the date of the exam.
- **Plagiarism - Working Together**
  - see UW policy on plagiarism
  - discussions are encouraged!
  - on your own for exams, homework, etc

## Course Guidelines and Philosophy



### UW Credit Hours

- 2hrs/week outside per credit hour
- 15 hrs/week dedicated to this class (5 in class, 10 outside)

### Lectures/Discussion

- **FOR YOUR BENEFIT!**  
Stop me, ask questions!
- **Mix of writing on board and powerpoint slides**
- **Comfortable Atmosphere**  
*Let me know immediately*

We want you to do well!

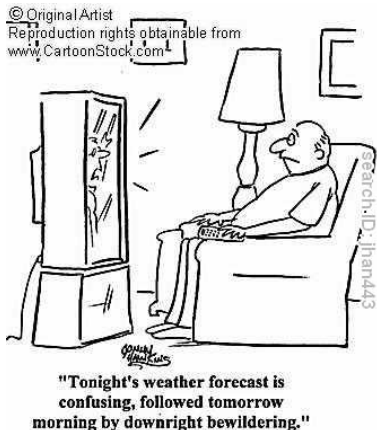

1. **COME TO CLASS**
2. **TAKE GOOD NOTES**
3. **REVIEW YOUR NOTES**
4. **TALK TO YOUR CLASSMATES, YOUR TA AND ME**
5. **TEST YOURSELF**
6. **RELAX**

### Reading for this week

- Chapter 1
- Chapter 10
- Note: you can skip the blue-boxed text in both chapters

**GET YOUR QUESTIONS ANSWERED!**

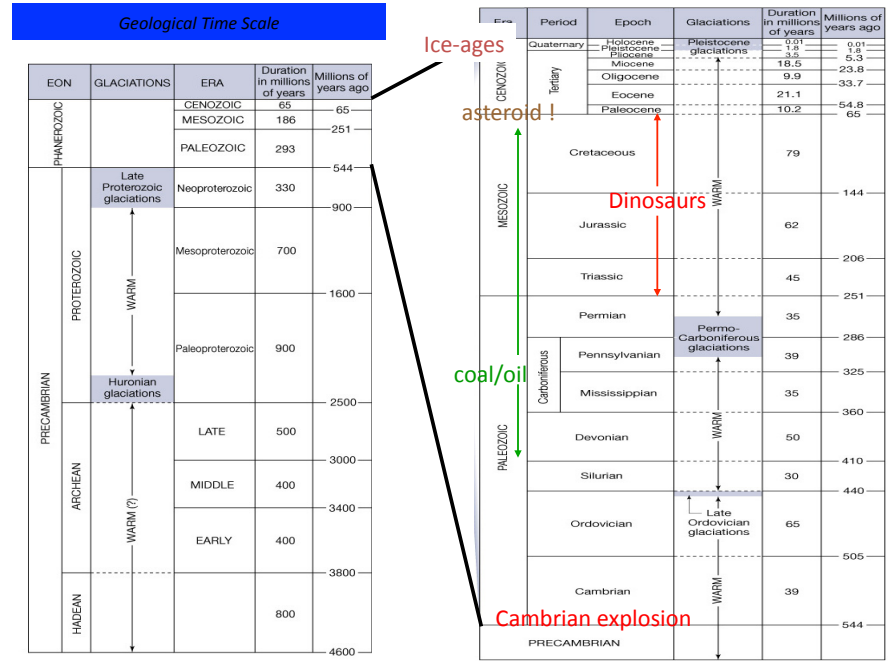
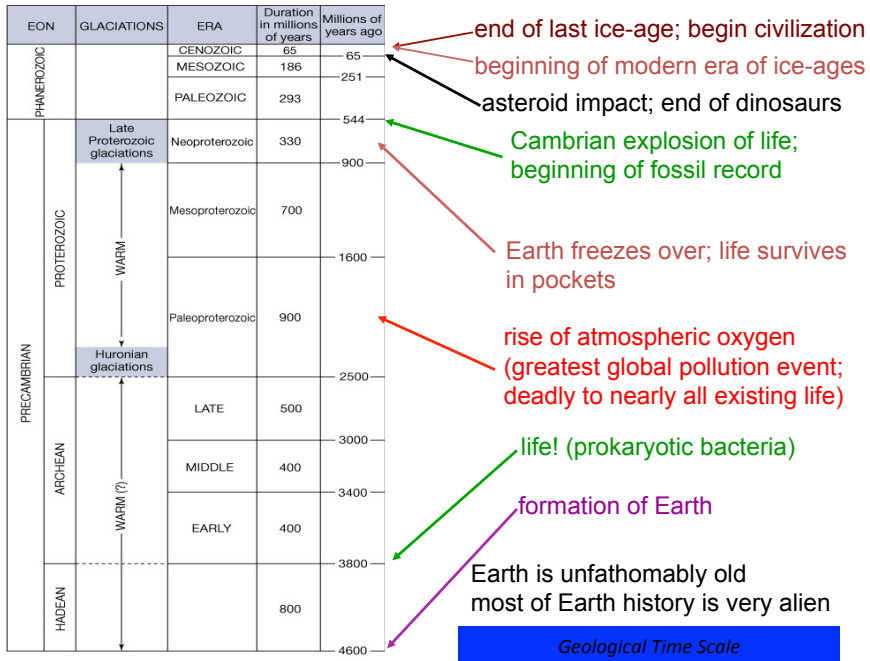

## Descent into the Ice-Ages

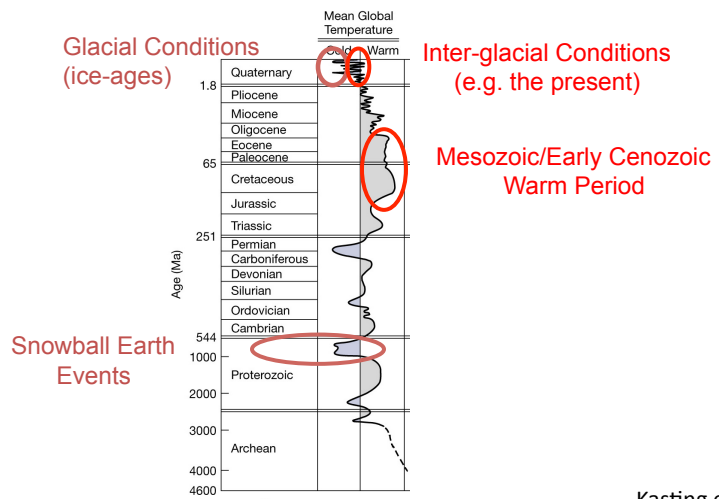

Kasting et al

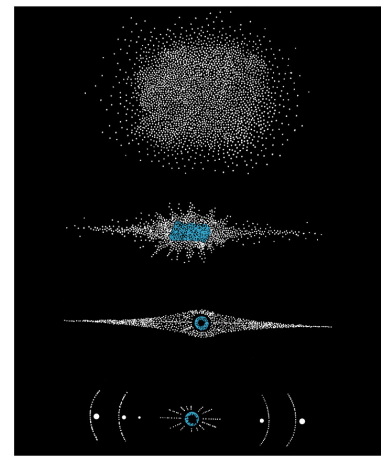

© 2010 Pearson Education, Inc.

# Stromatolites



Similar to those in the fossil record (3.5 Byr BP) that use anoxygenic photosynthesis

# Atmospheric Carbon Dioxide

- Nature's *Long-term Carbon Cycle* is a balance between
  - Removal of CO<sub>2</sub> from the atmosphere by rock erosion (C goes into ocean/sediments)
  - Input of CO<sub>2</sub> from volcanoes
  - The former depends on climate (thus on CO<sub>2</sub>); the latter depends on outgassing rate (plate tectonics)
  - Time scale of adjustment: millions of years.

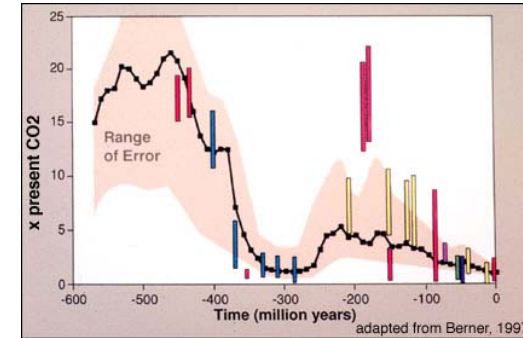

# Earth's Atmosphere Today

Permanent Gases			Trace Gases			
Gas	Symbol	Percent (by Volume) Dry Air	Gas (and Particles)	Symbol	Percent (by Volume)	Parts per Million (ppm)*
Nitrogen	N <sub>2</sub>	78.08	Water vapor	H <sub>2</sub> O	0 to 4	
Oxygen	O <sub>2</sub>	20.95	Carbon dioxide	CO <sub>2</sub>	0.037	376* 394
Argon	Ar	0.93	Methane	CH <sub>4</sub>	0.00017	1.7
Neon	Ne	0.0018	Nitrous oxide	N <sub>2</sub> O	0.00003	0.3
Helium	He	0.0005	Ozone	O <sub>3</sub>	0.000004	0.04†
Hydrogen	H <sub>2</sub>	0.00006	Particles (dust, soot, etc.)		0.000001	0.01–0.15
Xenon	Xe	0.000009	Chlorofluorocarbons (CFCs)		0.00000002	0.0002

\*For CO<sub>2</sub>, 375 parts per million means that out of every billion air molecules, 375 are CO<sub>2</sub> molecules.  
 †Stratospheric values at altitudes between 11 km and 50 km are about 5 to 12 ppm.

**Note: All of the trace gases are greenhouse gases!**

Also important: aerosols - small particles of material in the atmosphere (dust, soil salts, soot, ...)

How do we explain the different climate of these three terrestrial planets?

Venus (runaway greenhouse)      Earth ("just right")      Mars (virtually no greenhouse)



Color	Orange	Blue	Red
Dist to Sun	108 x 10 <sup>9</sup> km	150 x 10 <sup>9</sup> km	228 x 10 <sup>9</sup> km
Surf. Temp	460°C	15°C	- 60 °C
Main Gas	CO <sub>2</sub>	N <sub>2</sub> , O <sub>2</sub>	CO <sub>2</sub>
Surf. Pressure	93 bars	1 bar = 1000mb	0.06 bar

# Outline so far

- History of the composition of Earth's atmosphere
- Energy Temperature and Heat
- **Electromagnetic Radiation and Greenhouse Effect**
  - Everything emits radiation ( $T > 0\text{k}$ )
  - Radiation travels in waves
  - Spectrum of radiation emitted from the Sun and Earth
  - Absorption, Reflection (albedo) and Transmission
  - Absorbers and Emitters (emissivity; Kirchhoff's law)
  - Blackbody Radiation (Stefan Boltzman Eq. and Wein's Law)
  - Radiative Equilibrium (energy in = energy out)
  - Greenhouse Effect
  - A detailed look at the Earth's energy balance

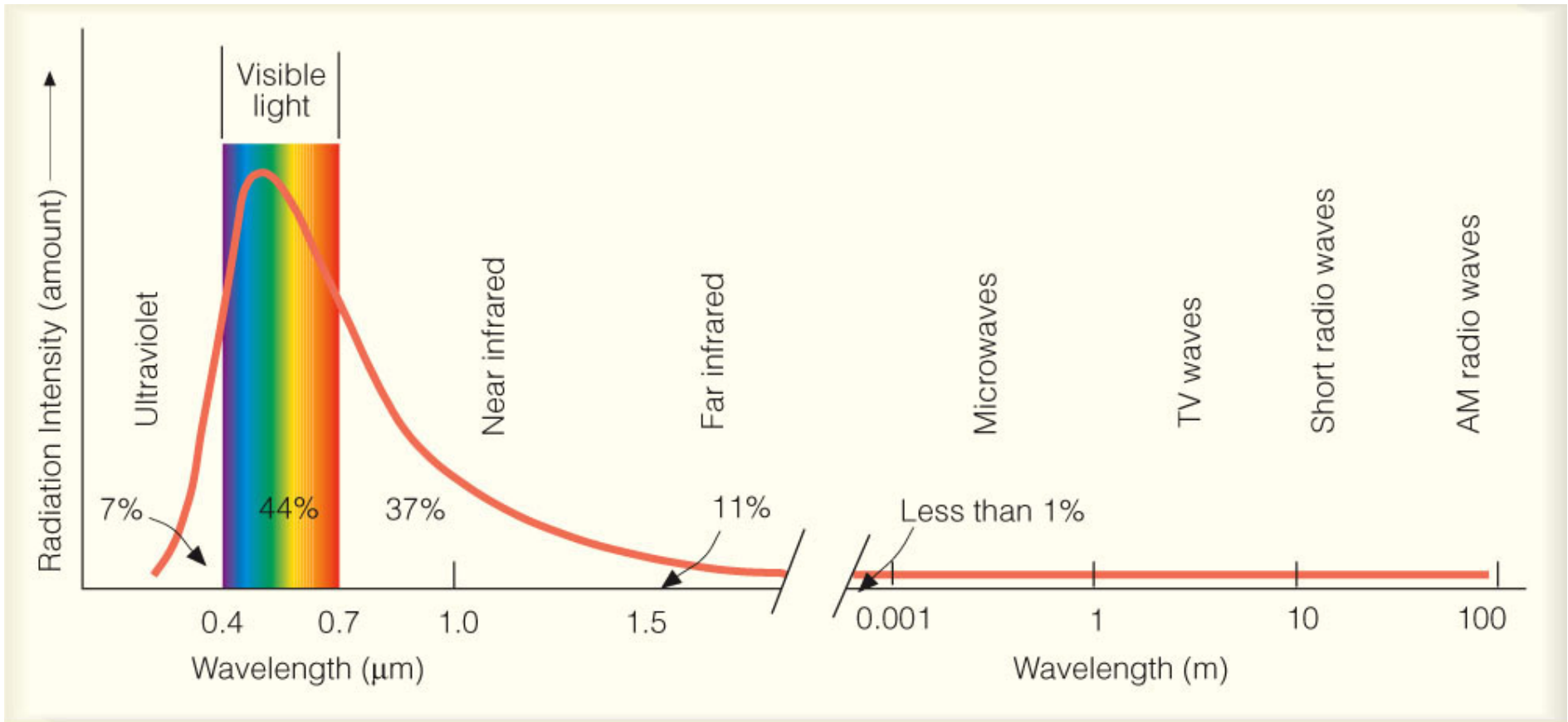

© 2007 Thomson Higher Education

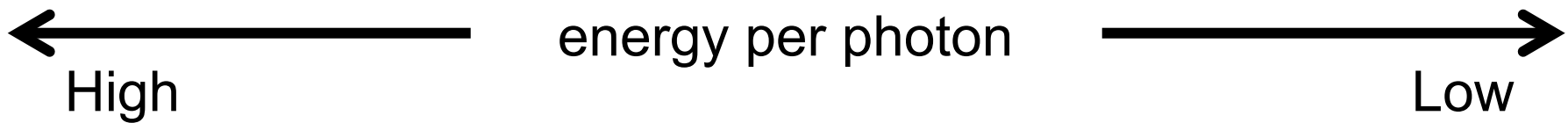
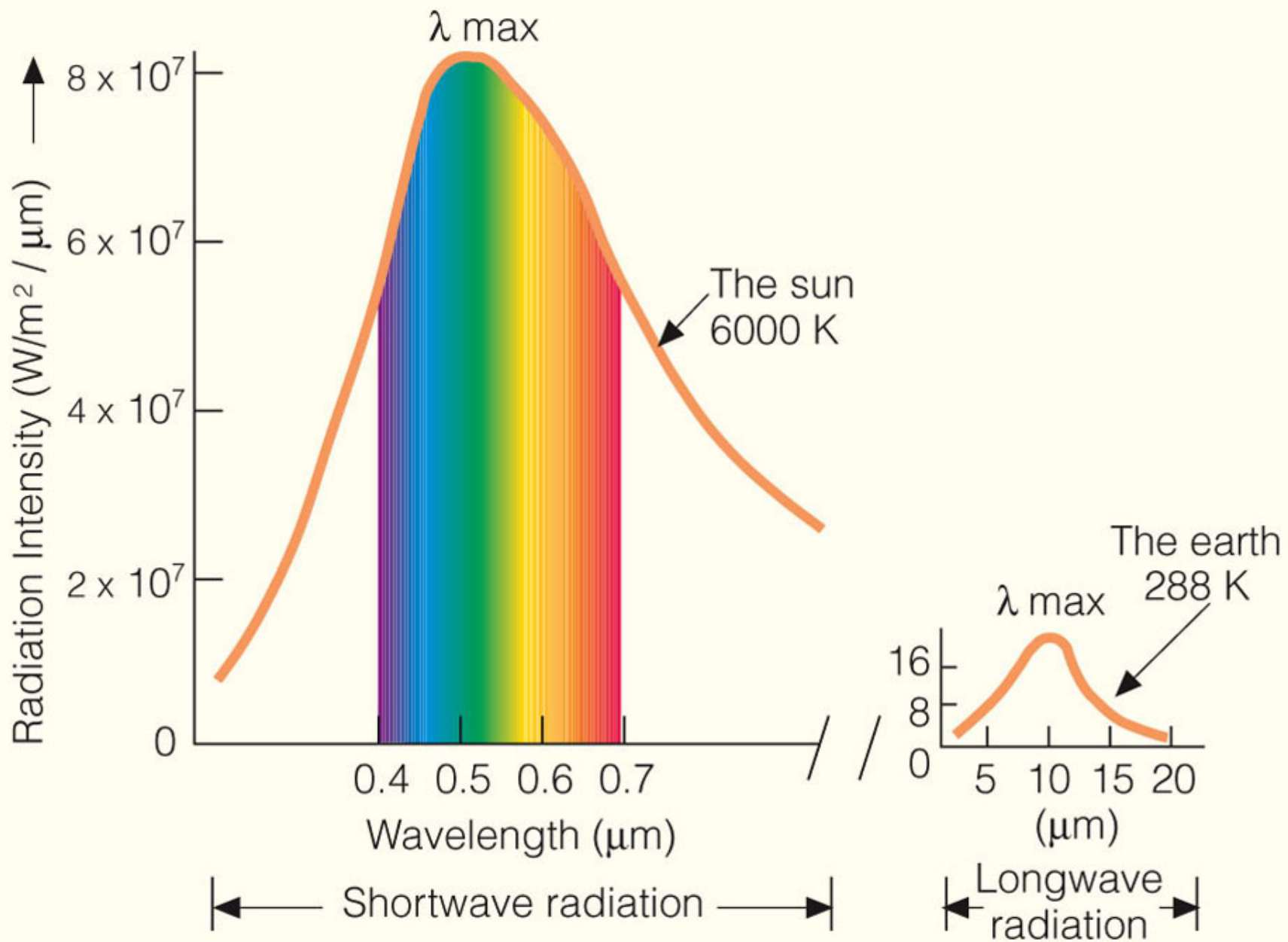
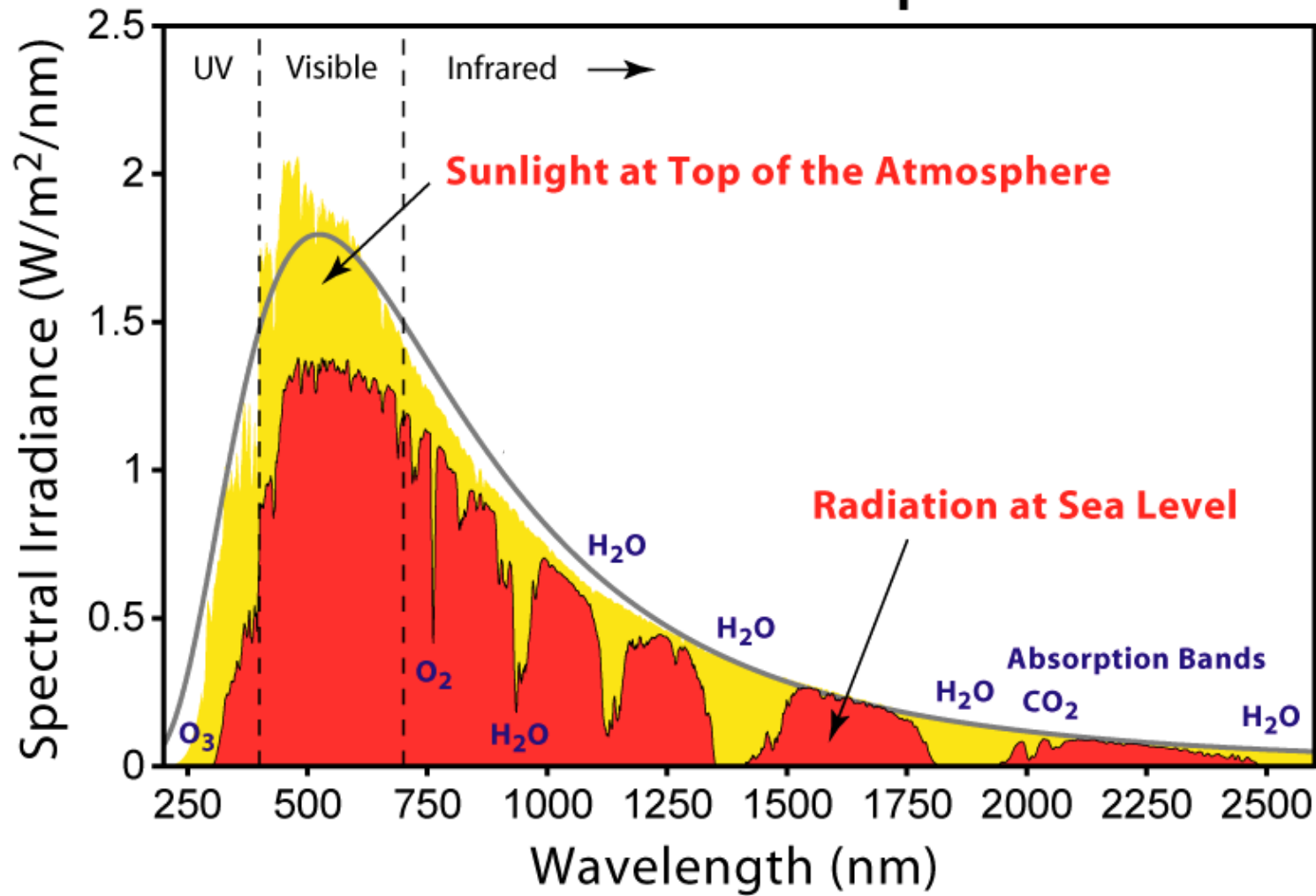

Fig. 2-9, p. 37



# Solar Radiation Spectrum



# Atmospheric Carbon Dioxide

- What is your gut feeling? Will we actually burn enough coal/oil/biomass 2100 AD to reach 850ppm CO<sub>2</sub> by the end of this century (more than double today's value and three times pre-industrial levels)?

Year	CO2 in atmos
1850	280 ppm
2010	392 ppm
2100	???

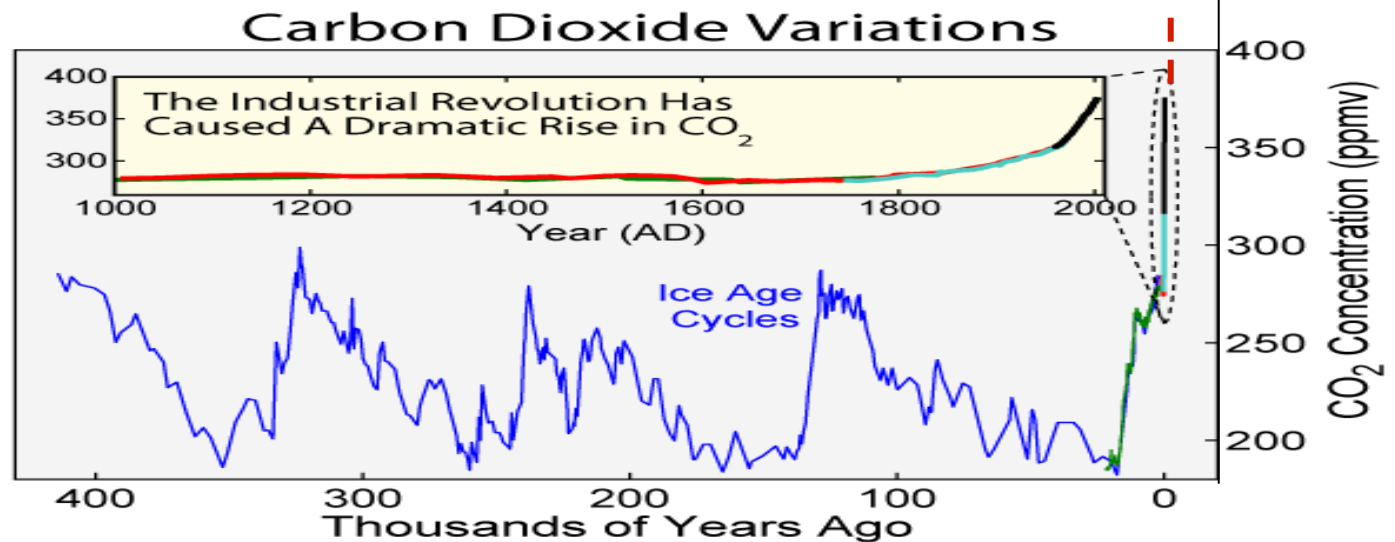

★ A2 (as usual)

★ A1B

★ B1 (utopia)

# Blackbody Radiation

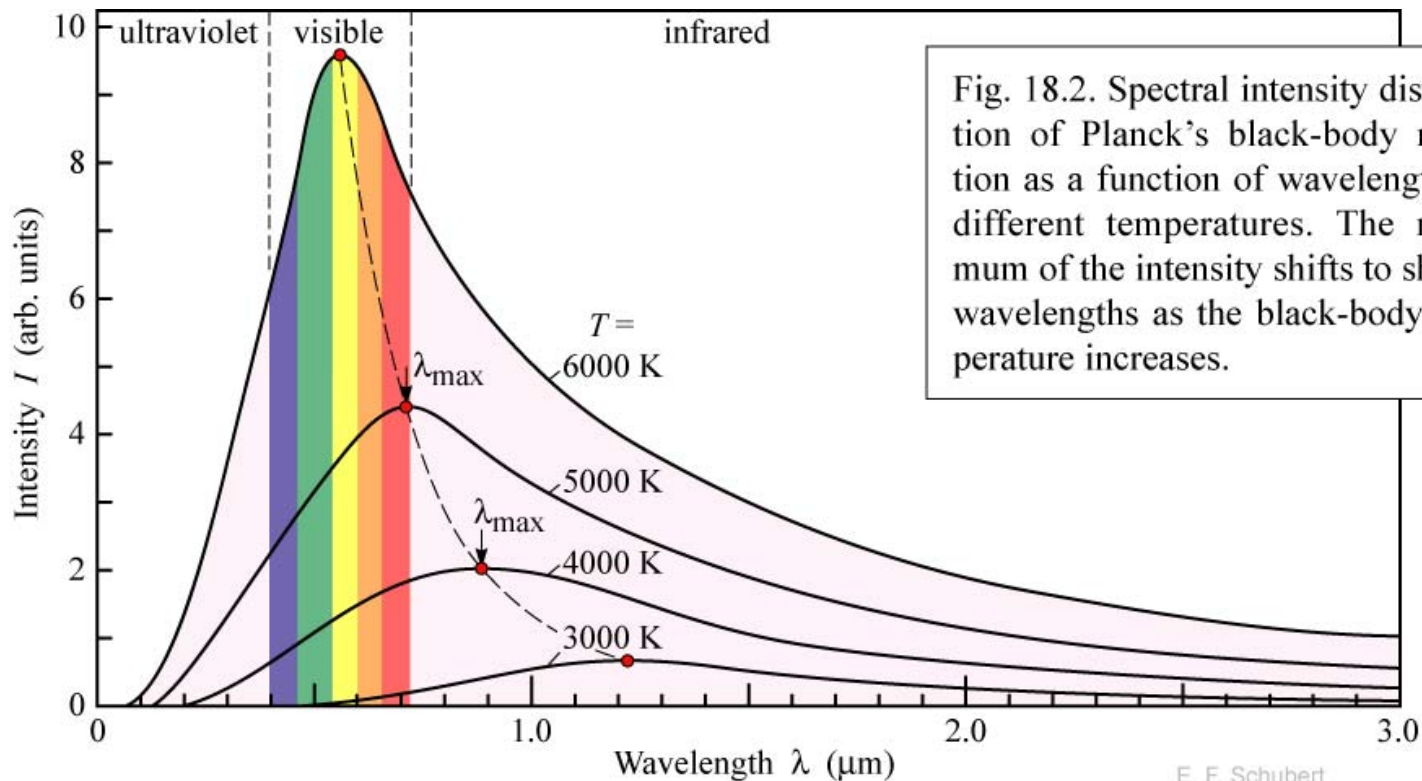

Fig. 18.2. Spectral intensity distribution of Planck's black-body radiation as a function of wavelength for different temperatures. The maximum of the intensity shifts to shorter wavelengths as the black-body temperature increases.

# Equilibrium Temperature of Earth (Energy In = Energy Out)

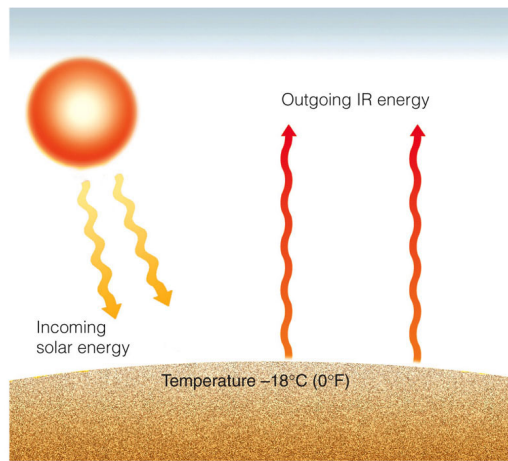
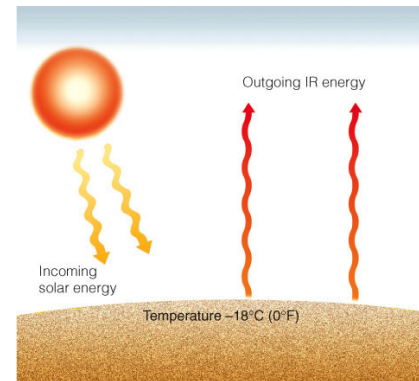

Fig. 2-12a, p. 42

## No Greenhouse Effect



(a) Without greenhouse effect  
© 2007 Thomson Higher Education

## With Greenhouse Effect

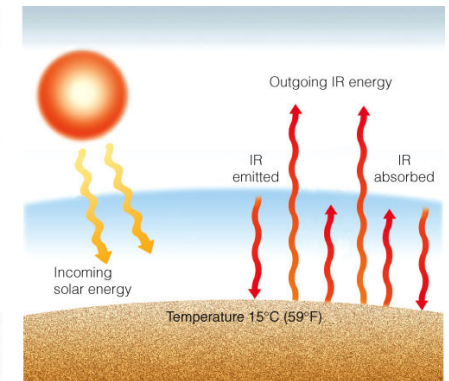

(b) With greenhouse effect

Fig. 2-12, p. 42

## Solar Radiation Spectrum

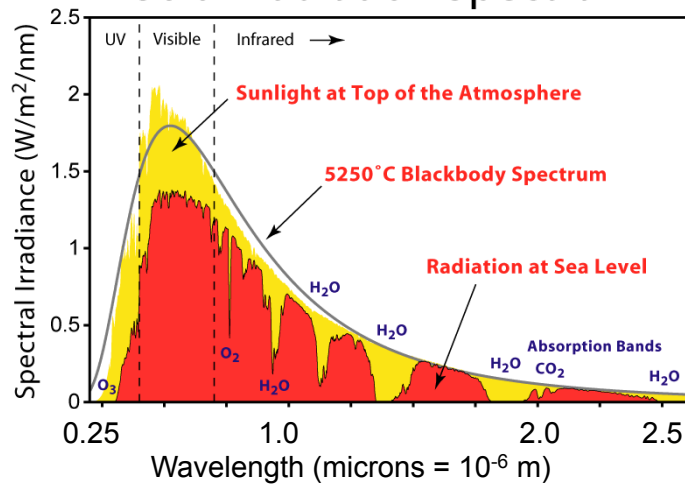

Black Line - Perfect Blackbody at 5250 °C

## Absorptivity of the Atmosphere

Water vapor and carbon dioxide absorb infrared

Ozone absorbs UV and a small amount of visible

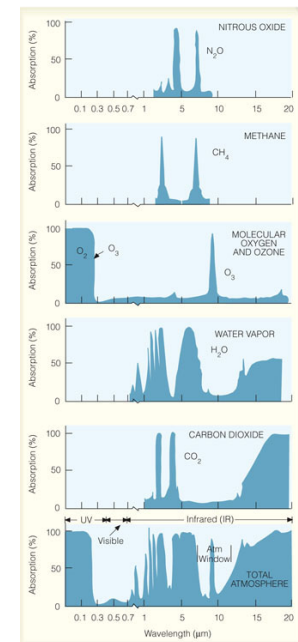

© 2007 Thomson Higher Education

# Absorptivity of the Atmosphere

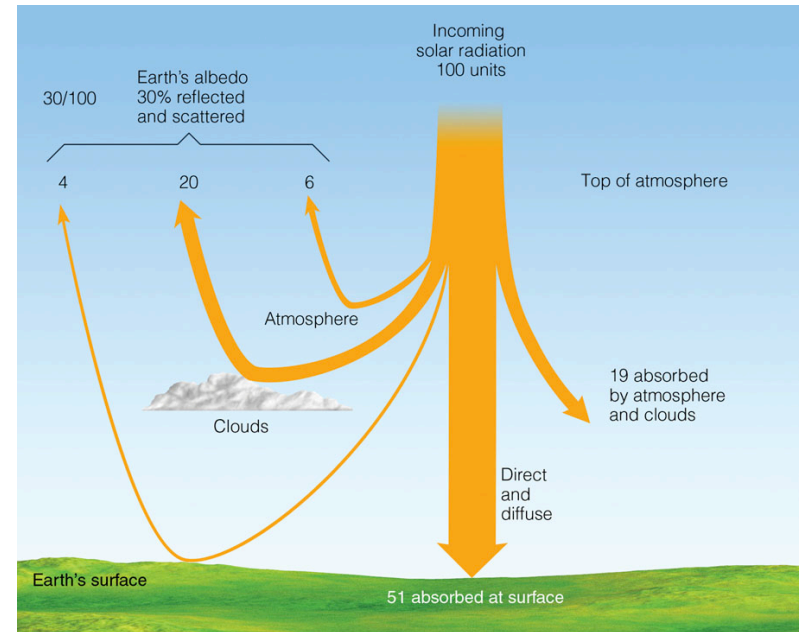
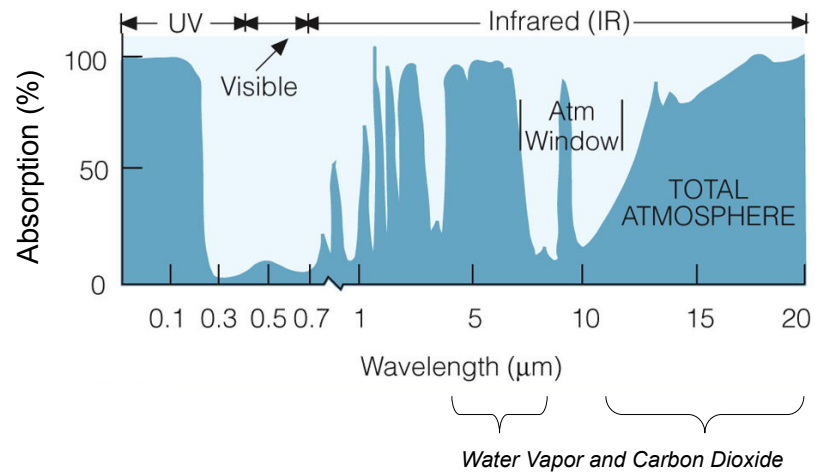

© 2007 Thomson Higher Education

Fig. 2-15, p. 45

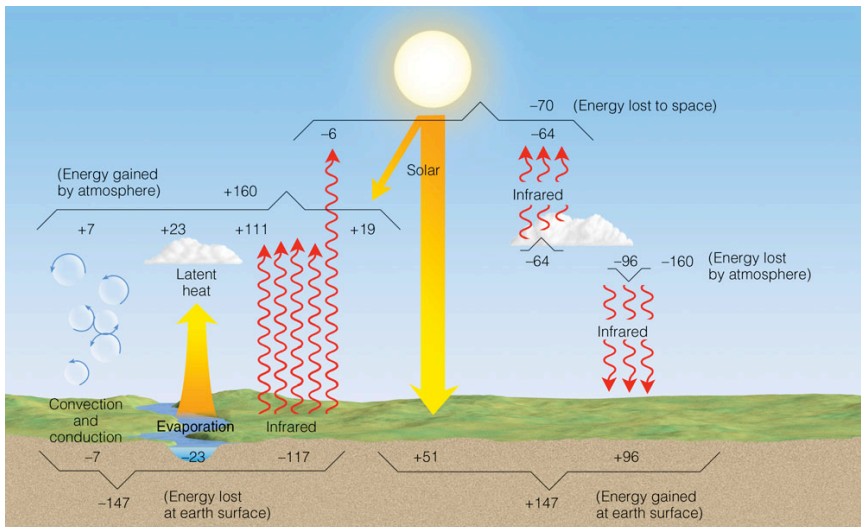

© 2007 Thomson Higher Education

Fig. 2-16, p. 47

# Periodic Temperature Cycles

- The Annual Average Equator-to-Pole Temperature difference
  - Due mainly to differences in Solar energy absorbed at the surface, which is mainly due to
    - Differences in *intensity* (energy per unit area) of insolation at the top of the atmosphere (2/3)
    - Distribution of clouds vs. latitude (more in midlats and polar regions, less in tropics) that reflect sunlight (1/3)
- The Diurnal (day-night) Cycle of Temperature
- The Annual Cycle of Temperature
- Maritime vs. Continental
- Odds and Ends
- Summary of Temperature Controls

# Why are Tropics warmer than Polar Regions?

Ingredient One: Differences in the angle of Incidence of incoming insolation

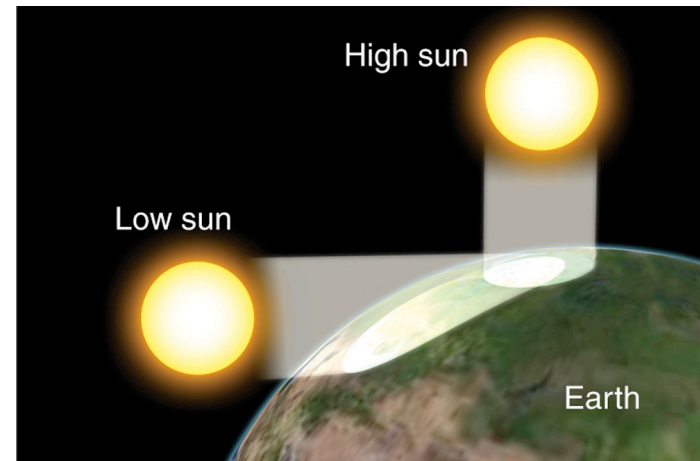

© 2007 Thomson Higher Education

# Why are Tropics warmer than Polar Regions?

Ingredient Two: Latitudinal differences in objects that reflect energy back to space

Northern Hemisphere Insolation on June 21

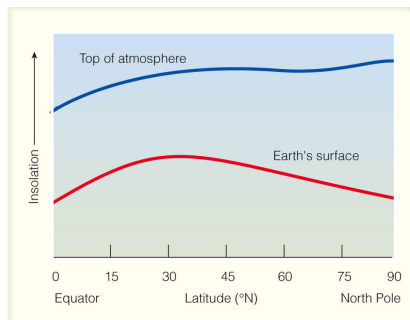

© 2007 Thomson Higher Education



# The Earth's Albedo

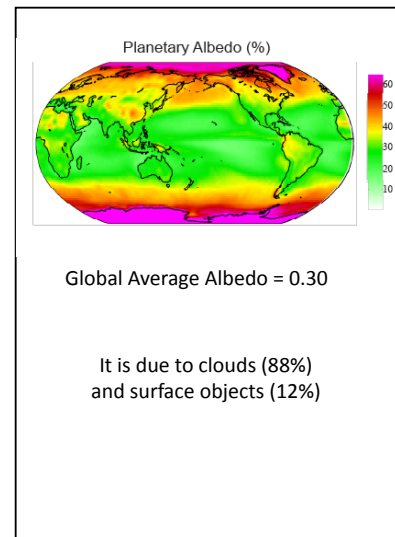

# Contributions of surface and atmosphere to the planetary albedo

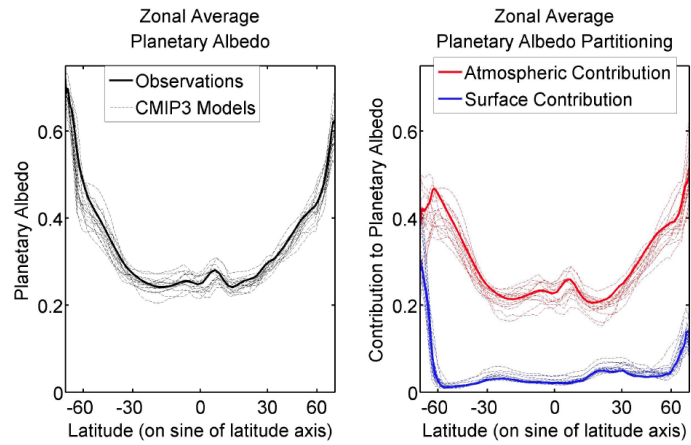

(Zonal Average = average in the east-west direction)

## Annual Radiation Balance

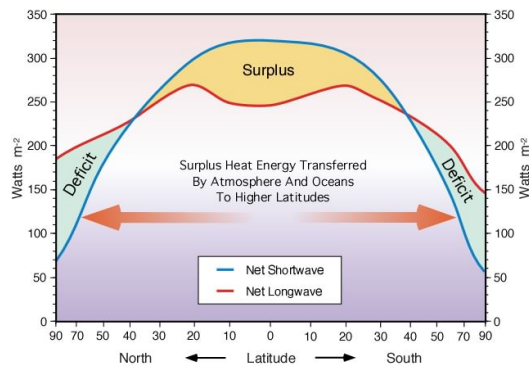

The meridional gradient in Absorbed Solar Radiation drives circulation.

## Northward Energy Transport

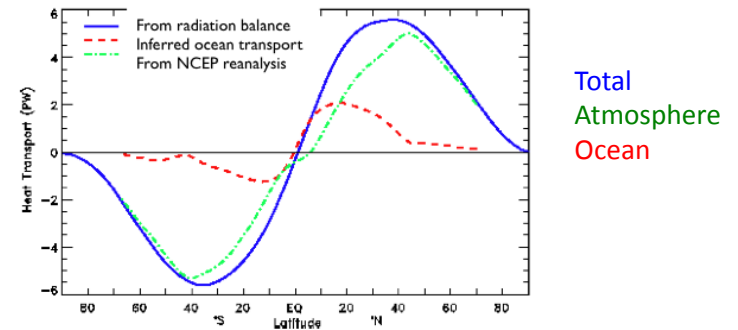

Ocean does most of the transport in the deep tropics (15°S-15°N)

Atmosphere does most of the transport poleward of 30°N,S

## What does the energy transport?

- Circulation move excess heat and moisture from tropics to the poles
  - Advection of warm/cold air by midlatitude storms accounts for ~40%
  - Net evaporation in tropics -> net condensation in polar regions accounts for ~40%
  - Ocean currents (~20%)

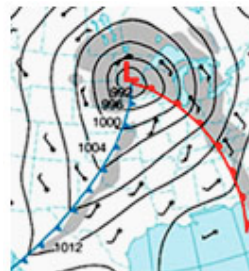
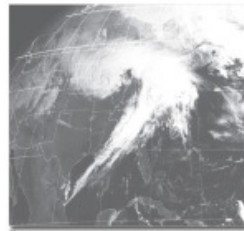

## Orbital Variations and Insolation

### Obliquity or Tilt

- Tilt angle is presently 23.44°
- Tilt is the main reason why we have large seasonal cycles in mid-latitudes and polar regions
  - More tilt, more extremes in seasonal cycle
  - No tilt, no seasons

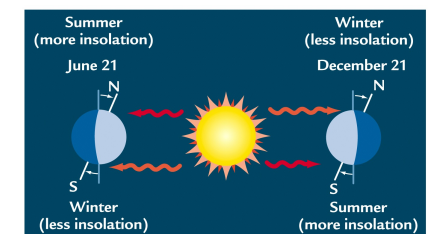
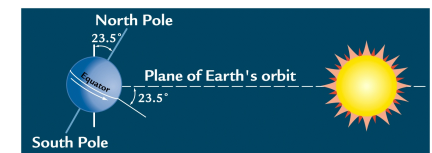

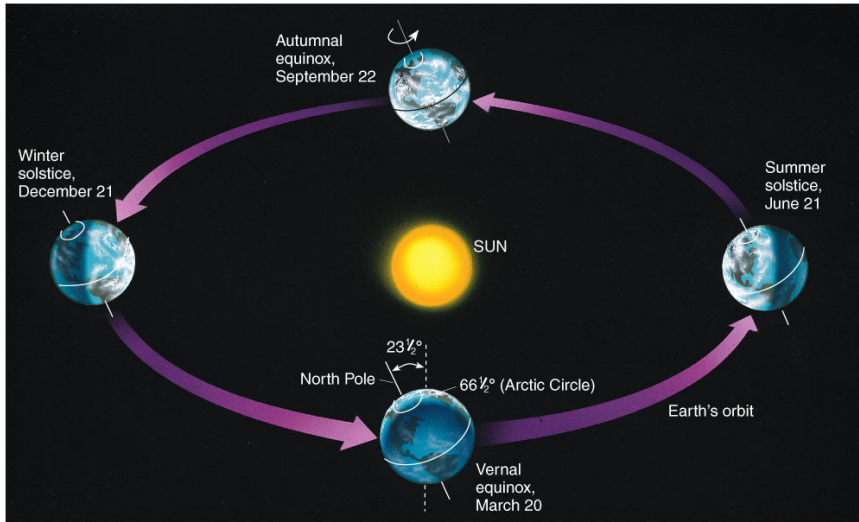

© 2007 Thomson Higher Education

Fig. 3-3, p. 57

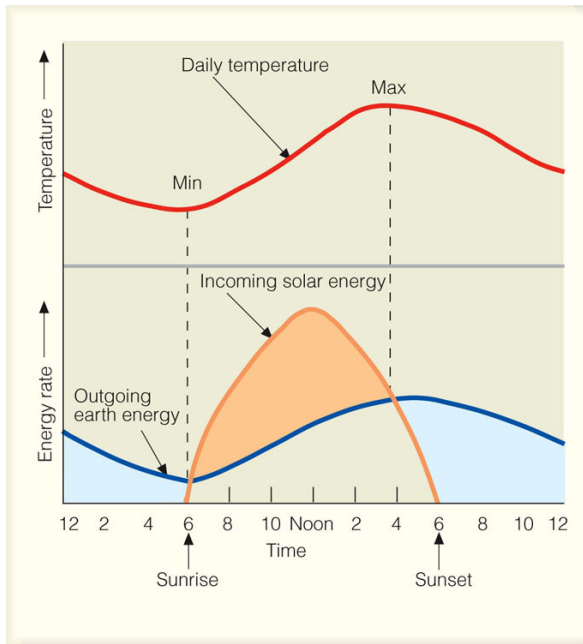
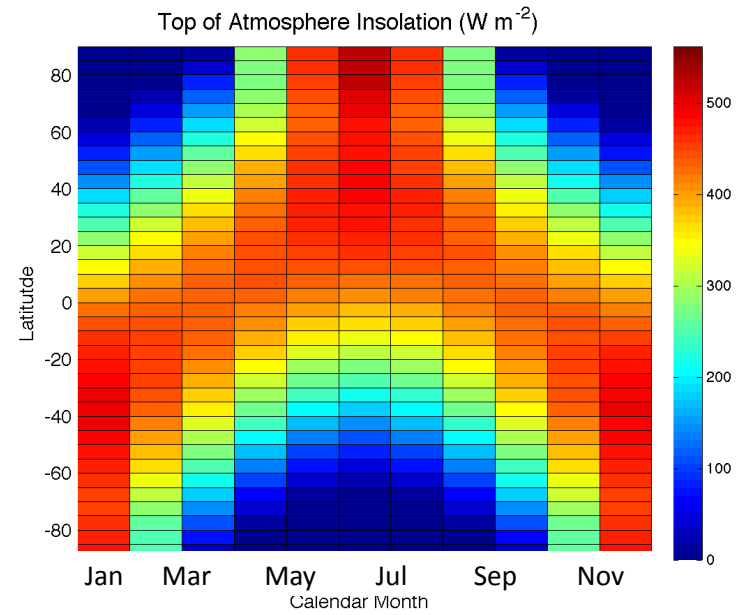

© 2007 Thomson Higher Education

Fig. 3-13, p. 65

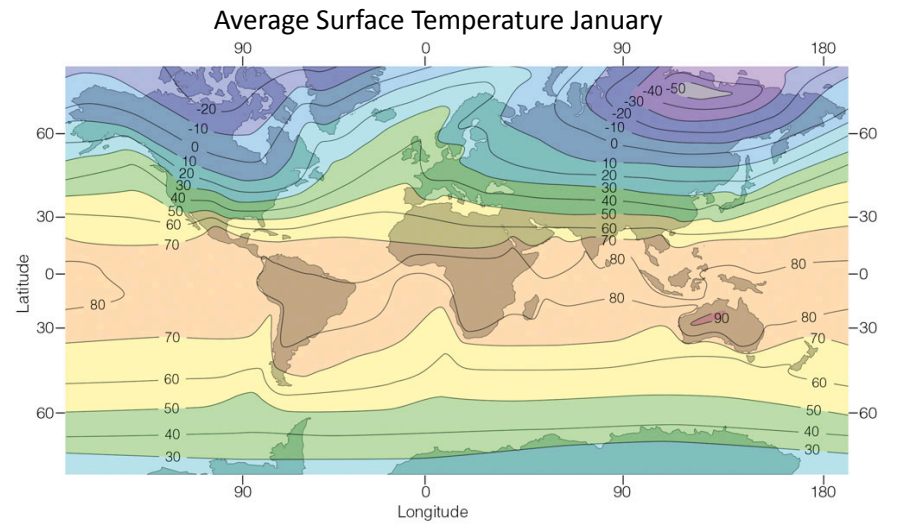

© 2007 Thomson Higher Education

Fig. 3-20, p. 72

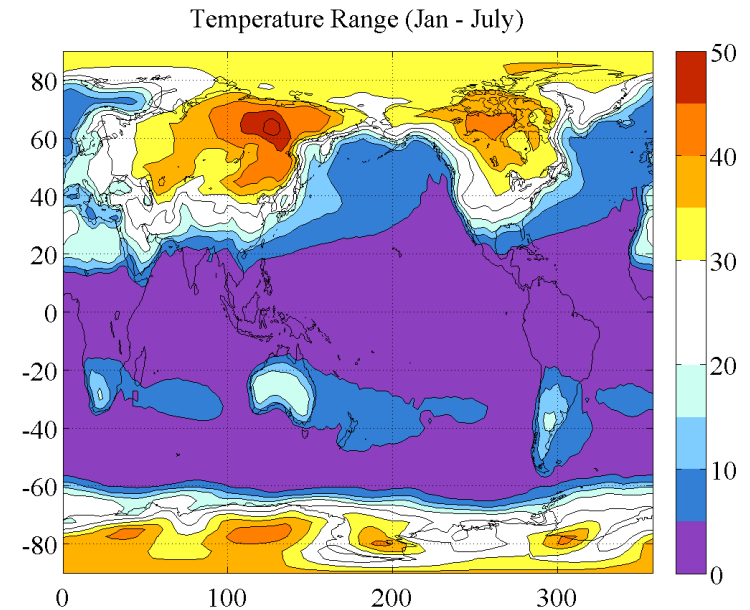
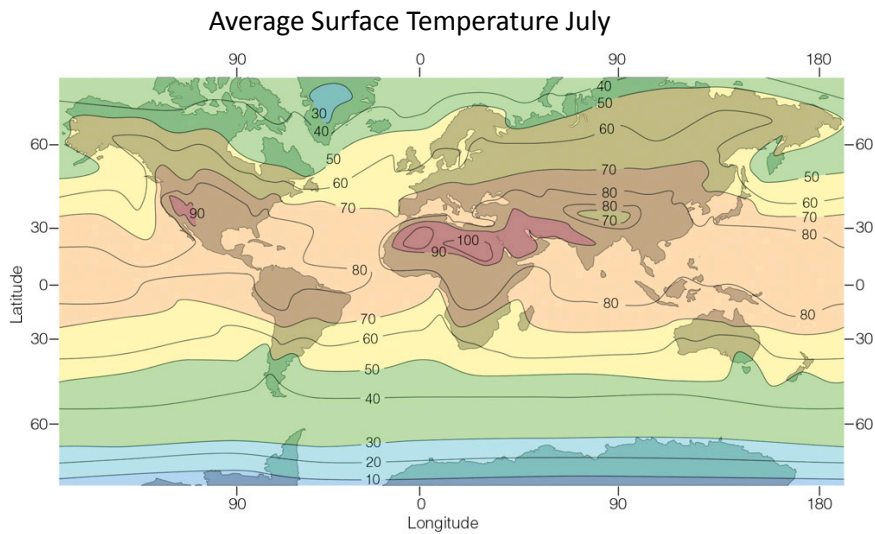
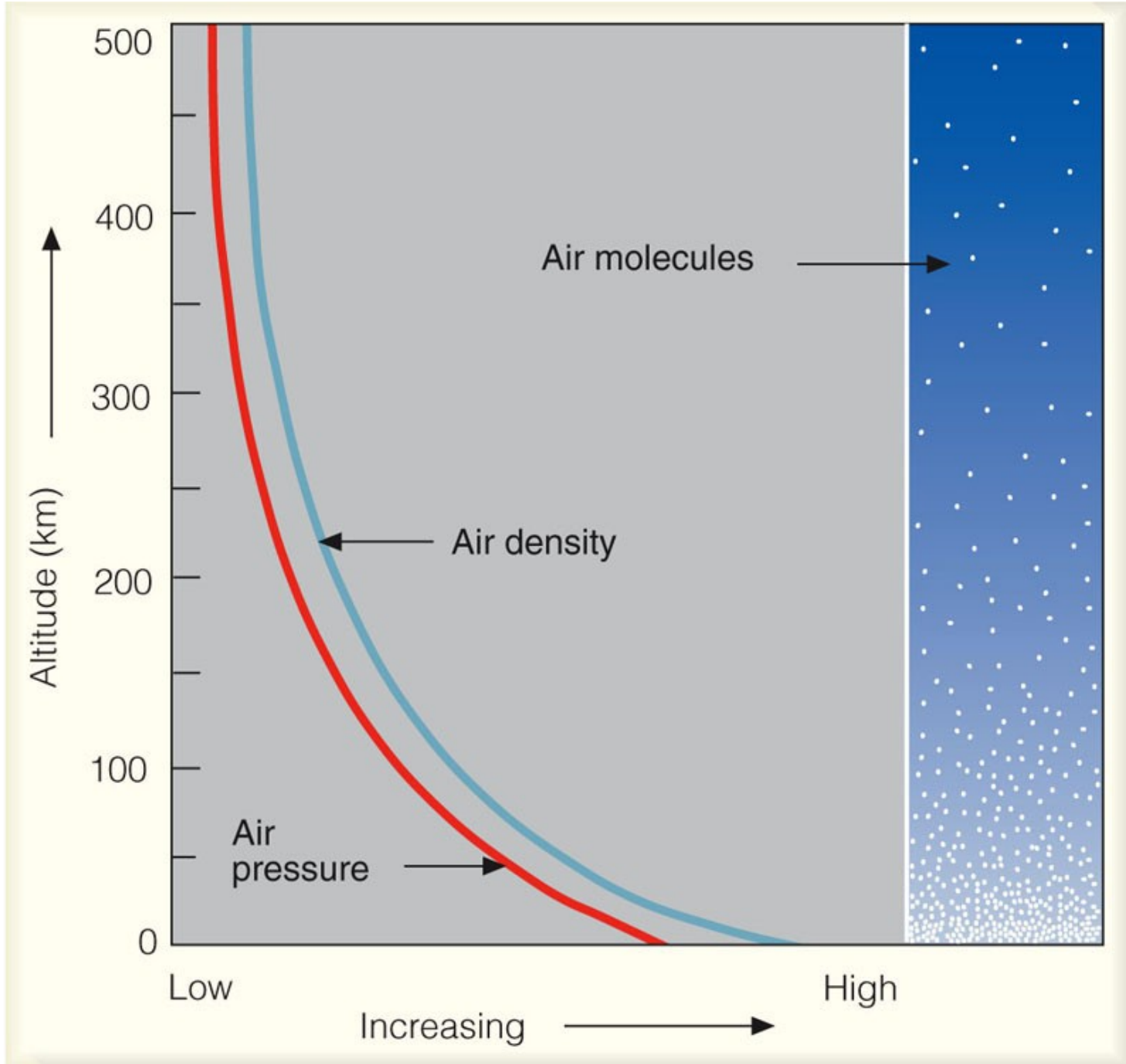

Fig. 3-21, p. 72

## Periodic Temperature Cycles

- The Annual Average Equator-to-Pole Temperature difference
  - Due mainly to differences in Solar energy absorbed at the surface, which is mainly due to
    - Differences in *intensity* (energy per unit area) of insolation at the top of the atmosphere (2/3)
    - Distribution of clouds vs. latitude (more in midlats and polar regions, less in tropics) that reflect sunlight (1/3)
- The Diurnal (day-night) Cycle of Temperature
- The Annual Cycle of Temperature
  - Due to Earth's "tilt" (rotational axis not perpendicular to plane of the Earth-Sun orbit)
- Maritime vs. Continental
  - Mainly due to different amount of mass that is heated
- Odds and Ends
- Summary of Temperature Controls



# Vertical Pressure Gradients and Circulation

- *Vertical* pressure differences (gradients) in the vertical are nearly balanced by gravity
  - Hence, vertical motions are weak
  - Pressure decreases with increasing height

Troposphere  
(where all the weather is)

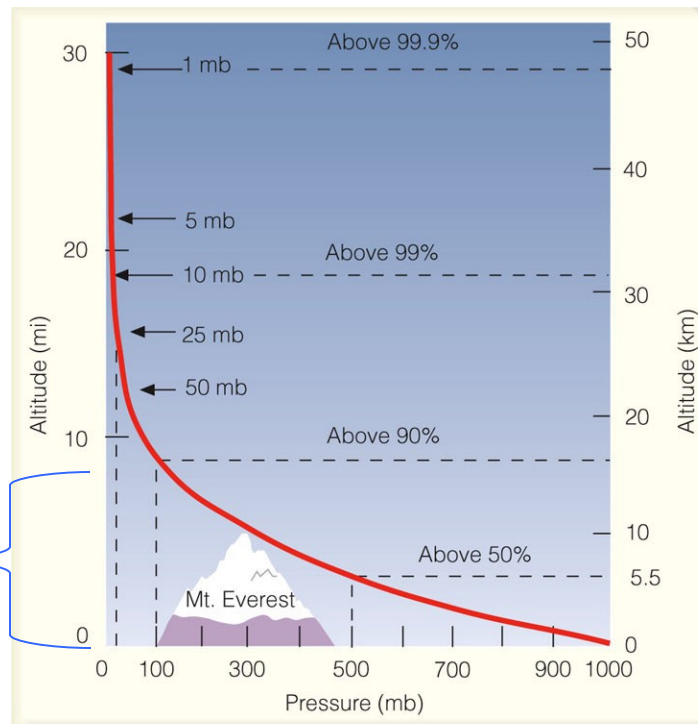

# Vertical Pressure Gradients and Circulation

- *Vertical* pressure differences (gradients) in the vertical are nearly balanced by gravity
- This balance is called the *hydrostatic balance*

**Vertical**

$$\frac{1}{\rho} \frac{\Delta P}{\Delta z} = -g$$

Acceleration due to  
*vertical* pressure  
differences (gradients)

Acceleration due to  
gravity

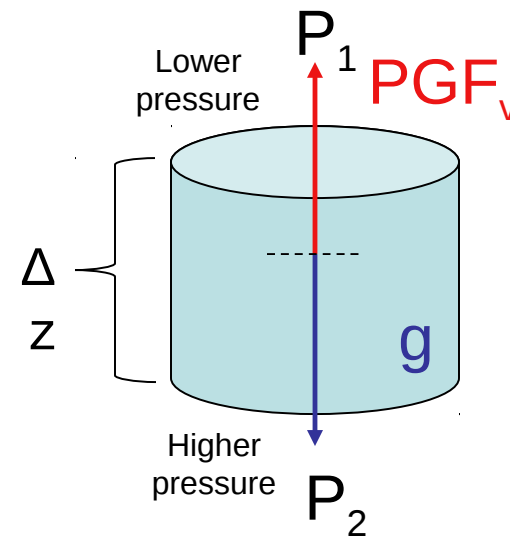

- It holds to within 0.01% in the atmosphere and ocean
- Hence, vertical motions are weak

# Horizontal Pressure Gradients and Circulation

- *Horizontal* pressure differences (gradients) are weak but *not* balanced by gravity

$$\frac{1}{\rho} \frac{\Delta P}{\Delta x} = ?$$

Acceleration due to  
*horizontal* pressure  
differences (gradients)

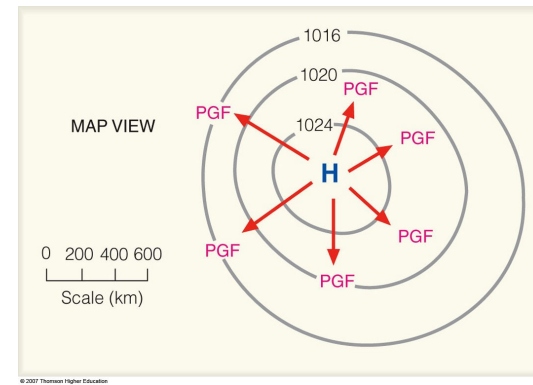
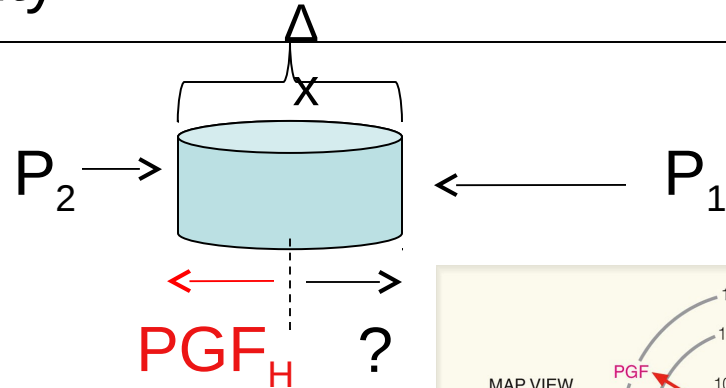

- Hence, horizontal pressure gradients drive winds
  - Air is forced (accelerated) from high towards low pressure
- The larger the pressure difference, the greater the acceleration
- E.g., sea breeze, wind gust, etc.

# Sea Breeze driven by horizontal pressure gradients

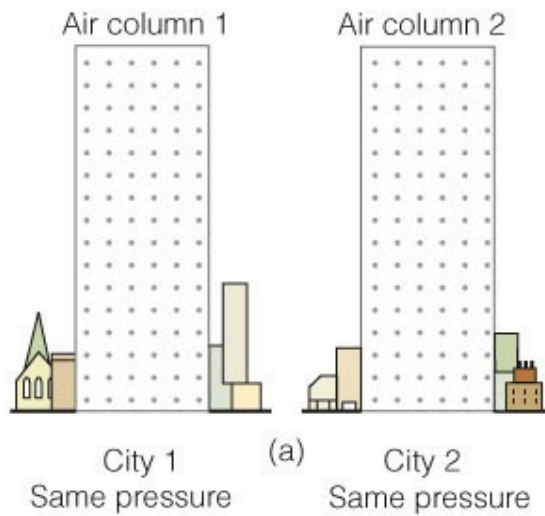

# Sea Breeze driven by horizontal pressure gradients

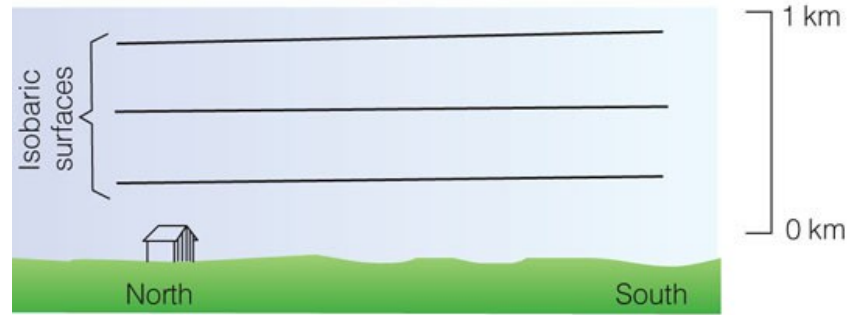

(a)

# Sea Breeze driven by horizontal pressure gradients

## Sea Breeze

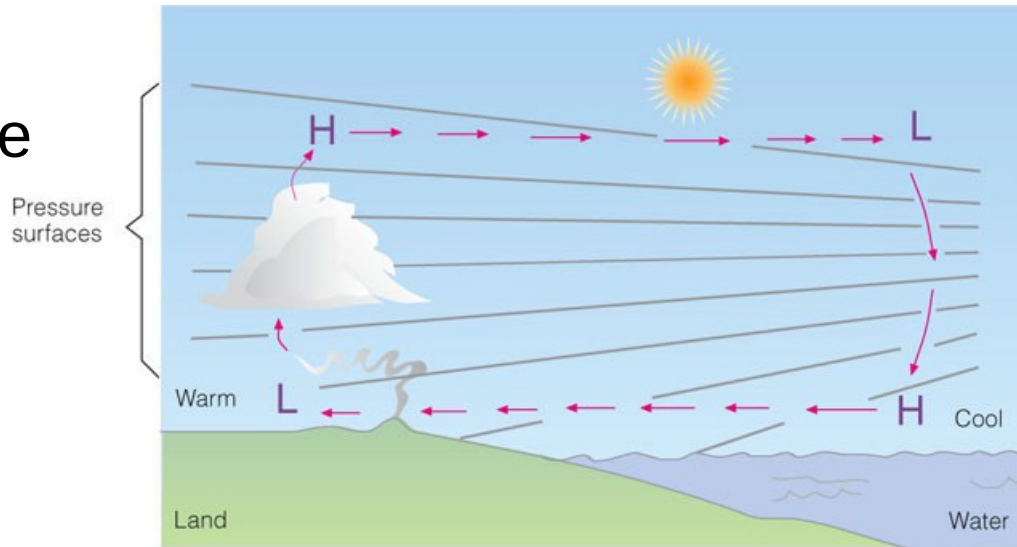

(a) Sea breeze

## Land Breeze

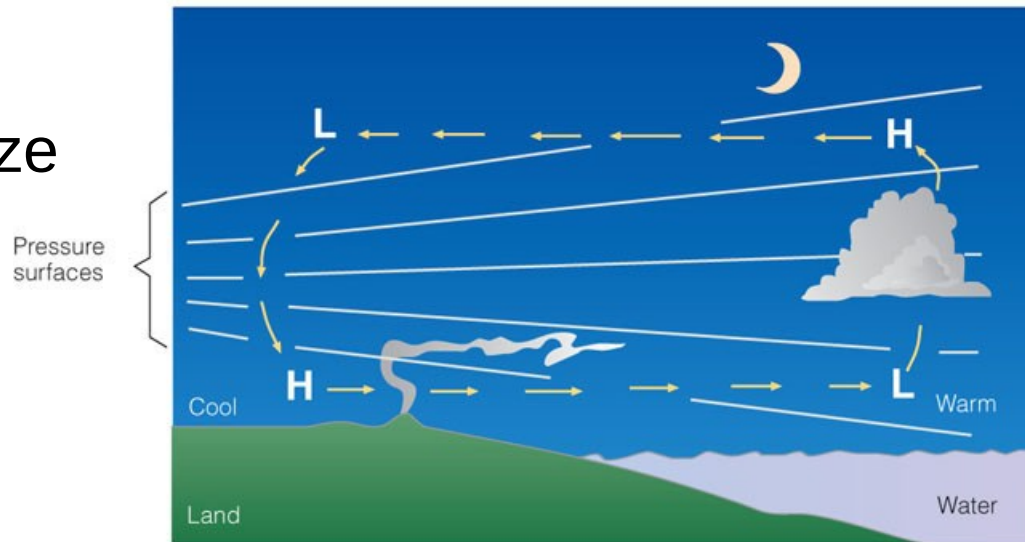

(b) Land breeze

# Horizontal Forces & Circulation

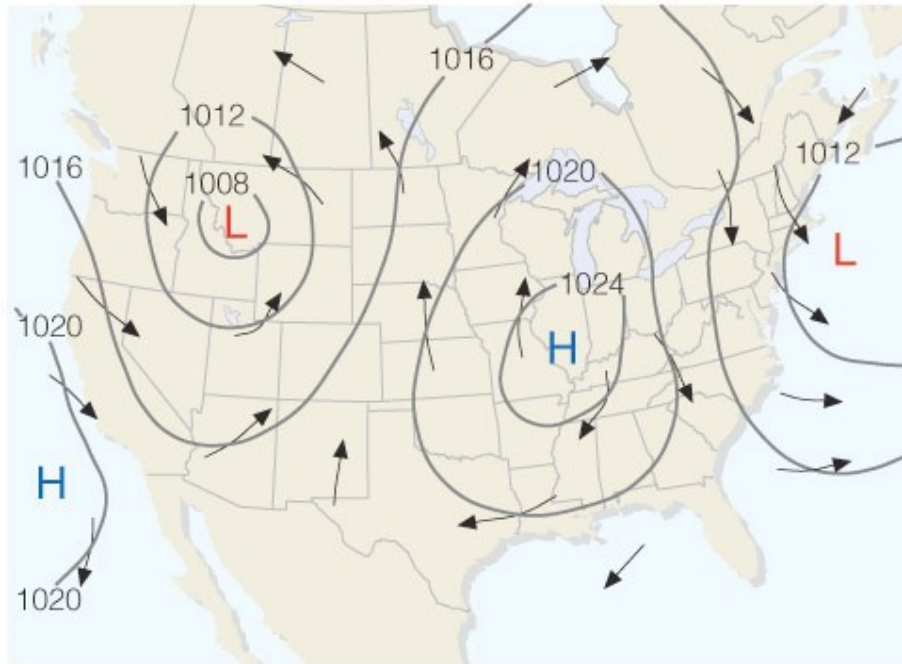

(a) Surface map

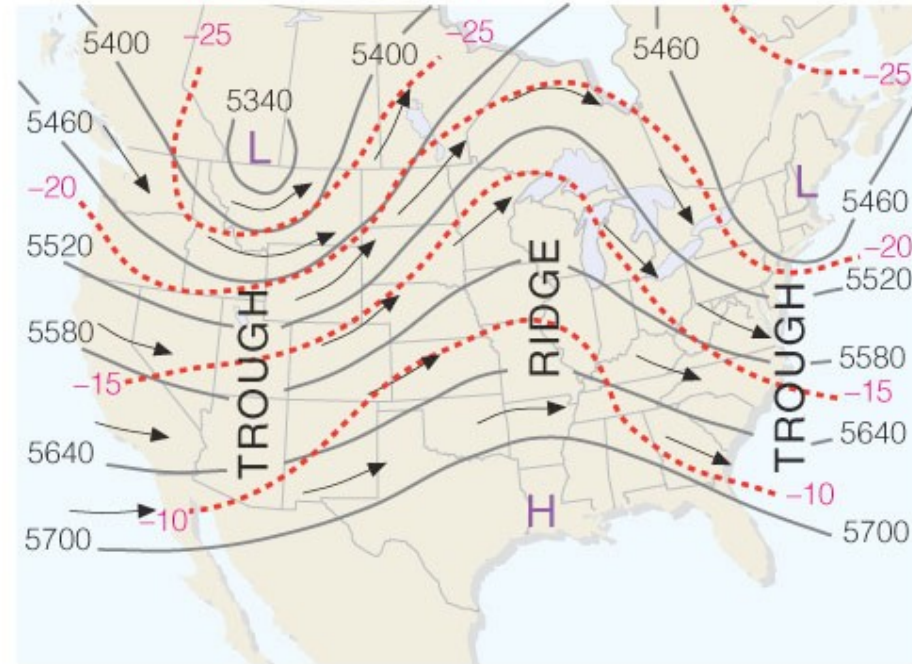

(b) 500-millibar map

- **On a weather map (or on any map of atmospheric flows last longer than a few hours)**
  - The wind is not accelerating in the direction of the horizontal pressure gradient! In fact, the wind blows along a line of constant pressure.
  - E.g., mid-latitude cyclones, jet stream
- **Why?**

# Coriolis Effect

- If the *horizontal* pressure gradients last long enough (longer than several hours) or the air displacement is large enough (1000 of km) rotation of the earth greatly affects the motion
- In these cases, the air experiences the Coriolis Effect (or Force) which is a frame-of-reference effect: the combined effect of
  - Observers reference frame (on earth) is rotating
  - Gravity acting to keep air on the spherical Earth

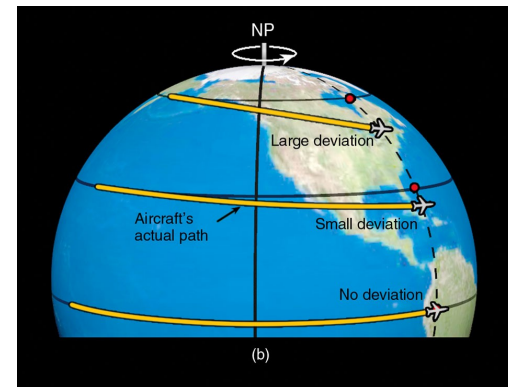
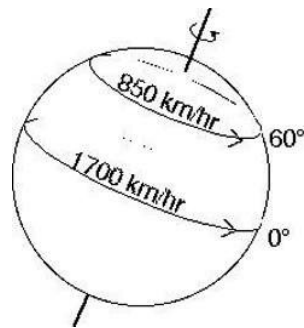

In the net, air moving in the northern hemisphere experiences an *apparent force* to the right of motion

# Coriolis Effect (“Force”)



# An imperfect analog to understanding frame of reference

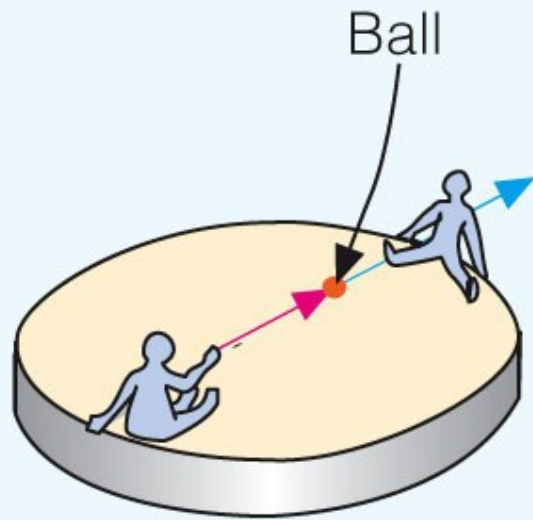

Platform A (nonrotating)

Apparent path as seen by observer on rotating platform

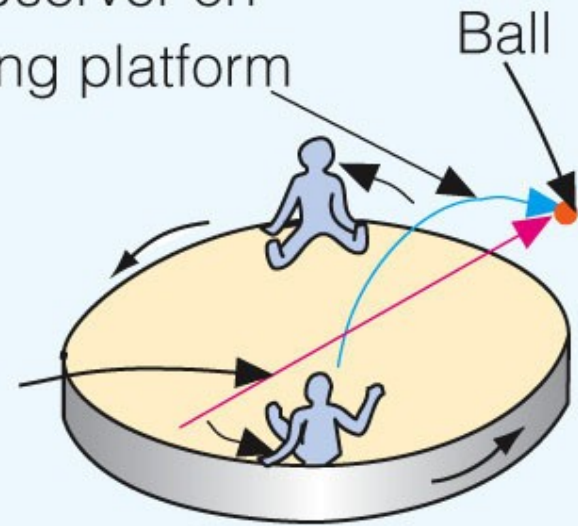

Actual path

Platform B (rotating)

The Coriolis Force (CF) depends on latitude and wind speed

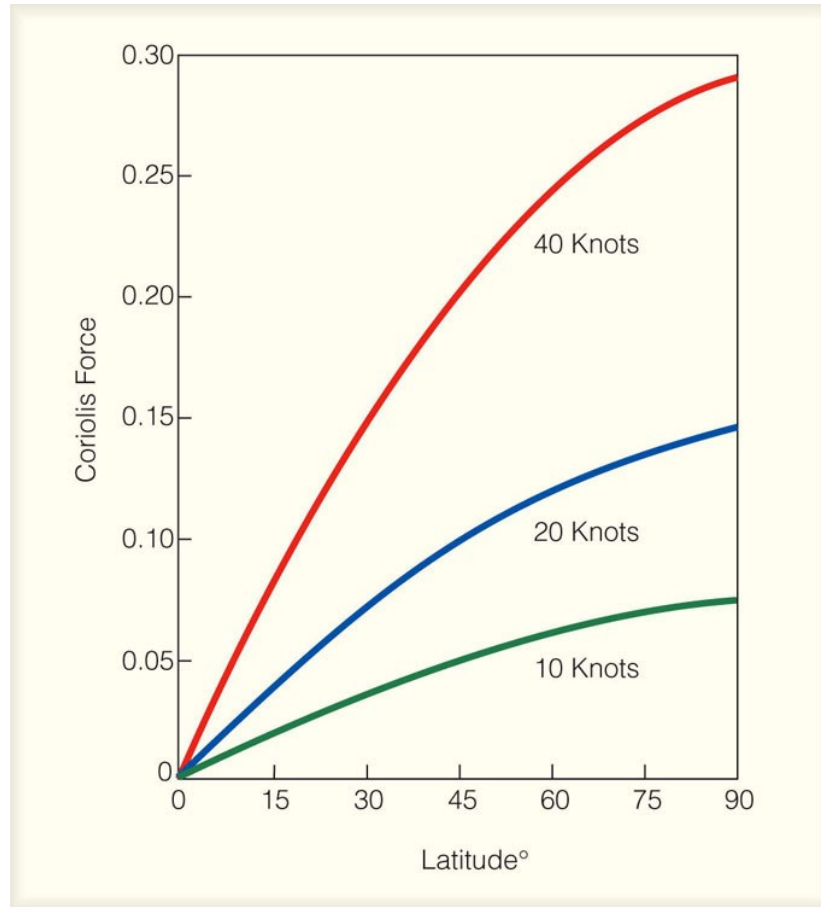

© 2007 Thomson Higher Education

$$CF = (2 \Omega \sin \phi) * V$$

where  $\phi$  is latitude  
and  $\Omega$  is a constant  
and  $V$  is the speed of  
the air relative to the  
rotating Earth (ie, as  
seen by an observer  
rotating with the earth)

Stronger wind => Stronger CF  
Higher latitude => Stronger CF

When the horizontal pressure gradient balances the Coriolis Force the air is said to be in *geostrophic balance*

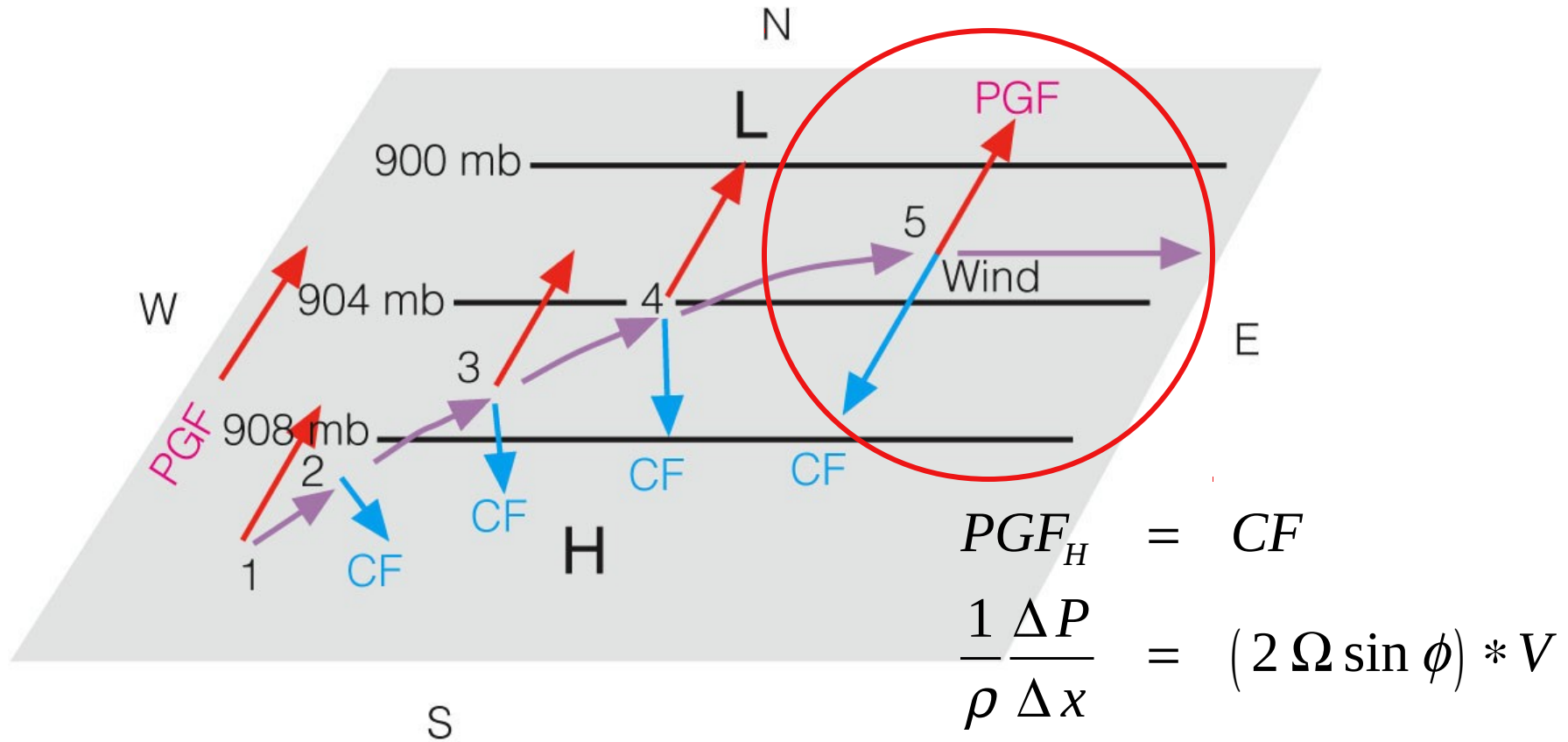

In geostrophic balance, the wind blows *along* a line of constant pressure (an isobar)

# Geostrophic Wind

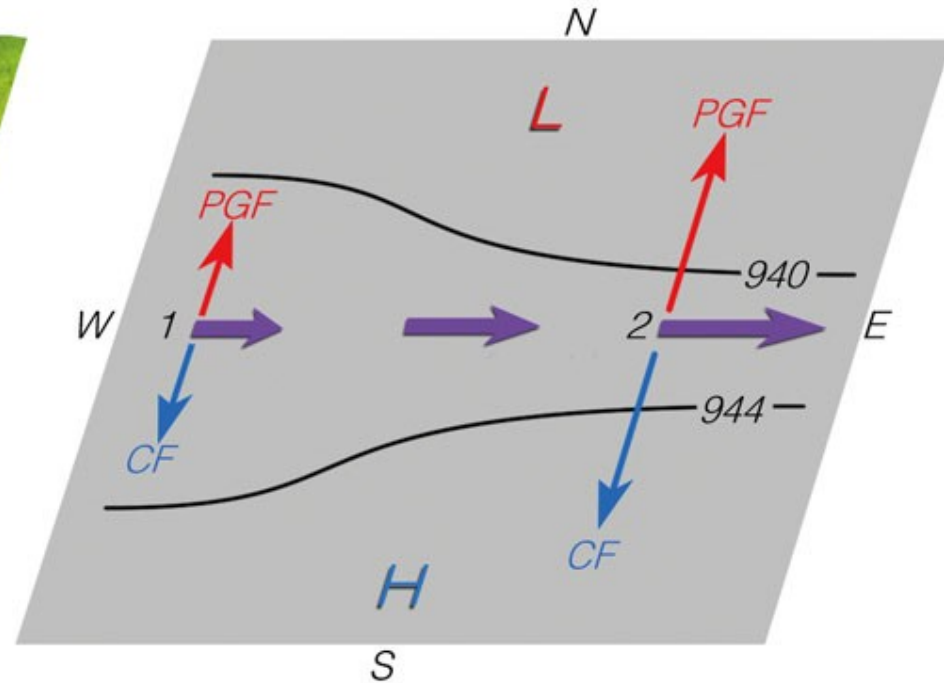
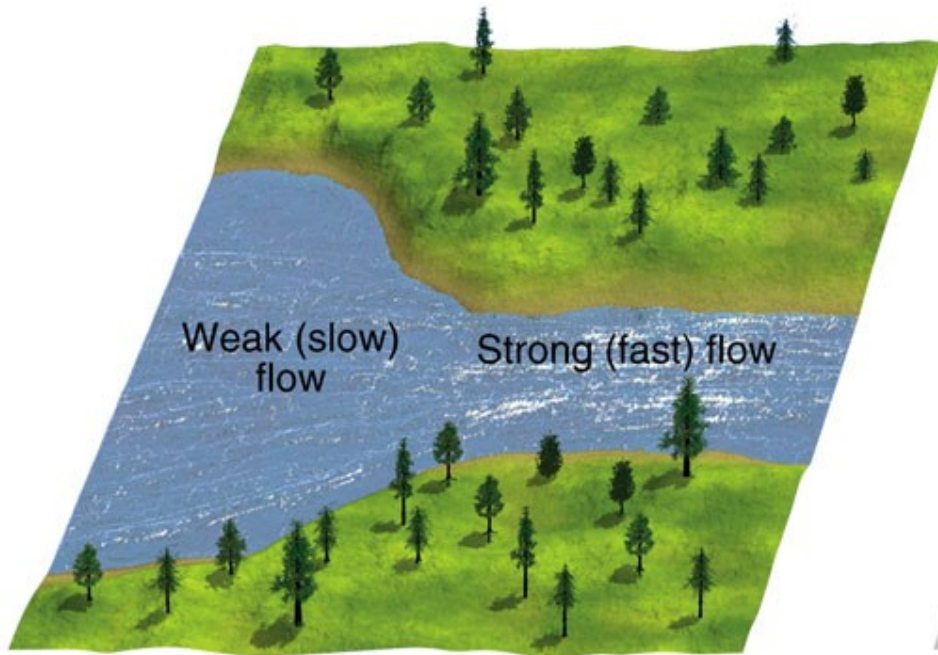

© 2007 Thomson Higher Education

The stronger the  $PGF_v$ , the stronger the CF  
(hence, the stronger the wind)

# The Horizontal Wind is nearly Geostrophic

Geostrophic

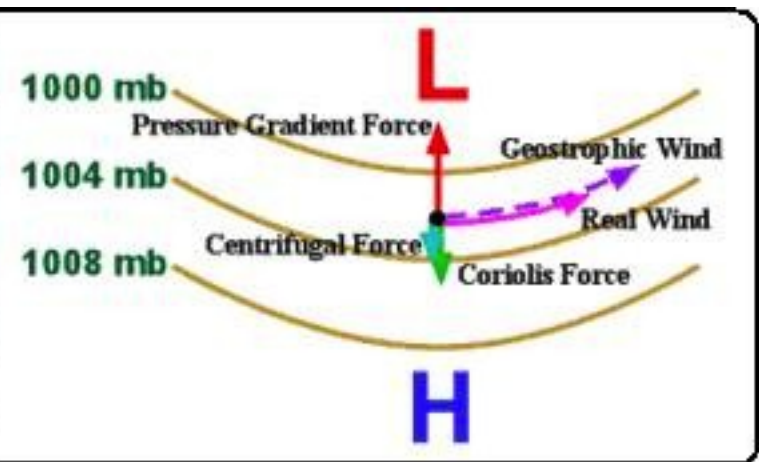
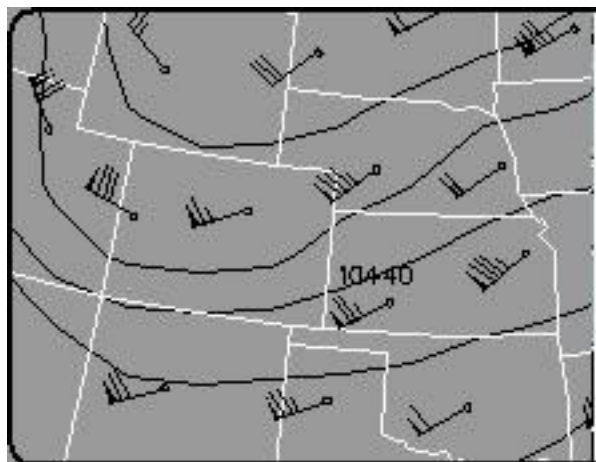
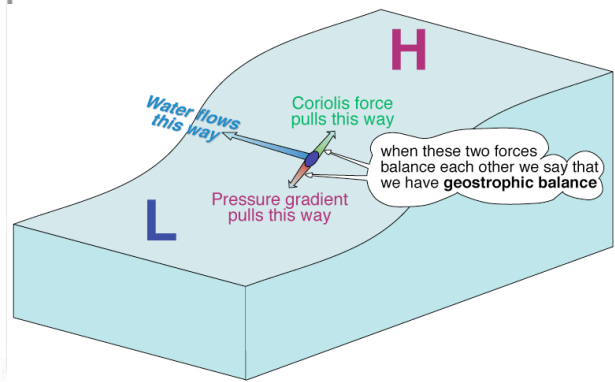
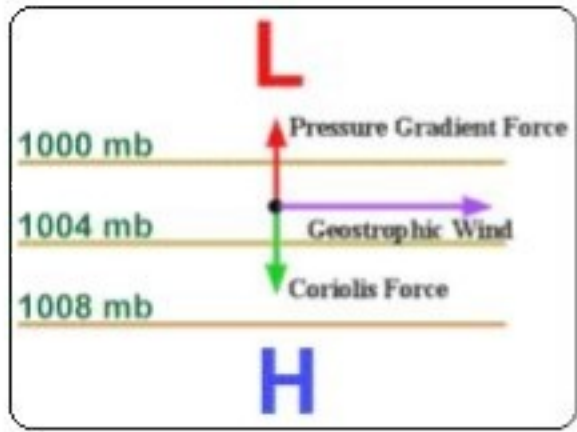
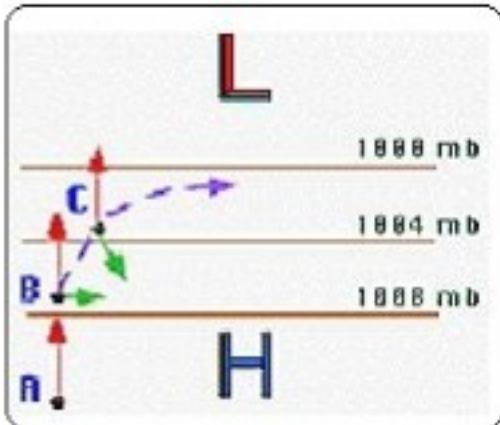

**Nearly Geostrophic Flow**  
(it is curved)

*Northern Hemisphere*

# The Horizontal Wind is nearly Geostrophic

CYCLONIC FLOW

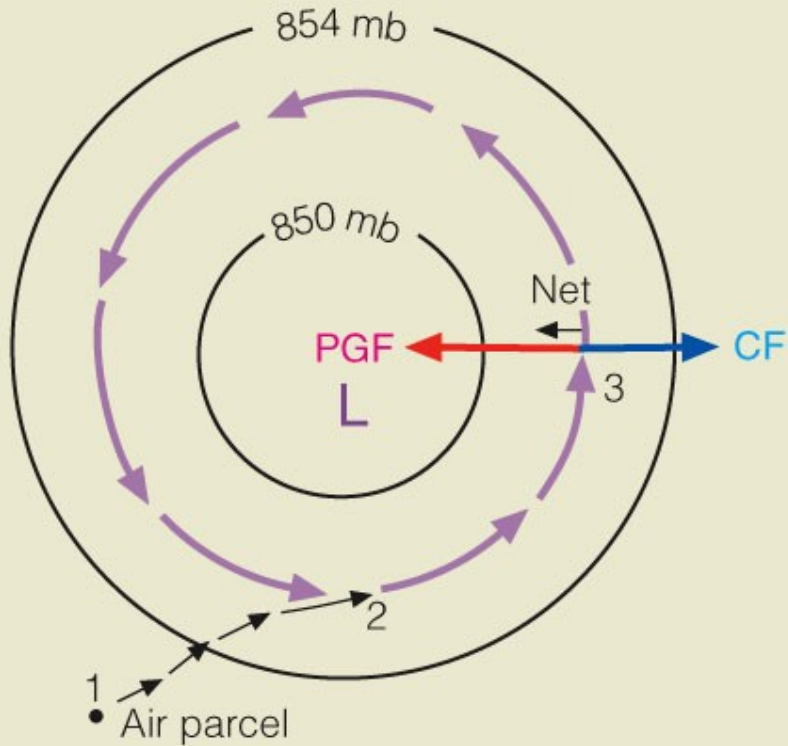

(a) Low pressure area (cyclone) aloft

ANTICYCLONIC FLOW

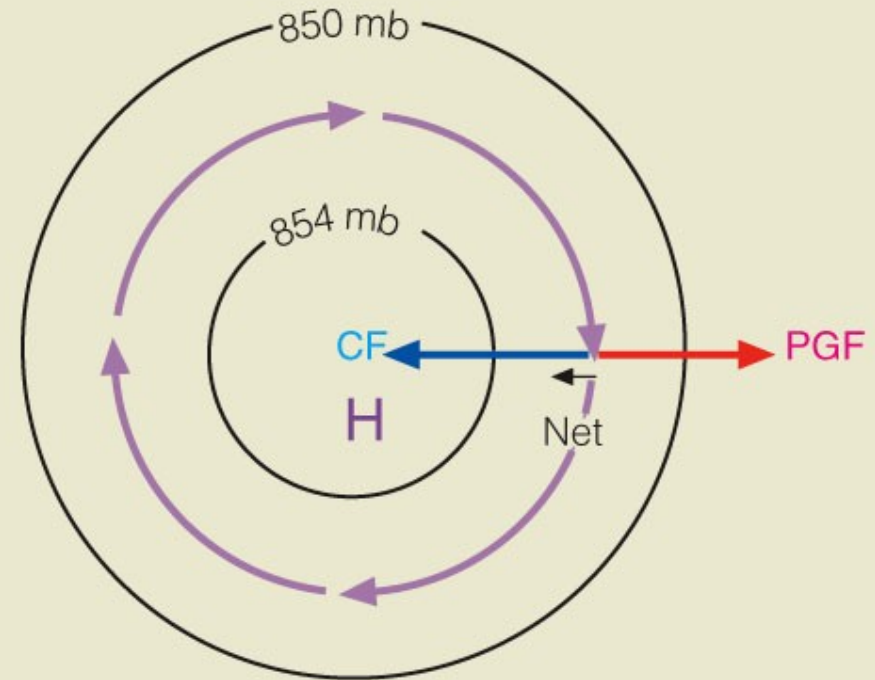

(b) High pressure area (anticyclone) aloft

# The flow at ~ 5.6km is nearly Geostrophic

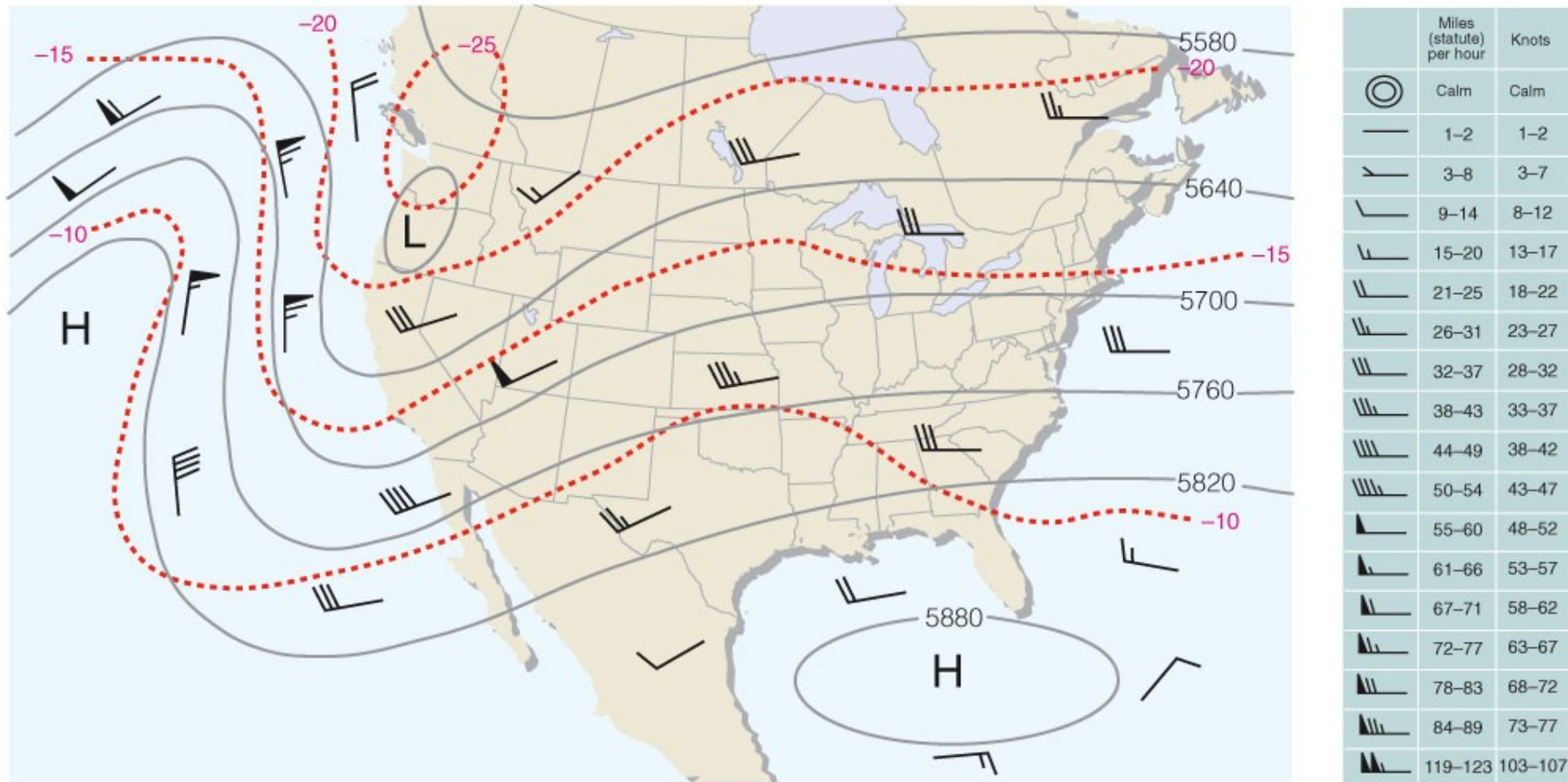

© 2007 Thomson Higher Education

- **The flow is nearly perfect *geostrophic balance***
  - ◇ the *horizontal* pressure gradients are balanced by Coriolis Force, and the wind blows along a line of *constant* pressure
- **E.g., day to day weather, mid-latitude storms, jet stream, monthly flows, seasonal flows ..**

# The Horizontal Wind is nearly Geostrophic

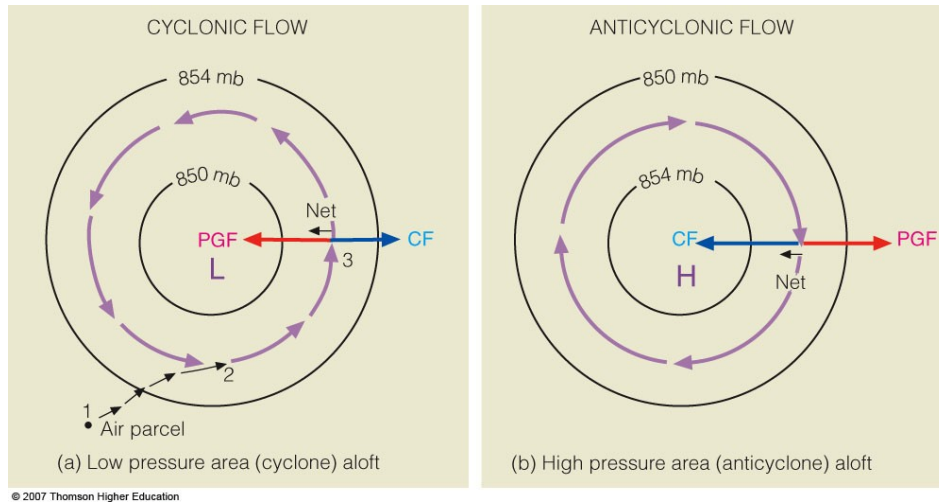

Northern Hemisphere

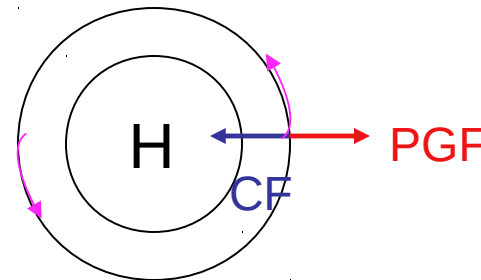
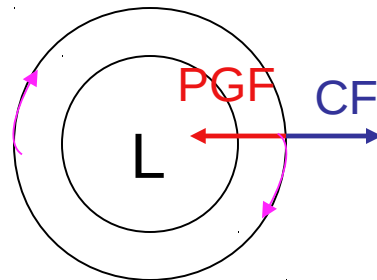

Southern Hemisphere

The CF acts to accelerate the air to the left of the motion in the Southern Hemisphere

# Sea Level Pressure

To determine horizontal pressure gradients that drive winds, we need to compare pressures at the same elevation

Surface Pressure

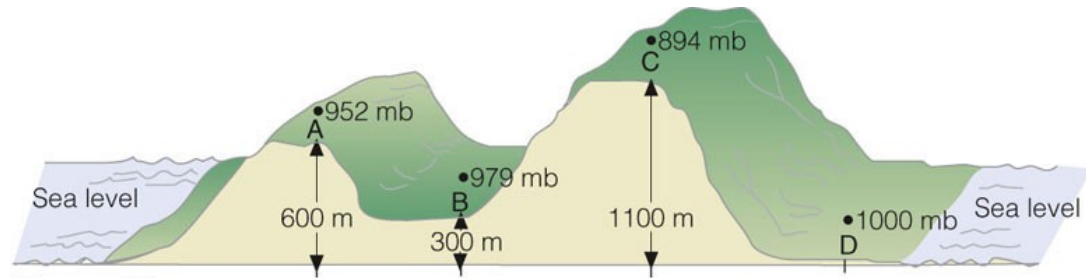

# Horizontal Forces & Circulation

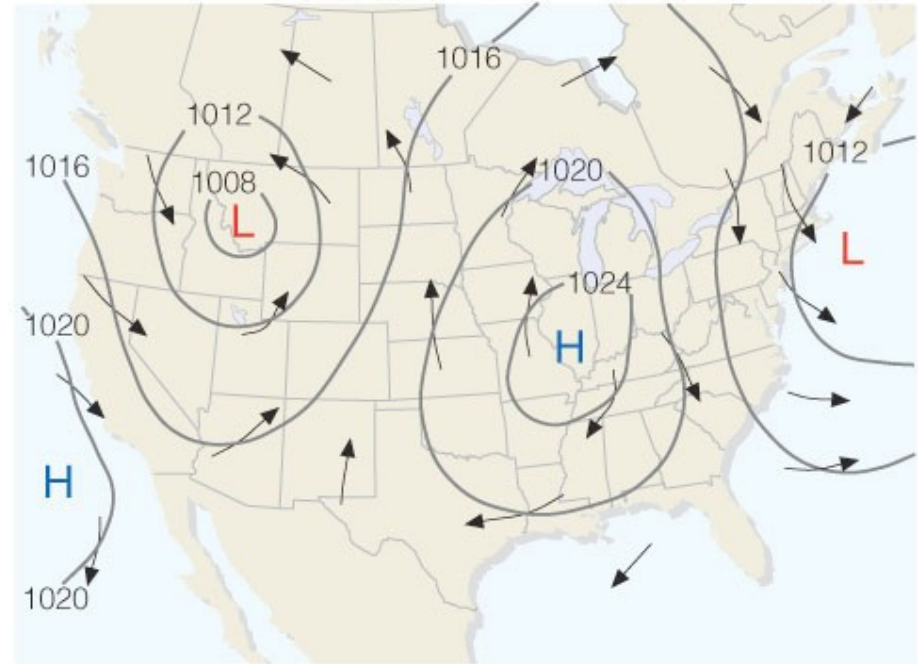
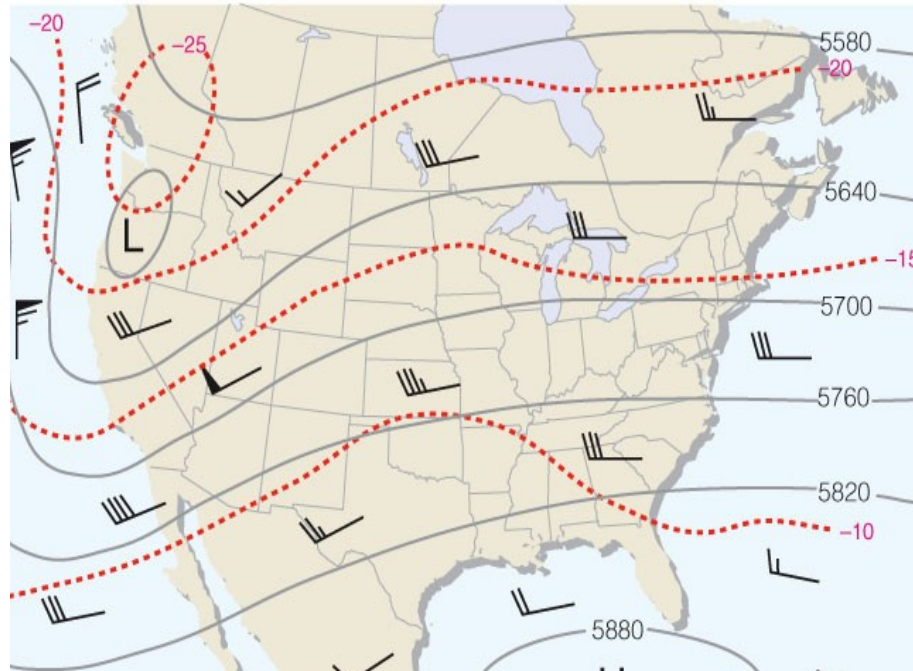

(a) Surface map

- Aloft, the flow is nearly in perfect geostrophic balance (PGF balanced by CF, so the flow is along an isobar (line of constant pressure))
- What about the flow near the surface? Is it in geostrophic balance?

# Near Surface Winds

They feel  $PGF_H$ ,  $CF$  and friction from the rough surface

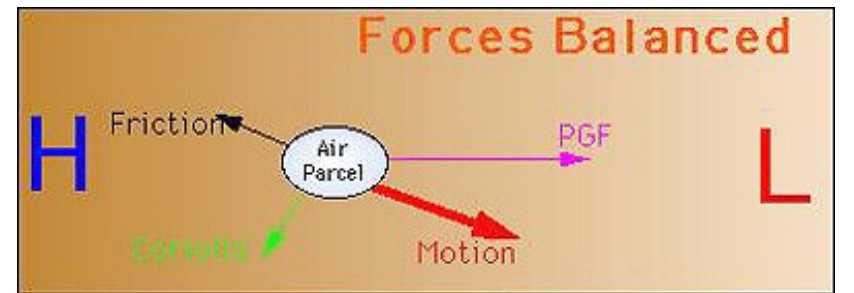
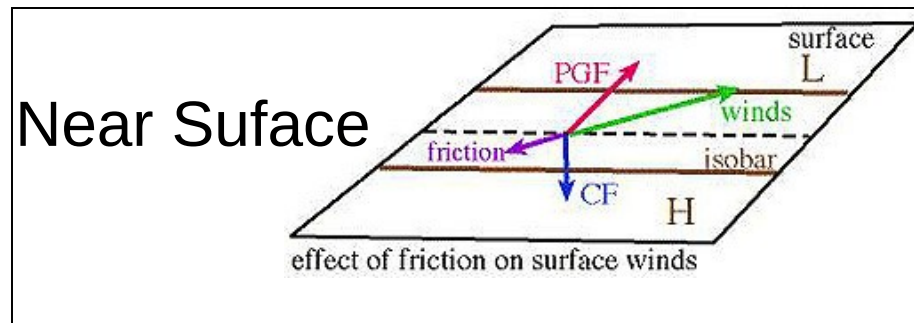
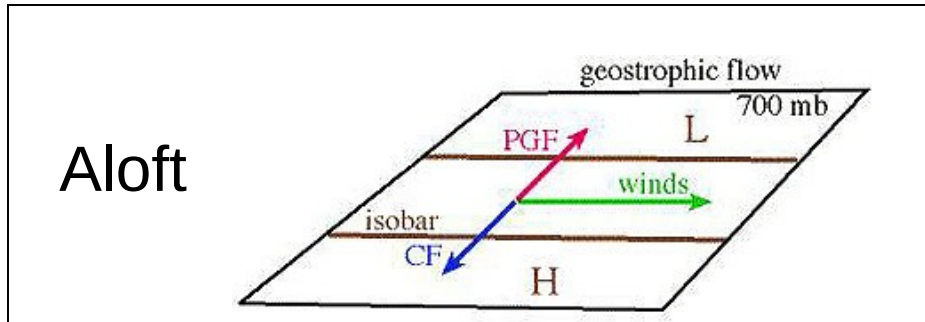

Averaged over many hours, the net force balance is zero and so at the surface there is a small component to the wind that blows toward the low pressure.

Hence, air tends to flow out of a surface high, causing sinking motion and convergence aloft (fair weather)

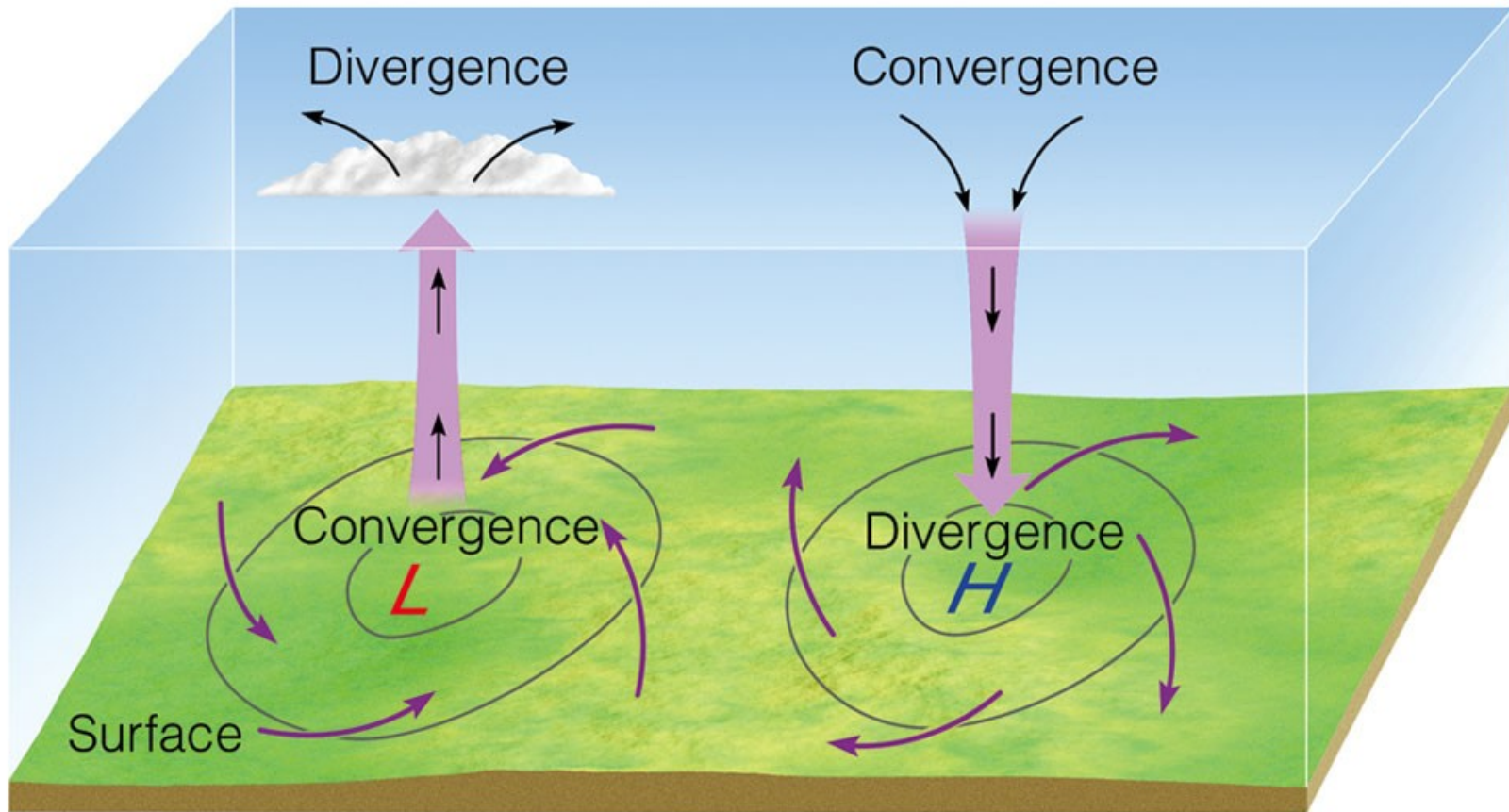

© 2007 Thomson Higher Education

Conversely, air tends to flow into of a surface low, causing convergence and rising motions aloft (cloudy)

# A very good analog for the Surface Low

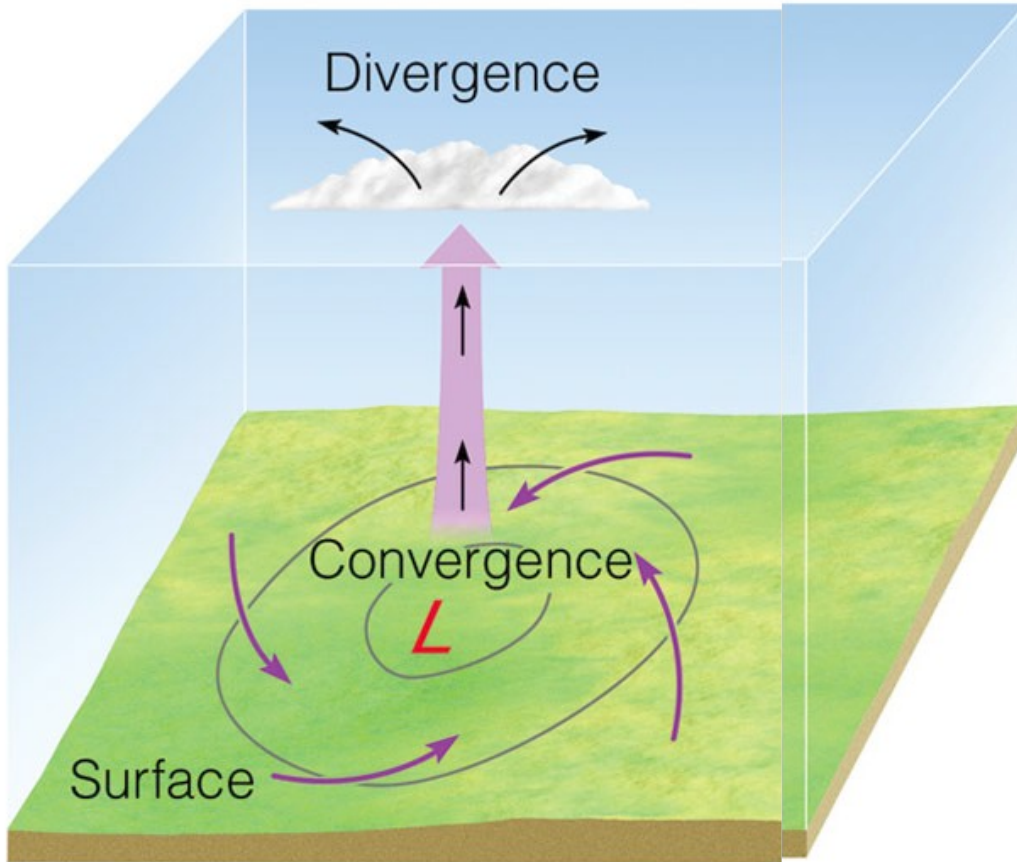

# Jets

- The air column in the tropics is warmer than that at the poles. Hence, the density is less in the tropics so going up into the atmosphere, pressure drops more slowly in the tropics than in the polar regions

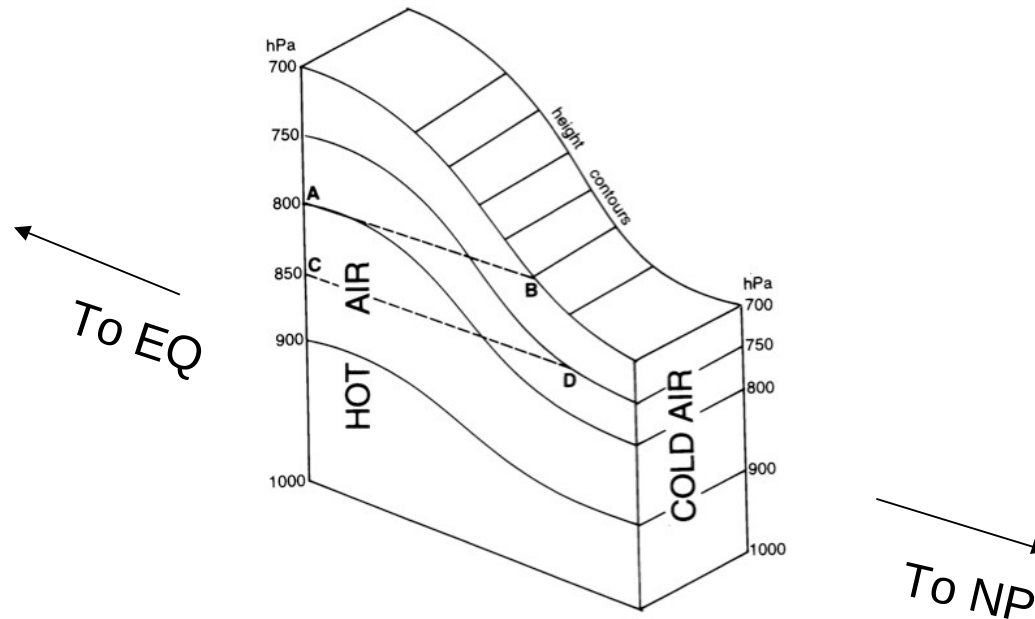

- Hence, a poleward pressure gradient develops as you go up from the surface

# Jets

- A poleward horizontal pressure gradient develops and strengthens as you go up
- Air density decreases too, so the  $\text{PGF}_H$  becomes huge. Hence, the winds increase as you go up.

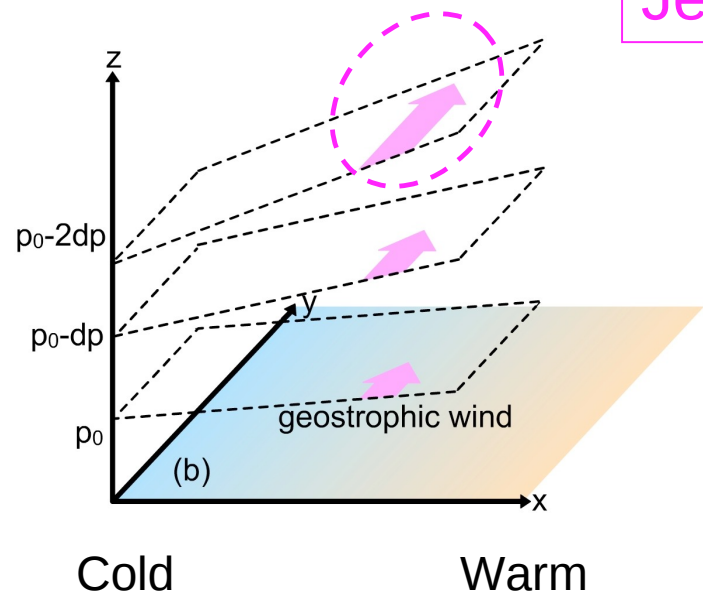
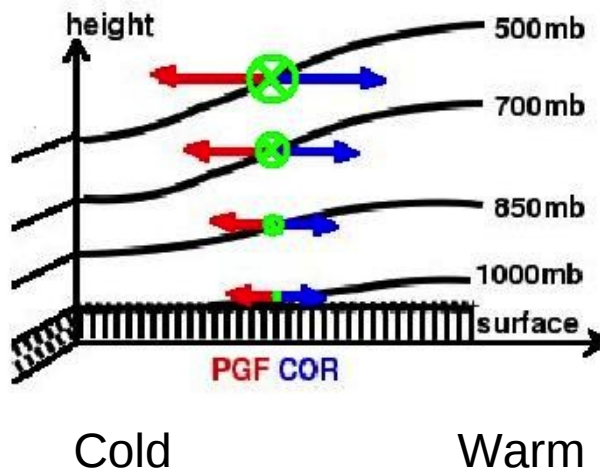

# Climatological Winds at 200mb up

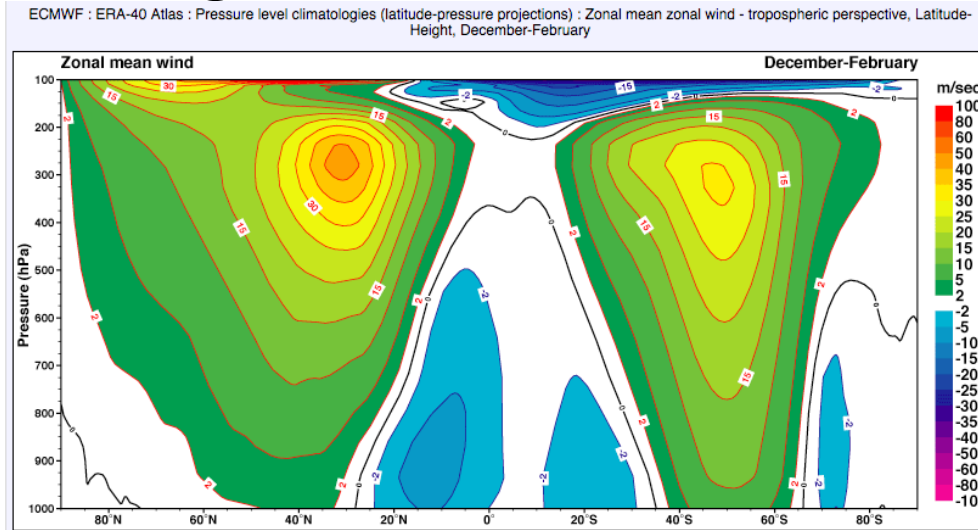

Monthly Mean 200-hPa Wind (m/s): January  
Climatology: 1979-1995

Monthly Mean 200-hPa Wind (m/s): July  
Climatology: 1979-1995

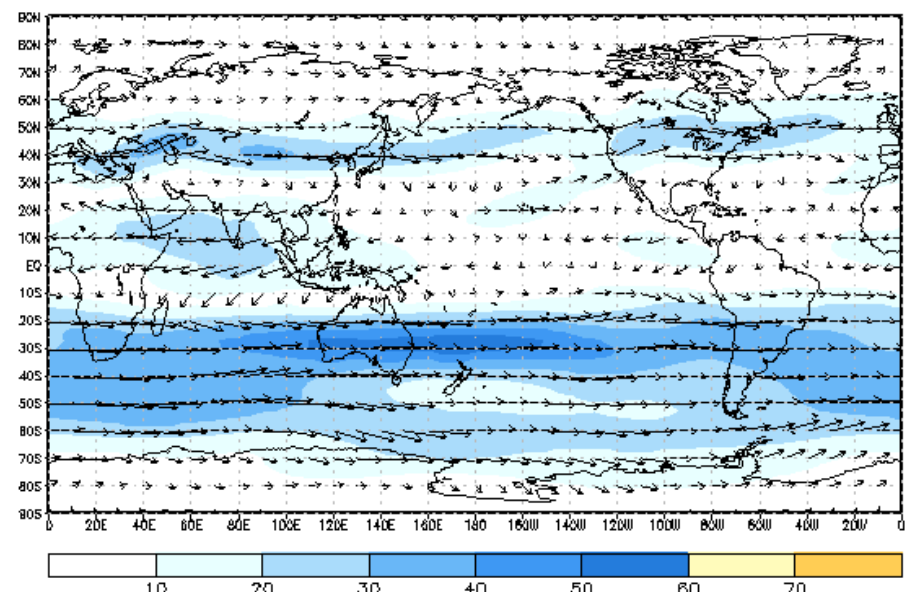
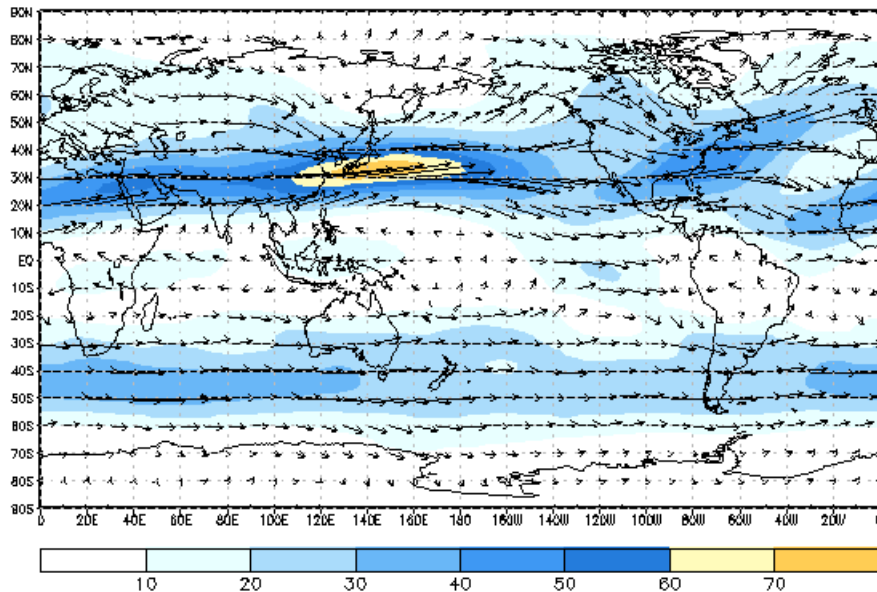

Movie

<http://www.cpc.ncep.noaa.gov/products/precip/CWlink/climatology/200wind/200windloop.gif>



# Mapping Pressure Gradients

- Horizontal pressure gradients that cause acceleration must be measured along a plane of constant elevation
- Horizontal pressure gradients on a constant elevation are proportional to horizontal gradients of the *height* of a constant pressure surface

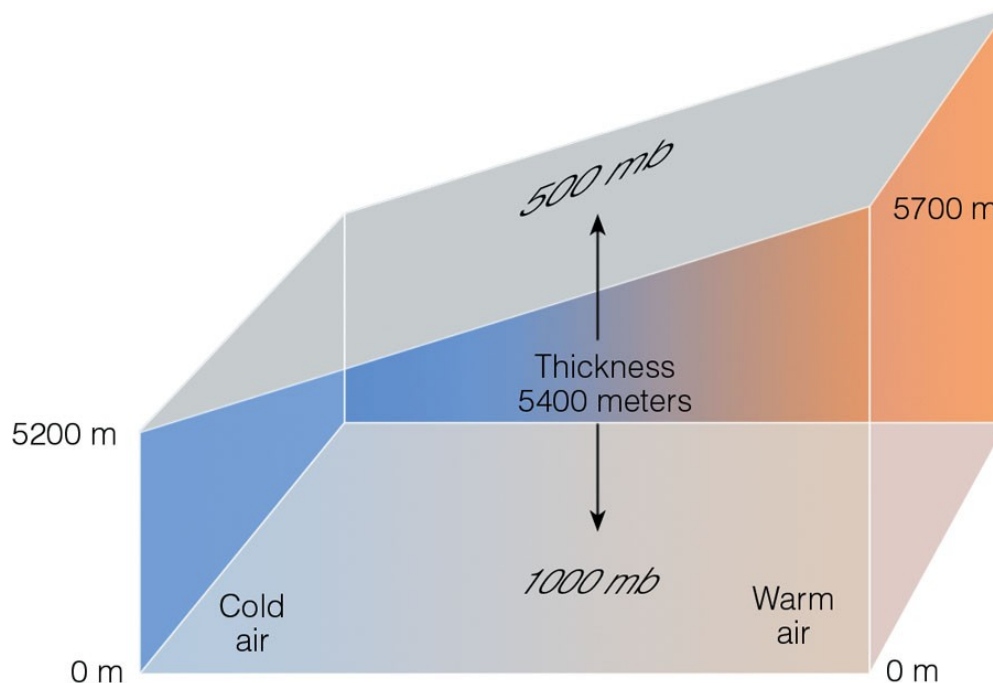

# Mapping Pressure Gradients

- Horizontal pressure gradients that cause acceleration must be measured along a plane of constant elevation
- Horizontal pressure gradients on a constant elevation are proportional to horizontal gradients of the *height* of a constant pressure surface

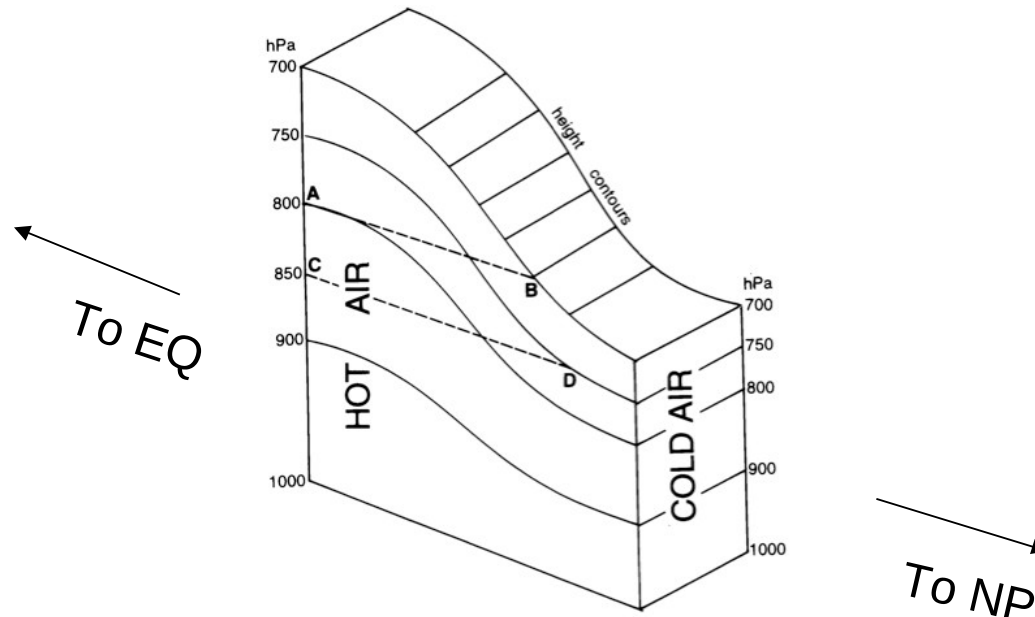

- Hence, we can infer/measure geostrophic wind using gradients in the height of a constant pressure surface

# Mapping Pressure Gradients

The height of the 500mb contour on this day

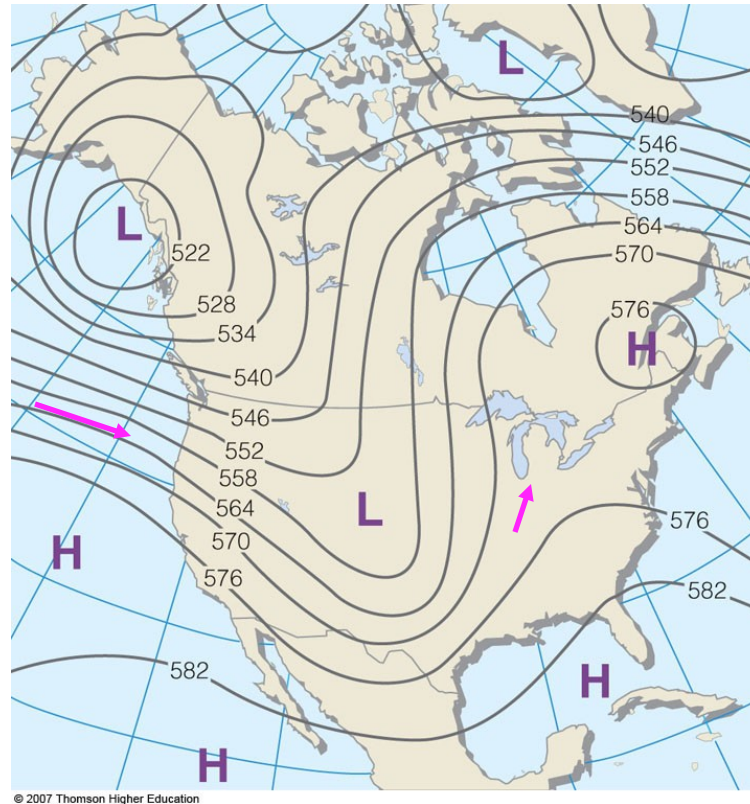

- Read this just like a pressure map on constant elevation:
  - flow is along a line of constant height
  - flow is strongest where the lines are closest together (stronger gradients = stronger CF ~ stronger wind)

# Balanced Flow (nearly Geostrophic)

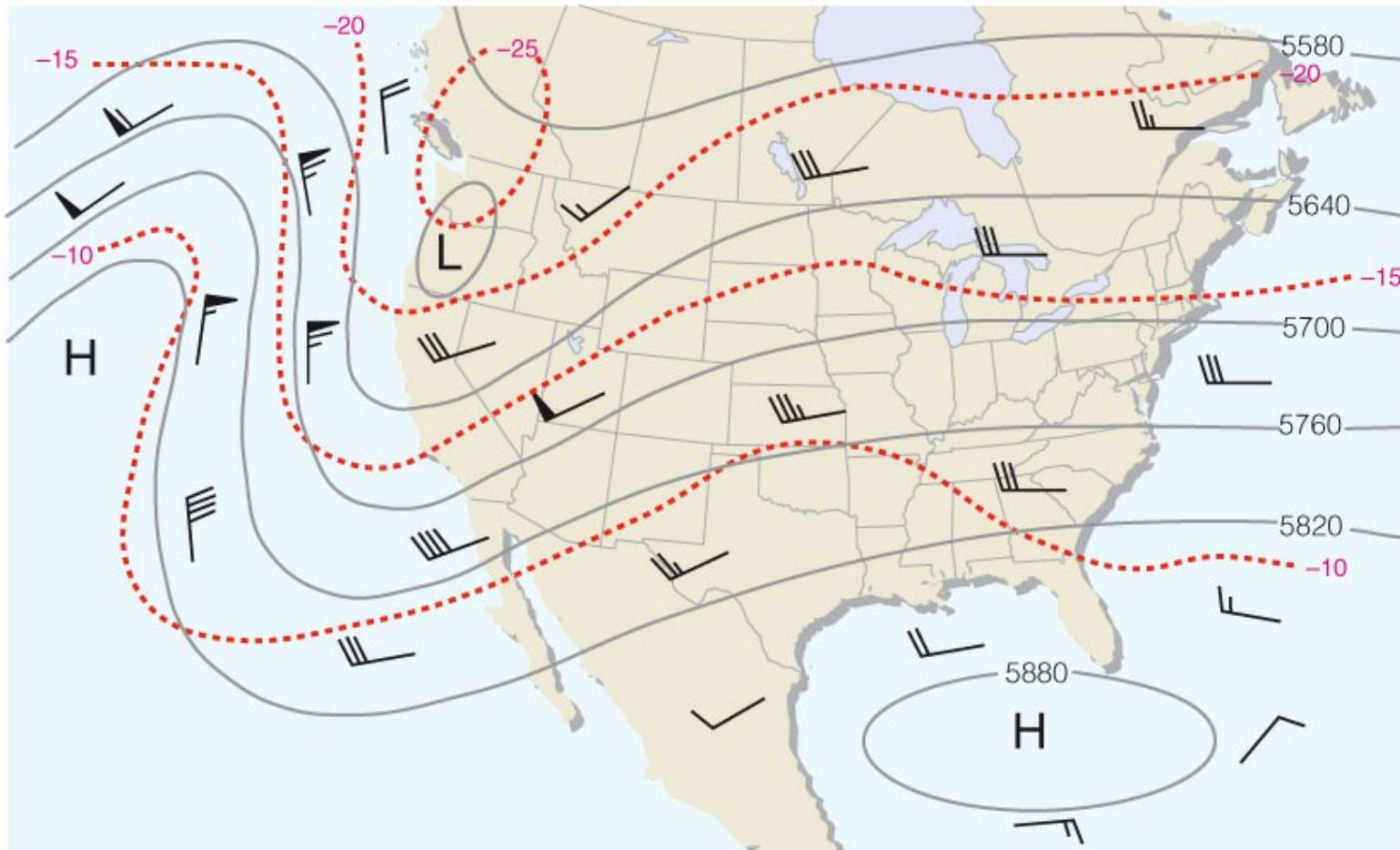

	Miles (statute) per hour	Knots
☉	Calm	Calm
—	1–2	1–2
↘	3–8	3–7
↘↘	9–14	8–12
↘↘↘	15–20	13–17
↘↘↘↘	21–25	18–22
↘↘↘↘↘	26–31	23–27
↘↘↘↘↘↘	32–37	28–32
↘↘↘↘↘↘↘	38–43	33–37
↘↘↘↘↘↘↘↘	44–49	38–42
↘↘↘↘↘↘↘↘↘	50–54	43–47
↘↘↘↘↘↘↘↘↘↘	55–60	48–52
↘↘↘↘↘↘↘↘↘↘↘	61–66	53–57
↘↘↘↘↘↘↘↘↘↘↘↘	67–71	58–62
↘↘↘↘↘↘↘↘↘↘↘↘↘	72–77	63–67
↘↘↘↘↘↘↘↘↘↘↘↘↘↘	78–83	68–72
↘↘↘↘↘↘↘↘↘↘↘↘↘↘↘	84–89	73–77
↘↘↘↘↘↘↘↘↘↘↘↘↘↘↘↘	119–123	103–107

# Horizontal Forces & Circulation

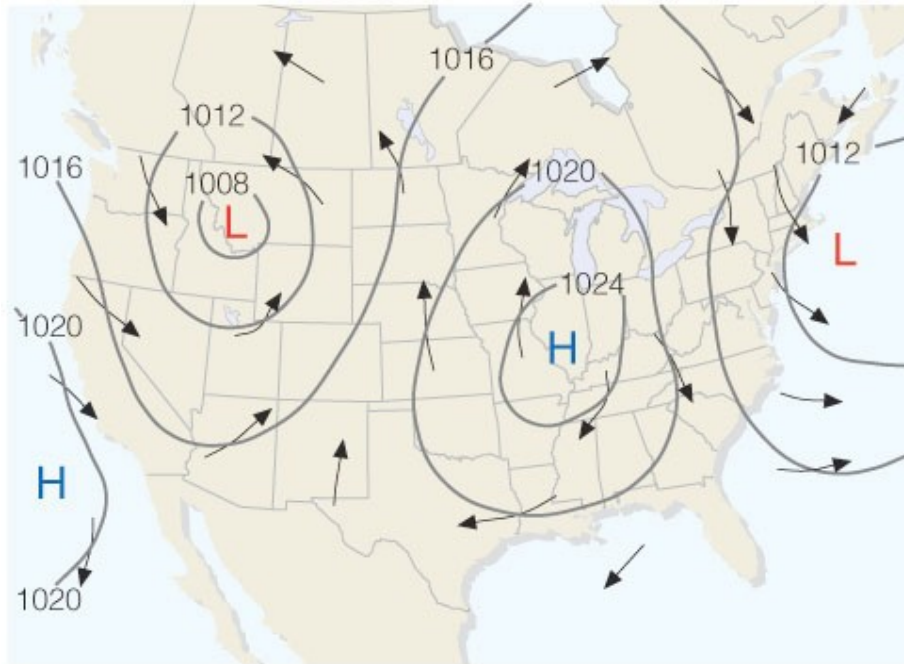

(a) Surface map

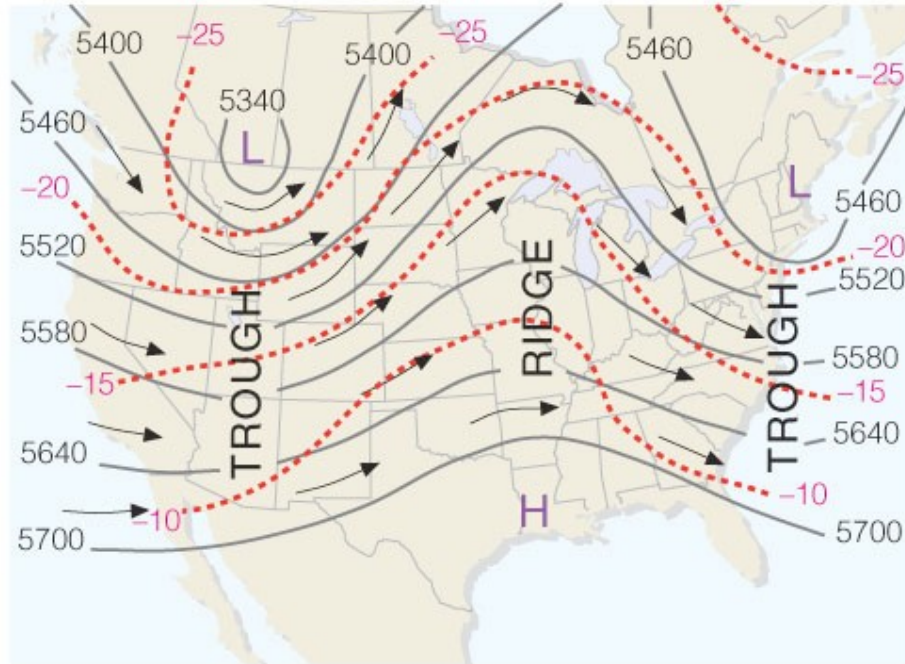

(b) 500-millibar map

- If the *horizontal* pressure gradients last long enough (longer than several hours) or the air displacement is large enough (1000 of km)
  - ◊ The rotation of the earth greatly affects the motion (Coriolis Force)
- In this case, the *horizontal* pressure gradients are balanced by Coriolis Force, and the wind blows along a line of *constant* pressure and is said to be in *geostrophic balance*
- E.g., day to day weather, mid-latitude storms, jet stream, monthly flows , seasonal flows ..



Jet  
Hei  
Sur  
Gel

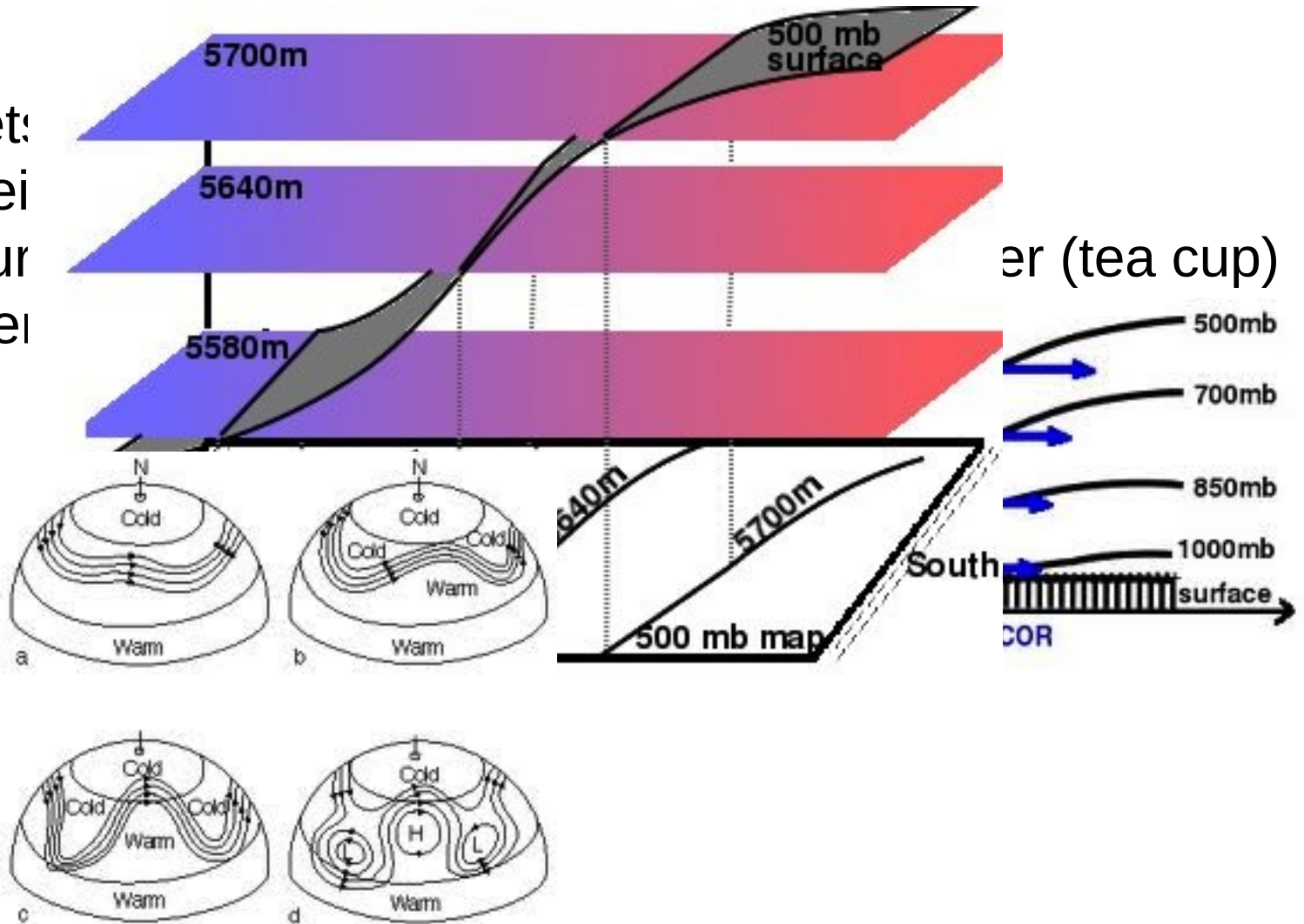

# Jets

- The air column in the tropics is warmer than that at the poles. Hence, the density is less in the tropics so going up into the atmosphere, pressure drops more slowly in the tropics than in the polar regions

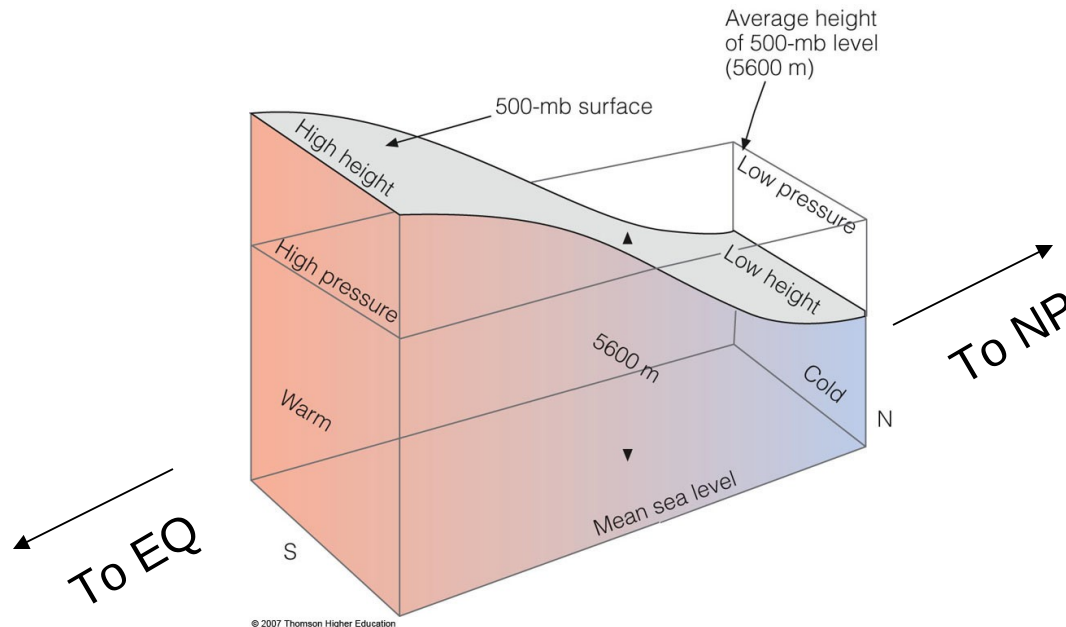

- Hence, a poleward pressure gradient develops as you go up from the surface

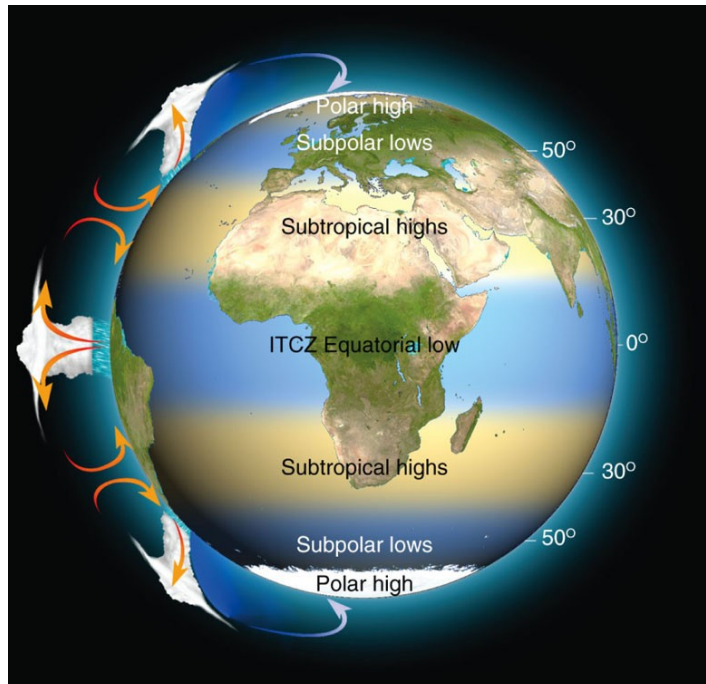

# Coriolis Effect

- If the *horizontal* pressure gradients last long enough (longer than several hours) or the air displacement is large enough (1000s of km), rotation of the earth greatly affects the motion ...
- In these cases, the air experiences the Coriolis Effect (or Force) which is a frame-of-reference effect
- The Coriolis Force is the combined effect of
  - Observer's reference frame (on earth) is rotating
  - Gravity acting to keep air on the spherical Earth

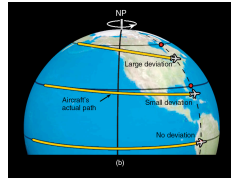
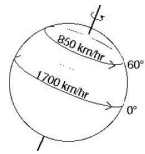

In the net, air moving in the northern hemisphere experiences an *apparent force* to the right of motion

# The Horizontal Wind is nearly Geostrophic

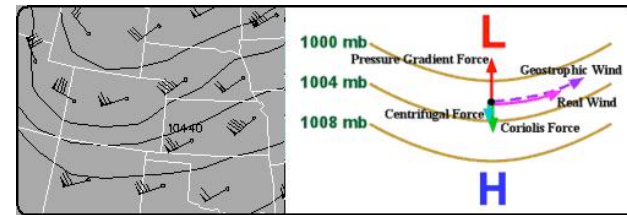
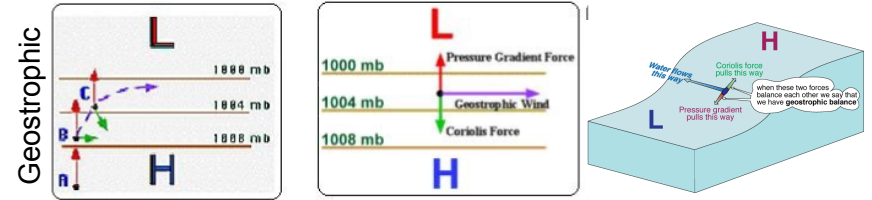

Nearly Geostrophic Flow (it is curved)

Northern Hemisphere

# The Horizontal Wind is nearly Geostrophic

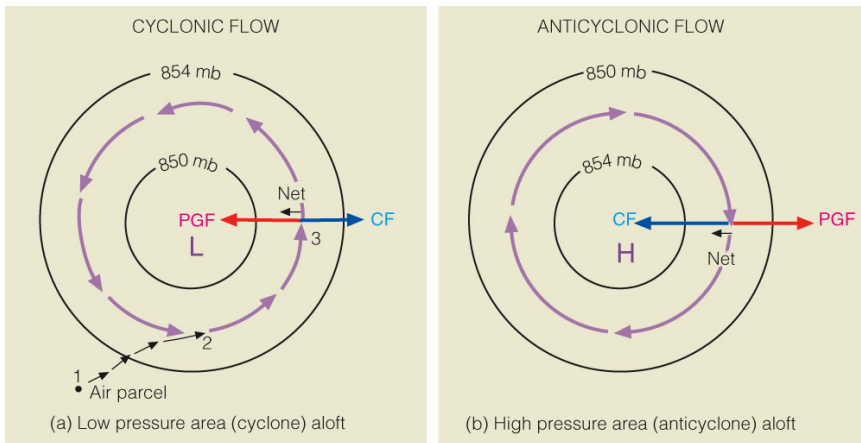

Northern Hemisphere

# Geostrophic Wind

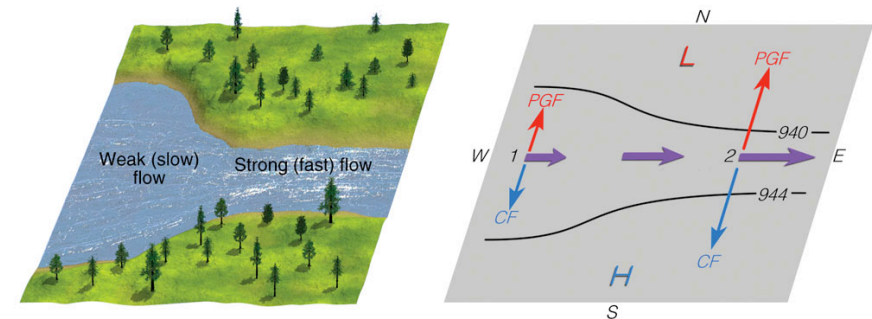

The stronger the  $PGF_v$ , the stronger the CF (hence, the stronger the wind)

# Mapping Pressure Gradients

The height of the 500mb contour on this day

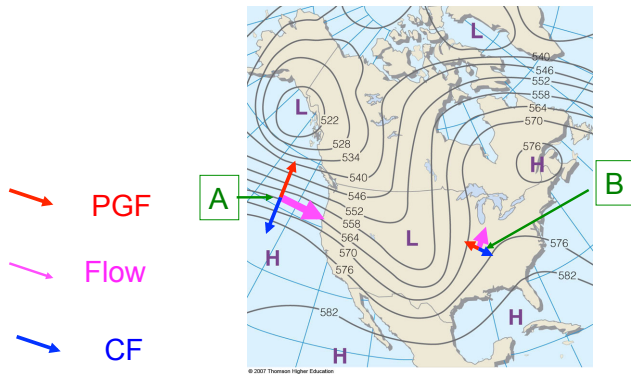

- Read this just like a pressure map on constant elevation
  - flow is along a line of constant height
  - flow is strongest where the lines are closest together (stronger gradients = stronger CF ~ stronger wind)

# The flow at ~ 5.6km is nearly Geostrophic

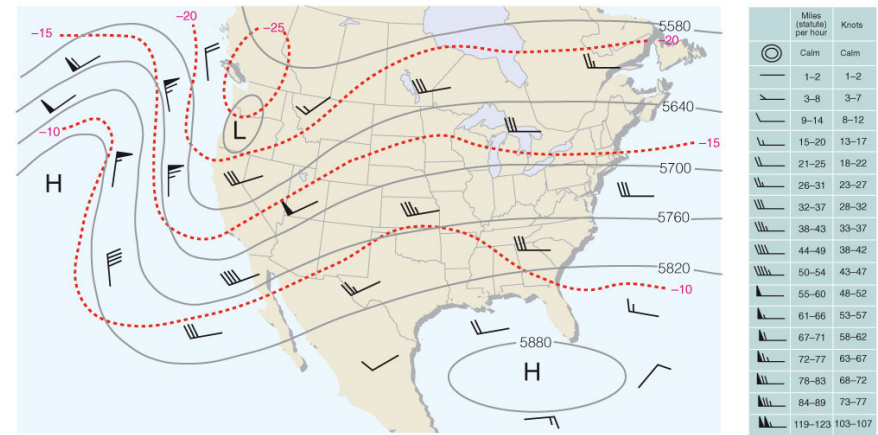

- The flow is nearly perfect geostrophic balance
  - ✧ the horizontal pressure gradients are balanced by Coriolis Force, and the wind blows along a line of constant pressure
- E.g., day to day weather, mid-latitude storms, jet stream, monthly flows, seasonal flows ..

# The Horizontal Wind is nearly Geostrophic

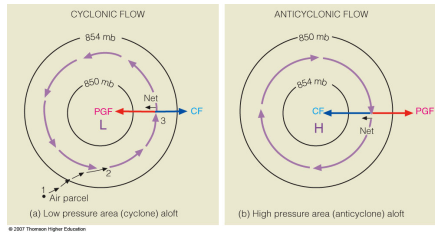

Northern Hemisphere

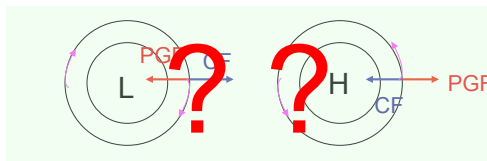

Southern Hemisphere

The CF acts to accelerate the air to the left of the motion in the Southern Hemisphere

# Horizontal Forces & Circulation

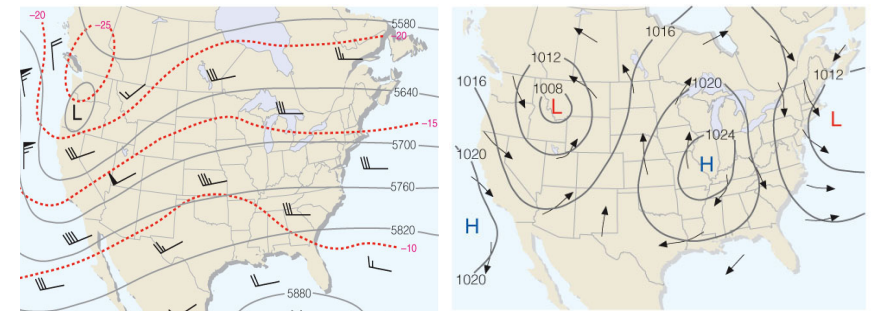

(a) Surface map

- Aloft, the flow is nearly in perfect geostrophic balance (PGF balanced by CF), so the flow is along an isobar- a line of constant pressure.
- What about the flow near the surface? Is it in geostrophic balance?

## Near Surface Winds

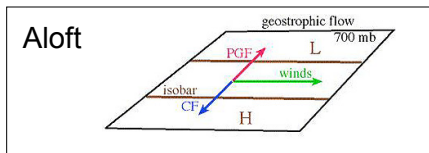

Away from the surface, winds are nearly geostrophic  
 $PGF_H = CF$

But near the surface, winds feel  $PGF_H$ , CF *and* friction

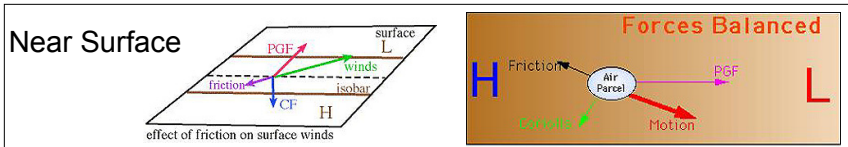

Averaged over many hours, the net force balance is zero. Hence, at the surface there is a small component to the wind that blows toward the low pressure.

Hence, air tends to flow out of a surface high, causing sinking motion and convergence aloft (fair weather)

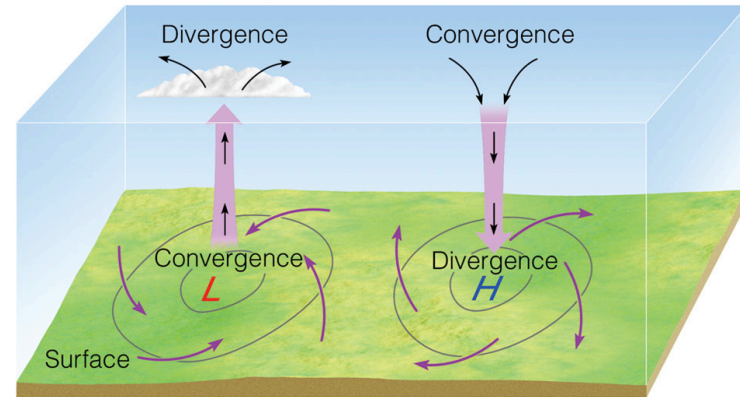

© 2007 Thomson Higher Education

Conversely, air tends to flow into of a surface low, causing convergence and rising motions aloft (cloudy)

A very good analog for the Surface Low

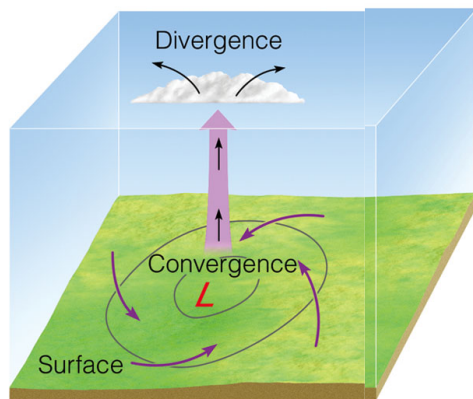

Why are there atmospheric jets?

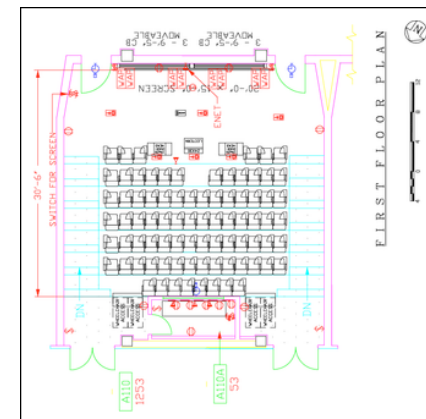

# Why are there atmospheric jets?

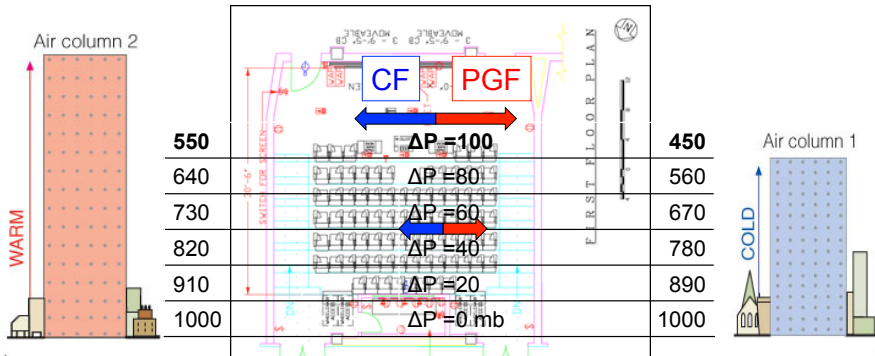

Geostrophic balance, so wind is out of the page (NH)

$\Delta P$  increases and density decreases as you go up  $\rightarrow$  increasing PGF  $\rightarrow$  increasing CF  $\rightarrow$  increasing wind speed as you go up

# Jets

- The air column in the tropics is warmer than that at the poles  $\rightarrow$  density is less in the tropics. Hence, going up into the atmosphere, pressure drops more slowly in the tropics than in the polar regions

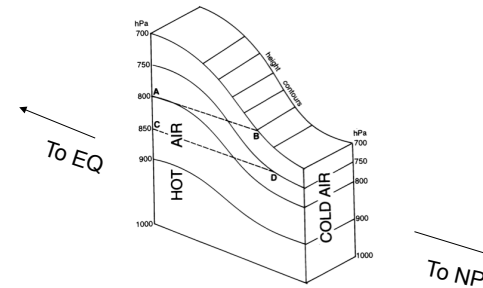

- Hence, a poleward pressure gradient develops as you go up from the surface

# Jets

- A poleward horizontal pressure gradient develops and strengthens as you go up
- Air density decreases too, so the  $PGF_H$  becomes huge. Hence, the winds increase as you go up.

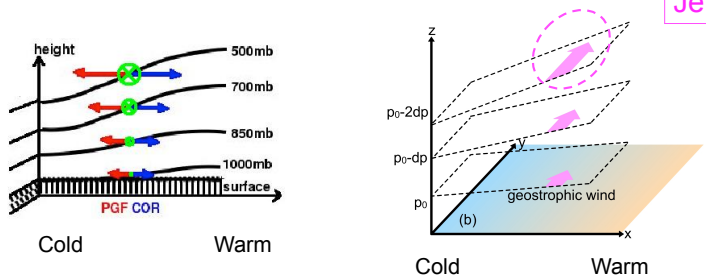

Jet

# Climatological Winds at 200mb up

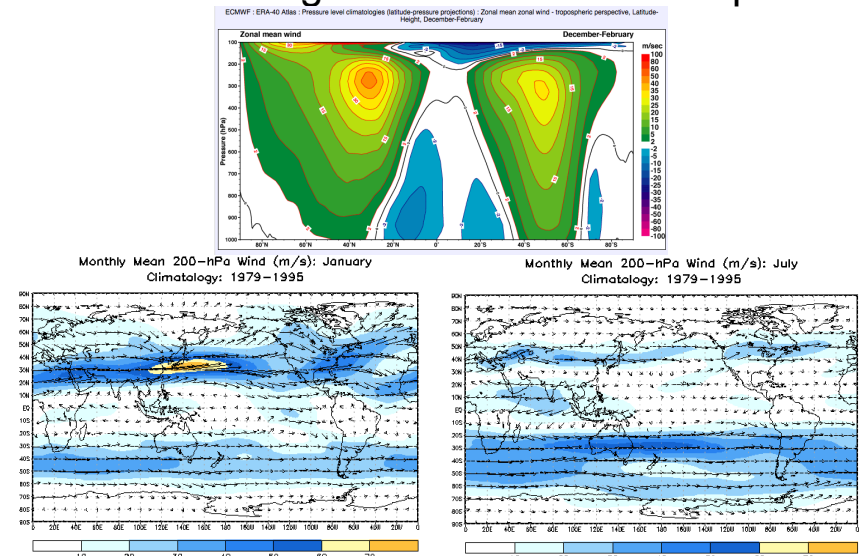

# “General Circulation”

- Usually described as the time-averaged flow for a month, season or year
- The gross aspects of the essential General Circulation can be explained by considering a rotating planet the size of Earth and with roughly the same GH gases, without worrying about continents and mountain ranges

# “General Circulation”

- More energy is absorbed in the tropics than is emitted to space.
- Less energy is absorbed in the polar regions than is emitted to space.

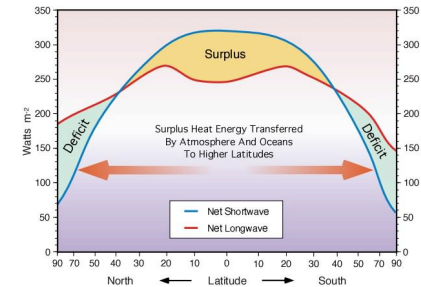

- As a result the tropics are warmer than the polar regions *and* the subsequent pressure gradients drive circulation that move the excess heat in the tropics to the poles

## Slowly Rotating Earth

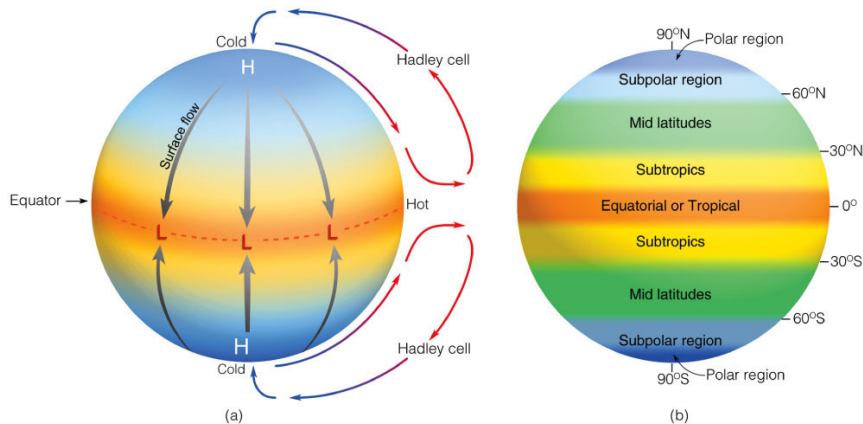

© 2007 Thomson Higher Education

Like a *large scale sea-breeze* (hot tropics/cold poles)

## Idealized Model of Realistic Rotating Earth (24hrs)

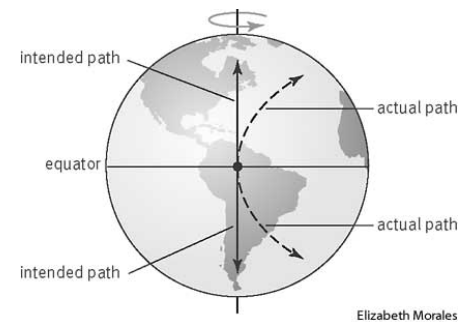

To conserve angular momentum, moving air at rest from the equator to X° N or S would have to be moving eastward at ...

Latitude X	Eastward Speed
Equator	0 m/s (540m/s as seen from space)
20°	58 m/s
45°	375 m/s

*The Equator-to-Pole Cell is broken because conservation of angular momentum creates large shear in the flow, which wobbles and creates storms*

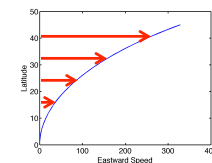

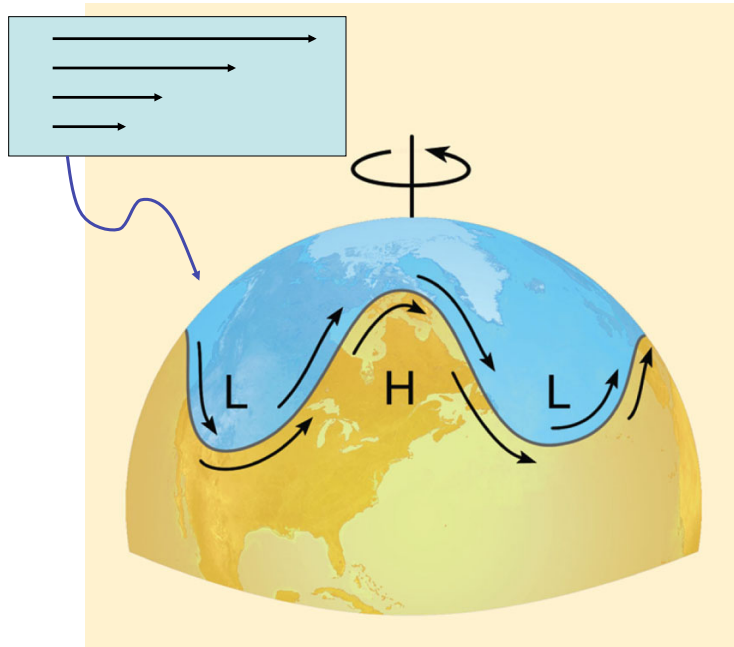

© 2007 Thomson Higher Education

Fig. 3, p. 266

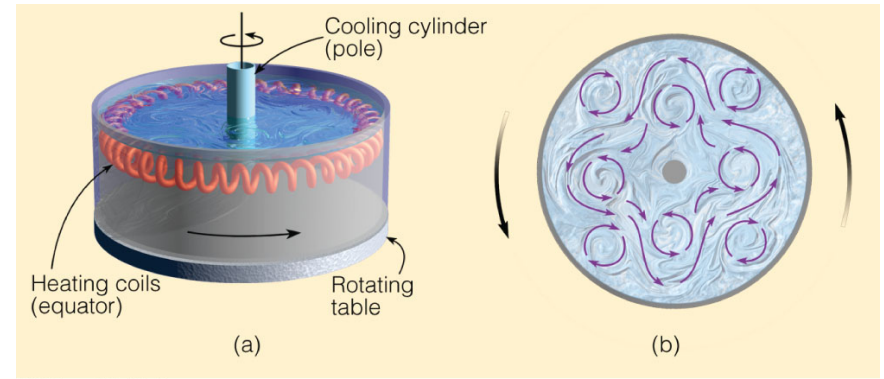

© 2007 Thomson Higher Education

### Watch the Movie

[www.youtube.com/watch?v=lmNxEMv85IA](http://www.youtube.com/watch?v=lmNxEMv85IA)

Stable Flow: <http://www.youtube.com/watch?NR=1&feature=endscreen&v=olKFj6g-nPw>

Storms like this one account for about 2/3 of the total heat moved from equator-to-pole by circulation

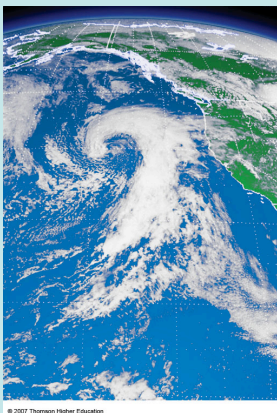

© 2007 Thomson Higher Education

Typical mid-latitude cyclone

Hence, equator-to-pole differences in radiation give rise to equator-to-pole temperature differences and hence circulation.

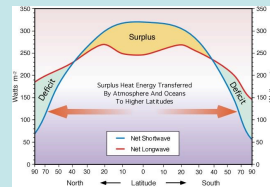

In turn, circulation moves excess energy from the equator to the poles (cooling the tropics and warming the poles)

### IR Movie

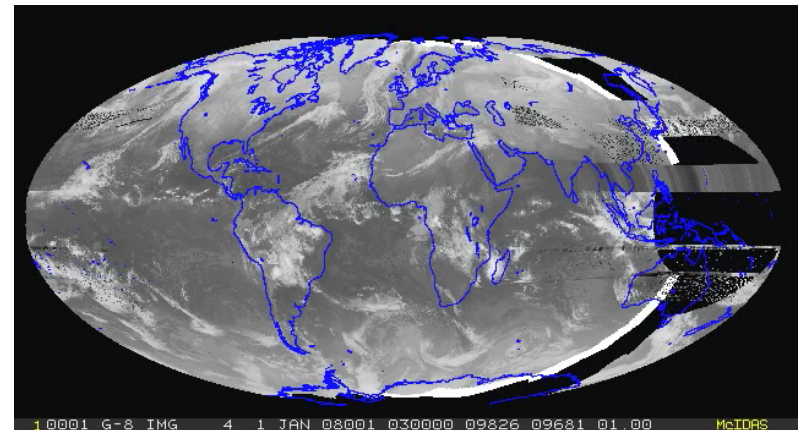

### Idealized Model of Realistic Rotating Earth (24hrs)

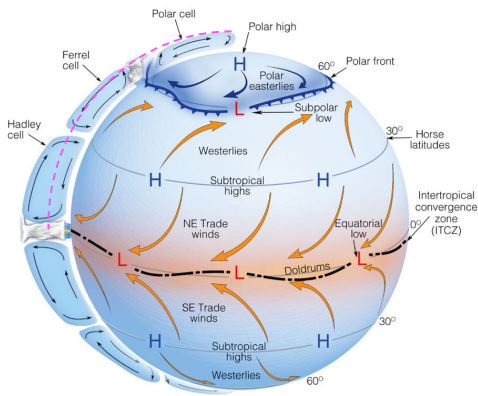

Rotation causes the circulation to form three “cells” in each hemisphere: Hadley, Ferrel and Polar Cells

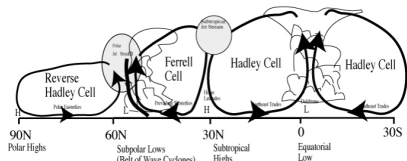

### Idealized Model of Realistic Rotating Earth (24hrs)

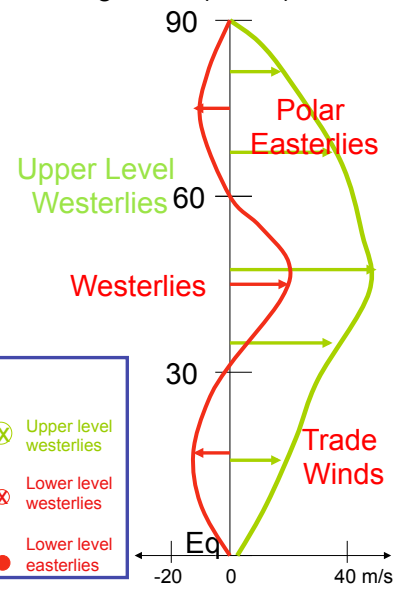
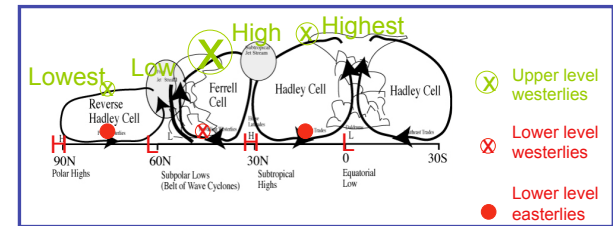
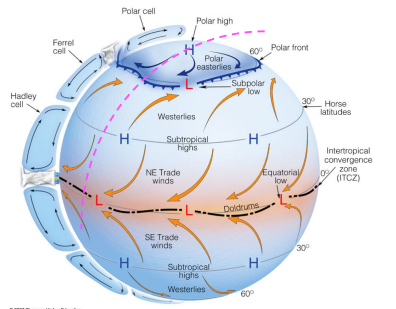

### Idealized model of the “General Circulation”

- Hadley Cell in tropics is similar to the land-sea breeze, but CF matters (why?)
  - Hence, surface flow is westward (easterly) at surface and eastward (westerly) aloft
- The largest north-south temperature gradients are in the midlatitude (between the tropics and the polar regions)
  - Hence, the largest equator-to-pole pressure gradient is in the midlatitude. Westerly JETS are located here

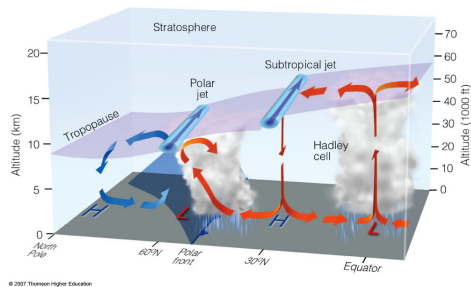

### Idealized model of the “General Circulation”

- In general, there is rising motion near the equator and at ~60° latitude, and sinking motion at 30° latitude and near the poles. Hence, the
  - deep tropics and 60° latitude are wet regions
  - subtropics (20-35° latitude) and polar region are dry regions

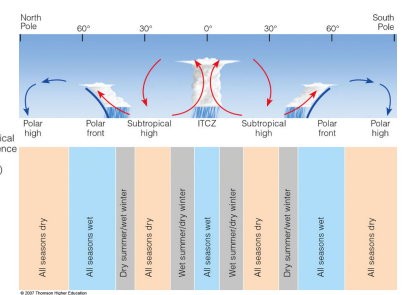
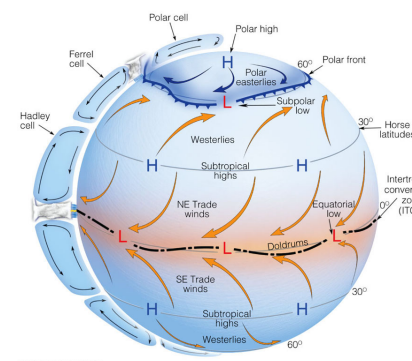

# Idealized model of the “General Circulation”

- Near the surface, in general, there are
  - easterlies (Trade Winds) in the tropics and subtropics (25°S-25°N)
  - westerlies in the midlatitudes (30-60° latitude)
  - easterlies in the polar regions (60-90° latitude)
- Aloft (near the tropopause) there are westerlies everywhere, but strongest westerlies are in the midlatitudes

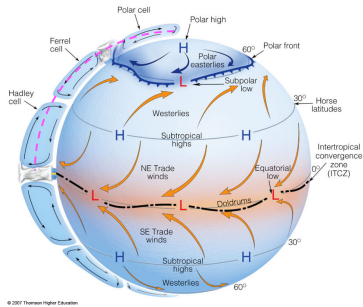

# The Real World?

Climatological sea-level pressure and surface wind-flow patterns for January

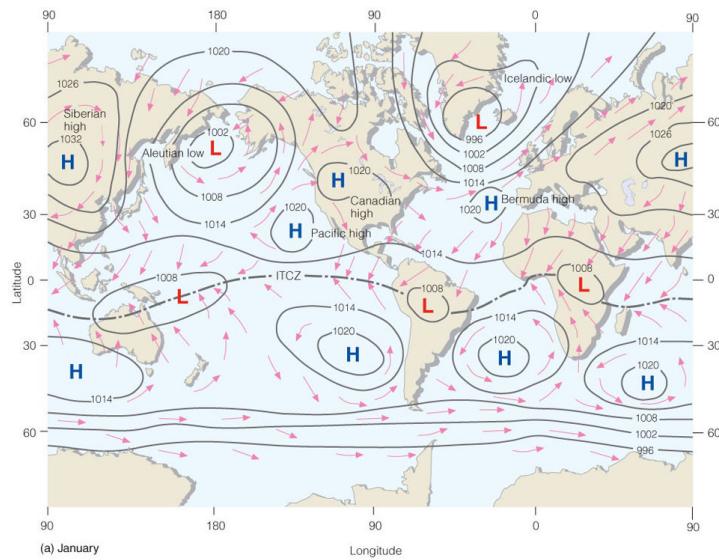

(a) January The heavy dashed line represents the position of the ITCZ/surface Low Pressure

Climatological sea-level pressure and surface wind-flow patterns for January

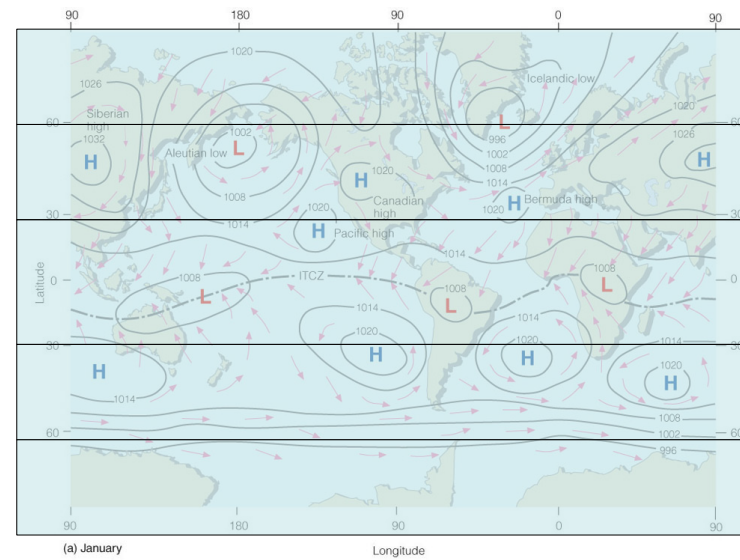

(a) January The heavy dashed line represents the position of the ITCZ/surface Low Pressure

Climatological sea-level pressure and surface wind-flow patterns for January

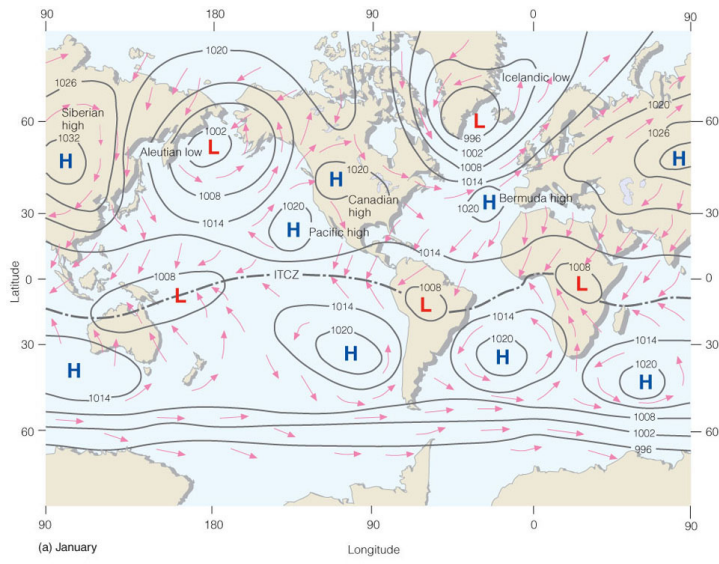

(a) January  
The heavy dashed line represents the position of the ITCZ/surface Low Pressure

Climatological sea-level pressure and surface wind-flow patterns for July

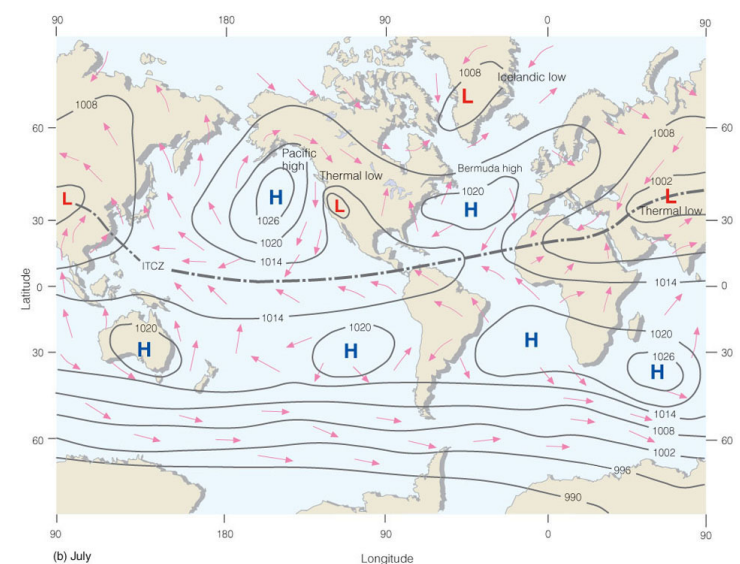

(b) July  
The heavy dashed line represents the position of the ITCZ/surface Low Pressure

Look at East-West Differences in midlatitude NH

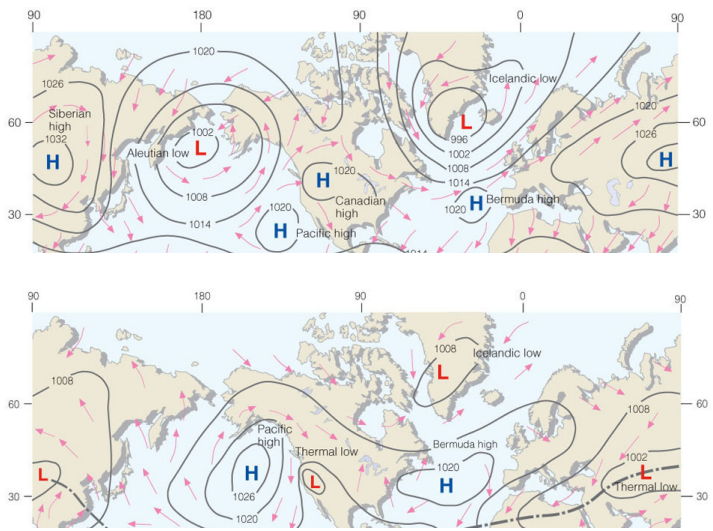

January

July

What Season is this?

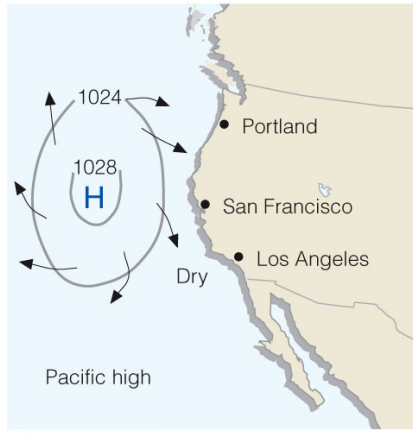

© 2007 Thomson Higher Education

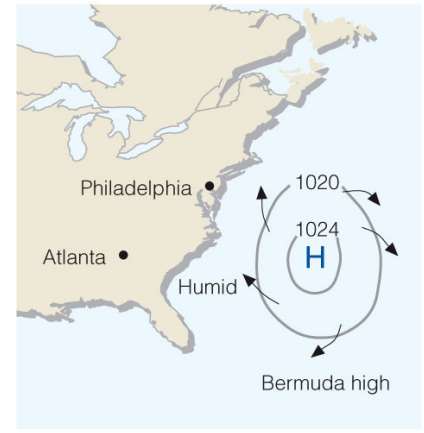

Climatological height of 500mb surface, temperature at 500mb, and wind direction

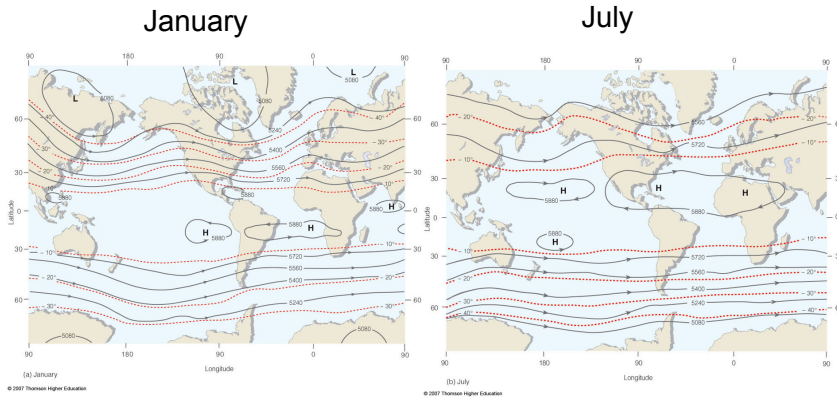

Largest north-south temperature gradients in winter months. Hence, strongest westerlies in midlatitudes of *both* hemispheres in winter!

### Climatological Precipitation (annual ave)

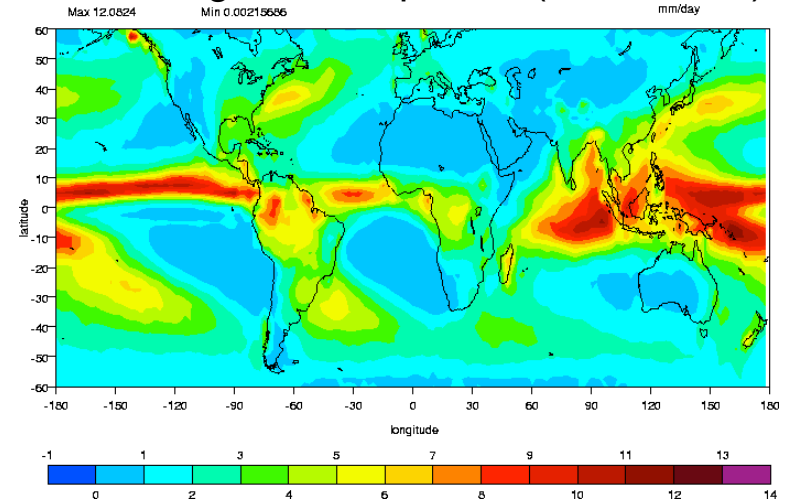

Where are the deserts? Where are the wet regions?

### Precipitation Climatology (zonal average)

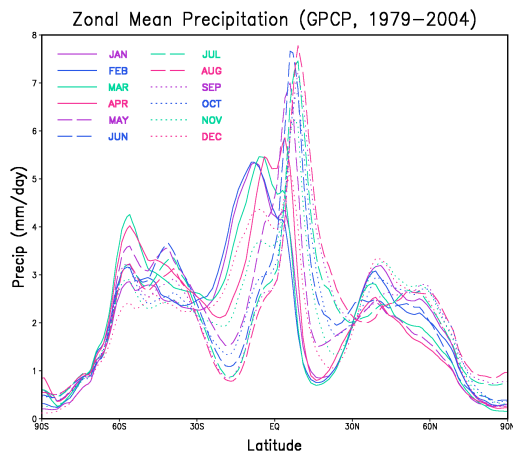

(zonal = east to west)

Circulation moves excess energy from Equatorial to polar regions

### Northward Energy Transport

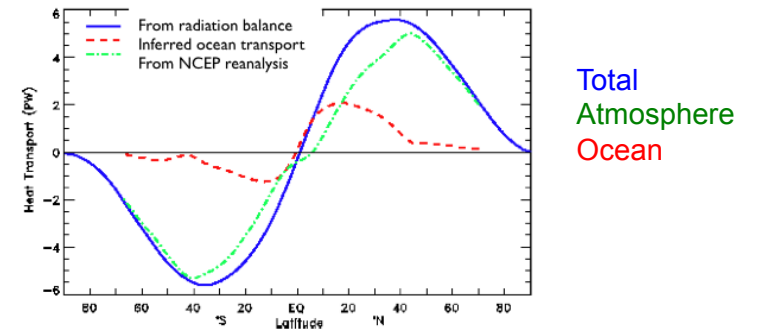

Ocean does most of the transport in the deep tropics (15°S-15°N)

Atmosphere (midlatitude storms) does most of the transport poleward of 30°N,S

# Role of the Major Mountain Ranges

Observed near surface wind and wind speed

Observed DJF near surface wind

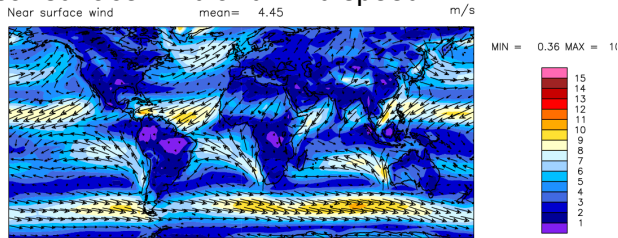

Observed DJF surface temperature

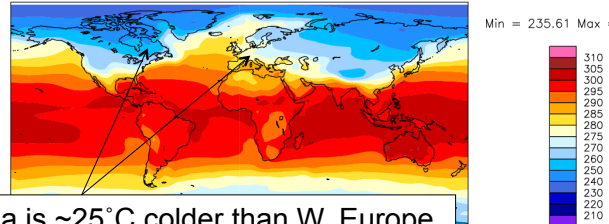

E. Canada is ~25°C colder than W. Europe

# The impact of mountains on DJF temperature

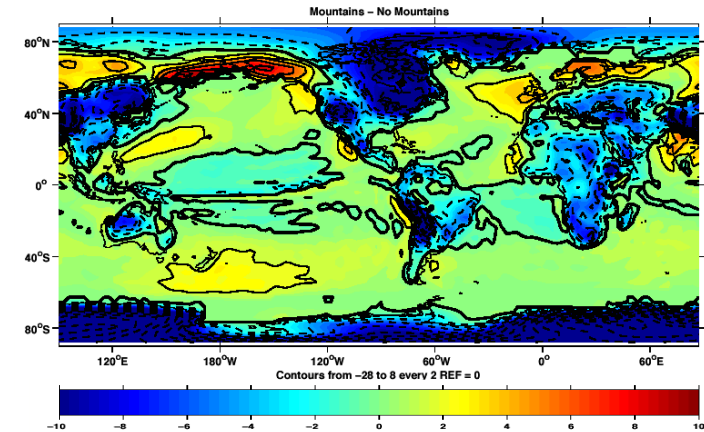

Without the Rockies, the Northeast US would be ~12°C warmer and Alaska would be 8-10°C colder

Europe is "warm" in winter because of the Rockies and atmospheric heat transport

Seager et al 2002

# Mountains and Rotation of Earth Matter

DJF Climate on a Backward Rotating Earth

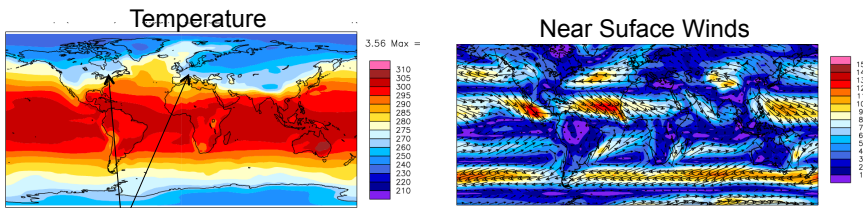

NE US is ~10°C warmer than W. Europe

Backward minus Forward

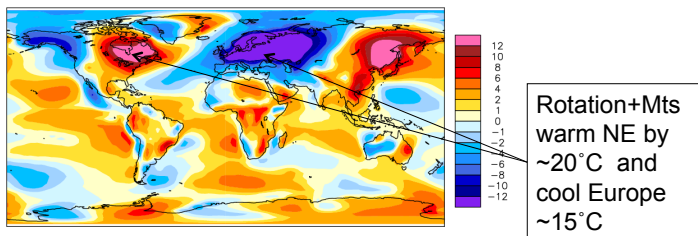

Rotation+Mts warm NE by ~20°C and cool Europe ~15°C

# Why is Europe warm in winter (compared to New England)?

Europe minus New England Temperature (DJF)

Observed	25°C
The Rockies	12°C
Westerlies blowing over wet motionless ocean	12°C
Gulf Stream (ocean currents)	1°C
<b>Total</b>	<b>25°C</b>

## The Ice Ages

- The Ice Ages lasted 2.7 Myr BP to about 10,000 yrs ago

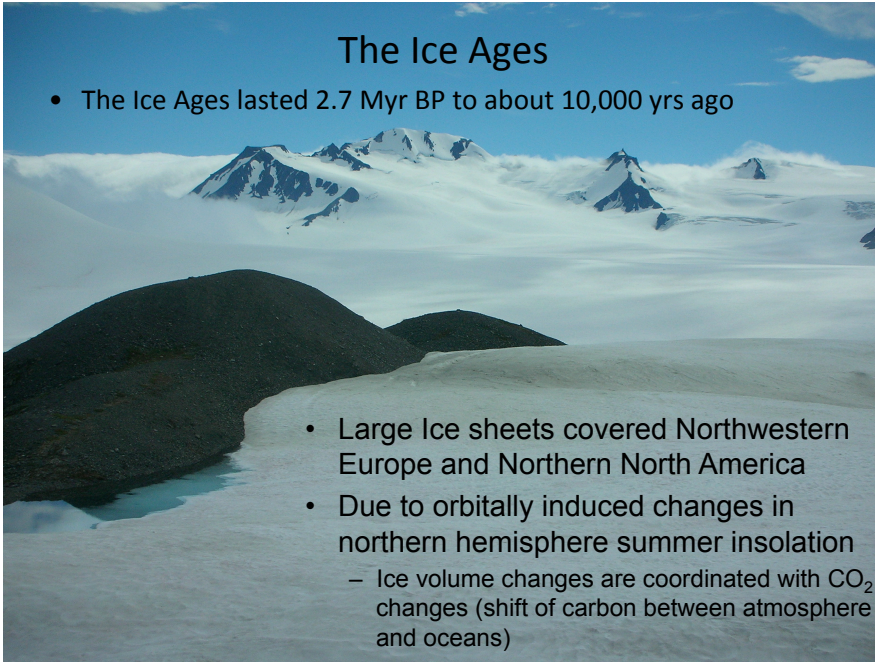

- Large Ice sheets covered Northwestern Europe and Northern North America
- Due to orbitally induced changes in northern hemisphere summer insolation
  - Ice volume changes are coordinated with CO<sub>2</sub> changes (shift of carbon between atmosphere and oceans)

## Geologic Evidence For the Ice Ages

- Moraines, erratics, pollen records, etc
- Ocean sediments
  - Oxygen Isotopes in the shells of organism in the deep sea provide evidence of global ice volume
- Ice core records
  - Oxygen isotopes record local temperature
  - Air bubbles provide record of CO<sub>2</sub> and other gases
  - Remarkable correlation between local temperature and CO<sub>2</sub>
- Cause of glacial cycles
  - Trigger involves changes in summer insolation in northern hemisphere due to orbital changes
  - Ice-albedo and water vapor feedbacks are important
  - CO<sub>2</sub> is coordinated with the changes in ice volume, but it is a minor feedback to the Ice Ages (mainly responsible for SH cooling)

## Evidence of Glaciations: Moraines



Tasman Glacier, NZ

Moraines and erratics can be dated

Mueller Glacier, NZ

## What does an ice age look like?

### The Puget Sound Lobe

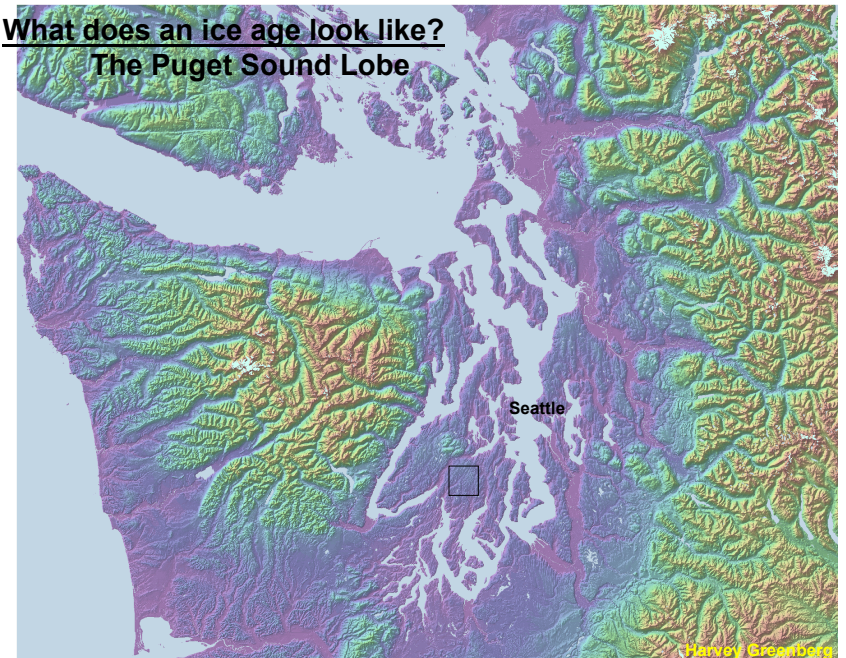

Harvey Prossberg

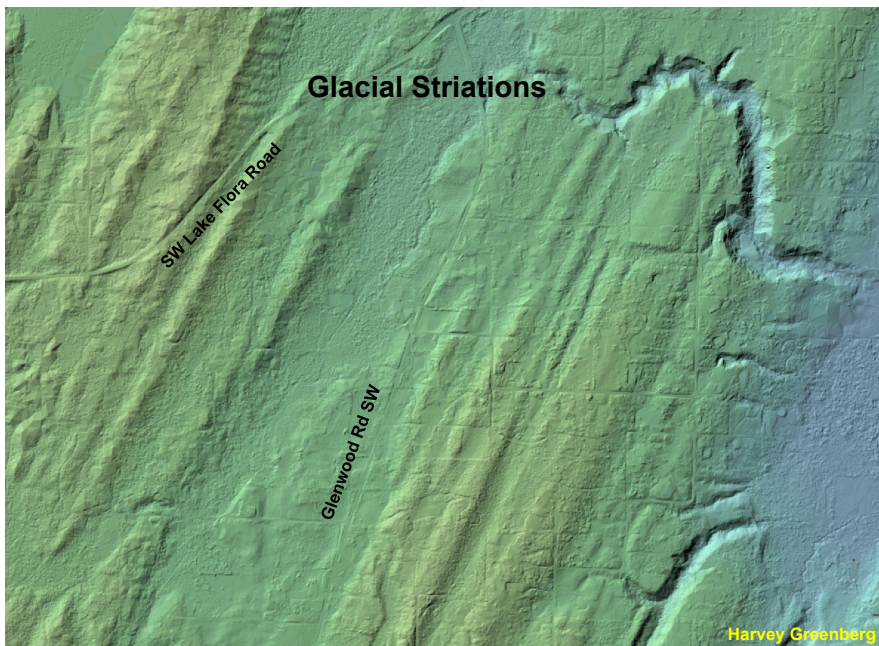
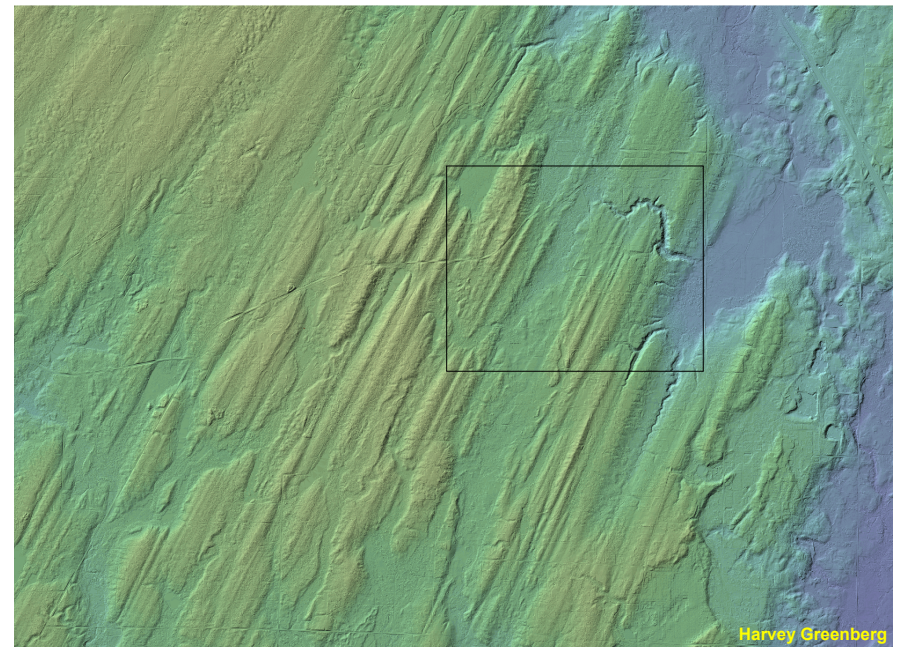
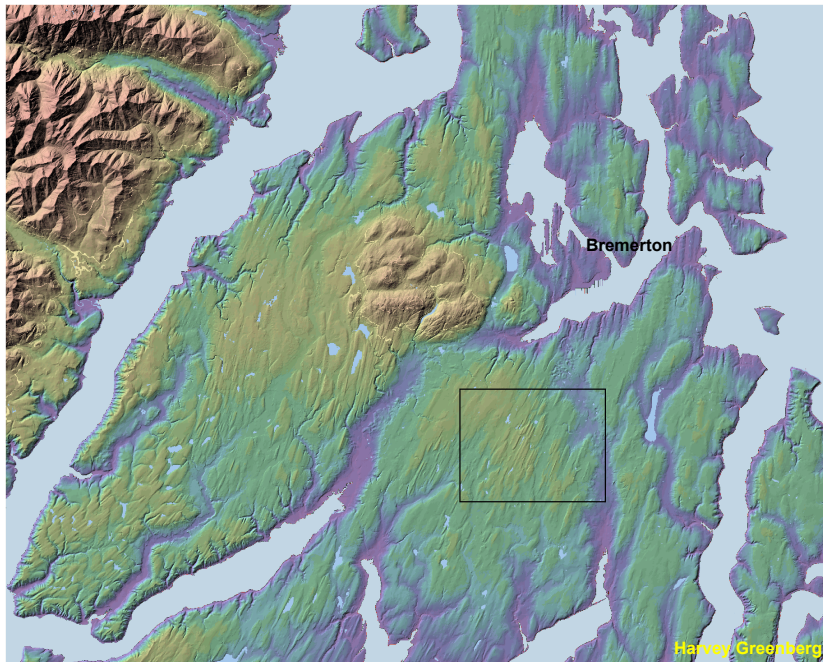

**What does an ice age look like?**

**Last Glacial Maximum Conditions**

- The Ice sheets
  - Extent determine by landscape morphology (e.g, moraines)
  - Volume determined by isotopes in ocean sediment cores
  - Shape determined by ice sheet models and present-day

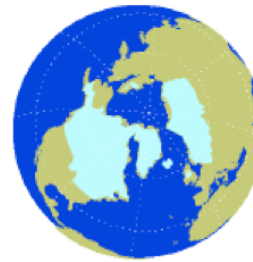

**Last Glacial Maximum**

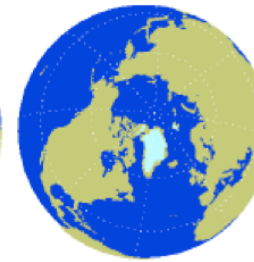

**Present**

Global sea level was 125 meters lower than today!

Large Ice sheets covered Northwestern Europe and Northern North America; the ice sheet was up to 5 km thick over Canada; 1-2km over Washington

Greenland 25°C colder, tropics 4°C colder

# Geologic Evidence For the Ice Ages

- Moraines, erratics, pollen records, etc
- Ocean sediments
  - Oxygen Isotopes in shells of organism in deep sea provide evidence of glacial ice amount



- Ice core records
  - Oxygen isotopes record local temperature
  - Air bubbles provide record of CO<sub>2</sub> and other gases



National Ice Core Freezer in NH

## Isotopic Evidence

H<sub>2</sub><sup>16</sup>O vs H<sub>2</sub><sup>18</sup>O  
 "light" (normal) vs "heavy"

- evaporation selects for "light water"
- condensation (precipitation) selects for "heavy water"

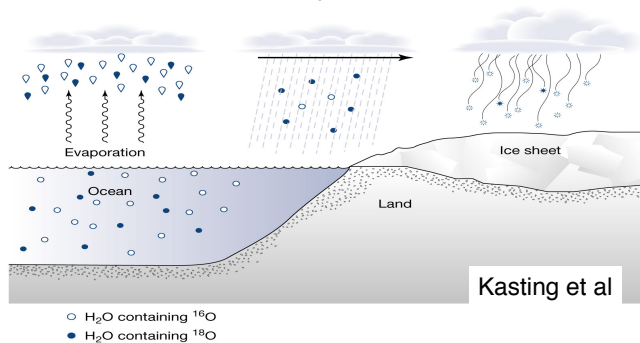

<sup>18</sup>O in ocean sediments records glacial ice volume: "lighter water" in ice-sheets means remaining ocean water is "heavier".

<sup>18</sup>O in ice-cores indicates local temperature: Colder conditions means more precipitation en route so "lighter" snow.

# Vocabulary: Isotopes

**an atom (or element) is defined by number of protons**  
 H(1), C(6), O(8), Pb(82)

**atomic mass: number of protons plus neutrons**  
 H normally 1+0 = 1  
 C normally 6+6 = 12  
 O normally 8+8 = 16

**isotope: same element, different atomic mass**  
**>> that is, different number of neutrons**  
<sup>1</sup>H (normal), <sup>2</sup>H (deuterium), <sup>3</sup>H (tritium; radioactive)  
<sup>12</sup>C (normal), <sup>13</sup>C, <sup>14</sup>C (radioactive)  
<sup>16</sup>O (normal), <sup>18</sup>O

## Basic Idea

No land ice (interglacial)

Ocean Composition  
 40 H<sub>2</sub><sup>18</sup>O  
 4000 H<sub>2</sub><sup>16</sup>O  
 $\frac{H_2^{18}O}{H_2^{16}O} = 0.0100$

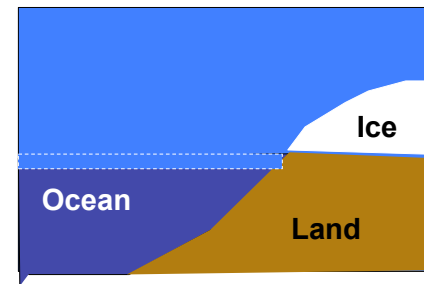

Lots of land ice (glacial)

Ice Sheet Composition  
 1 H<sub>2</sub><sup>18</sup>O  
 150 H<sub>2</sub><sup>16</sup>O  
 $\frac{H_2^{18}O}{H_2^{16}O} = 0.0067$

Ocean Composition  
 40 - 1 = 39 H<sub>2</sub><sup>18</sup>O  
 4000 - 150 = 3850 H<sub>2</sub><sup>16</sup>O  
 $\frac{H_2^{18}O}{H_2^{16}O} = 0.01013$

**Light water accumulates in ice sheets and ocean gets relatively heavy**

# The ice volume time series

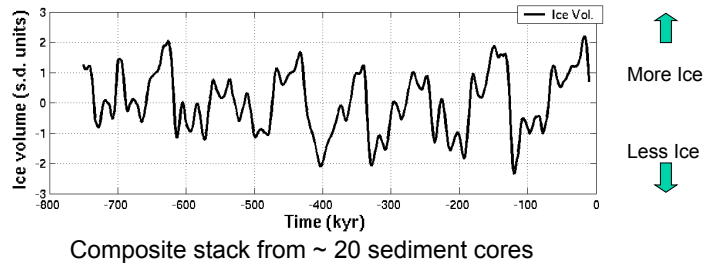

- the fraction of  $^{18}\text{O}$  to  $^{16}\text{O}$  in the shells of organisms preserved in deep sea sediment cores is proportional to ice volume:

"lighter water" stored in ice-sheets means remaining ocean water is "heavier". Critters in ocean grow shells that contain material with the isotopic composition of the ocean water.

Imbrie et al., 1984

# 3 Million Year Record of Global Ice Volume

## Oxygen Isotope Concentration in Shells of Organisms Growing in the Deep Ocean

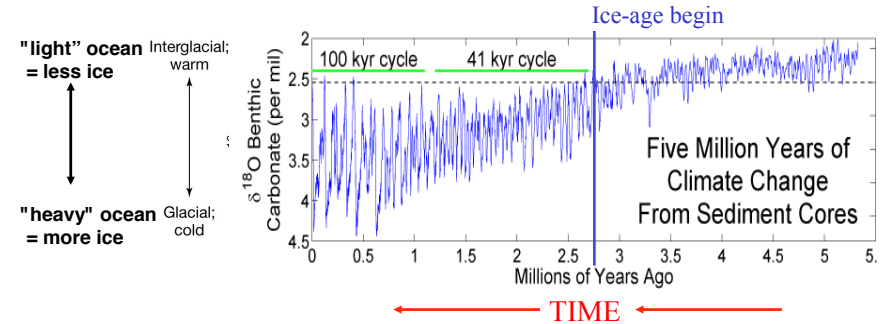

- Early on, 40,000 year cycles dominated
  - Obliquity having a direct effect
- More recently, 100,000 year cycles have been most prevalent

# 3 Million Year Record of Global Ice Volume

## Short (10,000 yr long) Warm Episodes

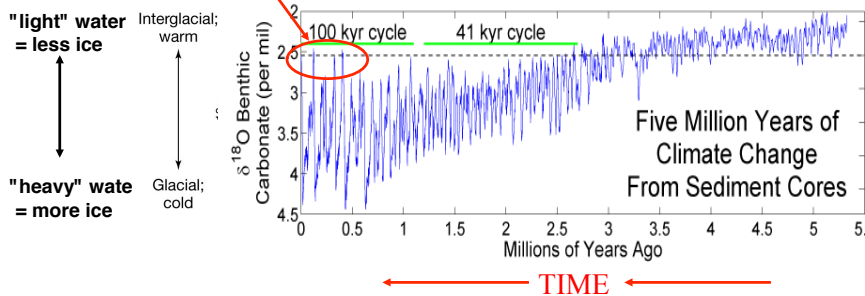

Kasting et al

# CO<sub>2</sub>\*, CH<sub>4</sub>\* and Temperature in Vostock Antarctica

\*CO<sub>2</sub> and CH<sub>4</sub> are well mixed in the atmosphere, so this is also a global record of CO<sub>2</sub> & CH<sub>4</sub>

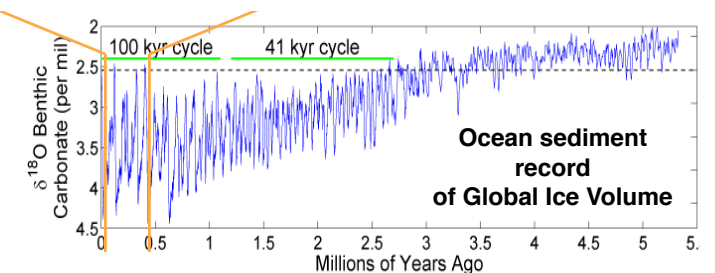
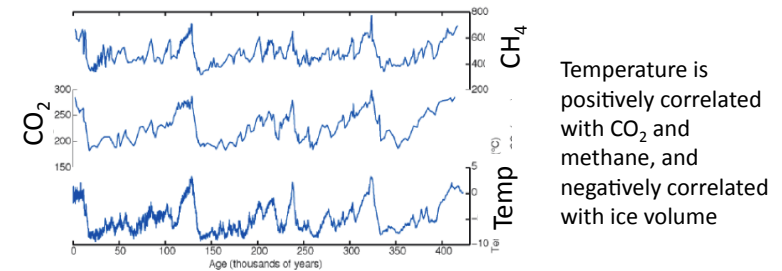

## The Theory of Ice Ages

- The Ice Ages lasted 2.7 Myr BP to about 10,000 yrs ago

- Cause of glacial cycles

- Trigger involves changes in summer insolation in northern hemisphere due to orbital changes
- Ice-albedo and water vapor feedbacks are important
- CO<sub>2</sub> is coordinated with the changes in ice volume, (shift of carbon between atmosphere and oceans), but CO<sub>2</sub> is a minor feedback to the Ice Ages (mainly responsible for SH cooling)

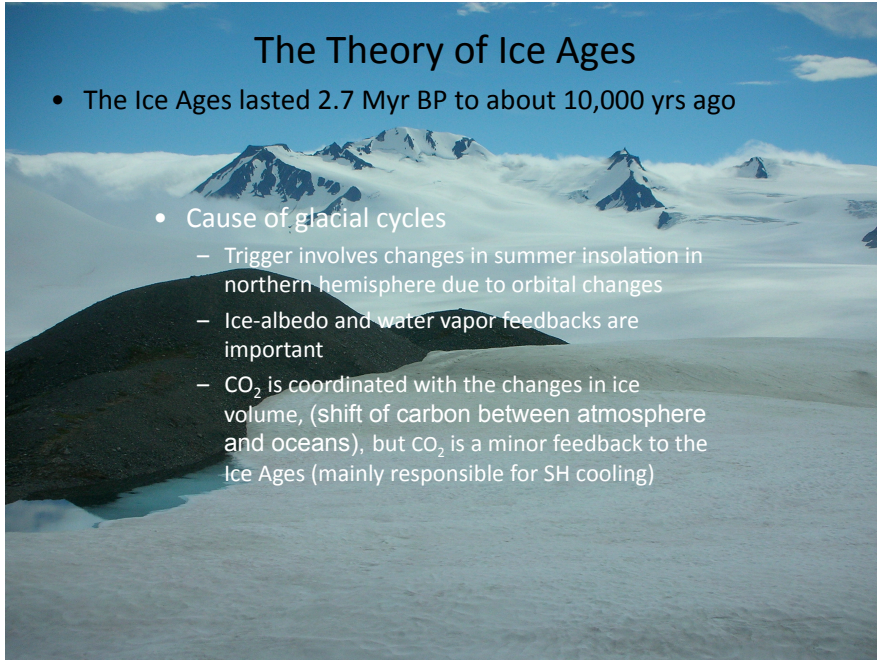

## Theory of the Ice Ages:

Orbital induced insolation changes and global ice volume

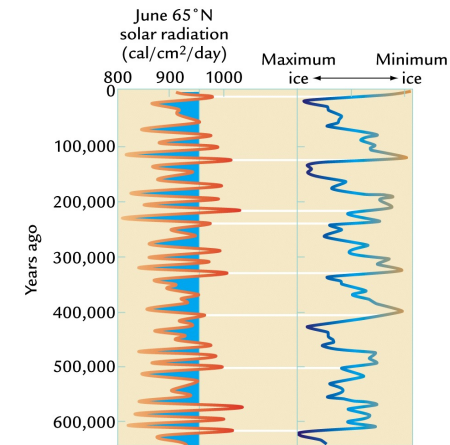

“Strong insolation in NH summer causes rapid deglaciation”

## Brief History of Orbital Theory of the Ice Age Cycles

- Agassiz (1840)
  - Summarized geologic evidence for an ice age
- Adhemar (1842)
  - First to attribute an ice age to orbital changes of Earth around Sun
  - Highlighted precession and # of hours of daylight
- Croll (1864)
  - Postulated *less* winter insolation was key to having an ice age: high eccentricity & winter hemisphere near aphelion (farthest from sun) promoted ice accumulation
  - Theory was dropped when prediction of timing of glacial conditions didn't match evidence
- Milankovitch (1911)

## Milankovitch (1911)

- Koppen suggested to M. that summer insolation was the key to the ice ages
  - Winter: too cold to get much accumulation
  - Summer: low-insolation summers produce less melt in Fall and Spring, allowing winter snow to persist.
- M. calculated summer insolation at 65N vs time
- At the time, proxy data did not support predicted timing of glacial vs interglacial conditions
- New data from ocean sediment cores (and new data methods) clearly showed the ice ages went in cycles, and matched pretty well with summer insolation at 65N

## Reasons for Glacial Cycling

- Changes in solar input in the NH summer drive the ice age cycles (Kopen, Milankovitch)
  - Reduced summer insolation would mean less winter snow melt → would eventually grow ice sheets
  - Increased summer insolation → more snow melt → easier to shrink ice sheets
  - N. Hem. matters more b/c there's more land there
- Albedo and CO<sub>2</sub>/methane are positive feedbacks
  - Play important role in setting amplitude of changes

## Orbital Theory: Trigger and Feedback Mechanism

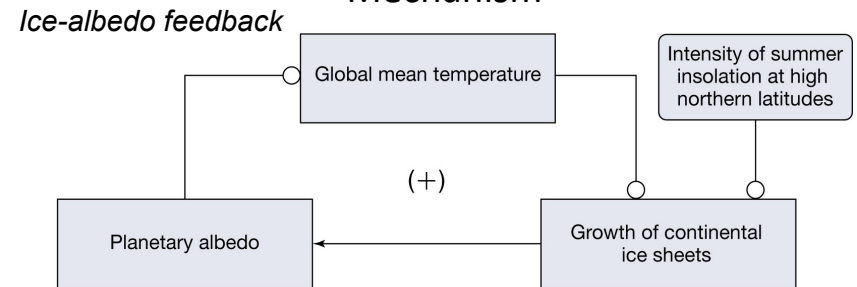

Trigger (change in insolation) with feedback causes ice-sheets...  
to grow and keep growing

OR

to melt and keep melting

- Other feedbacks are needed to explain the magnitude of the changes.
- Greenhouse gases (e.g. CO<sub>2</sub> and CH<sub>4</sub>) seem to be involved.

## Ice Albedo Feedback

- Probably important for the climate changes in the northern hemisphere during ice age cycles
  - Ice sheets that extend far south into the northern midlatitudes reflect significant sunlight (change the planetary albedo from 0.30 today to 0.32 at the LGM)
- Contrary to popular belief, *ice-albedo* feedback is not important for understanding how climate will change over the next millennium due to increasing greenhouse gases

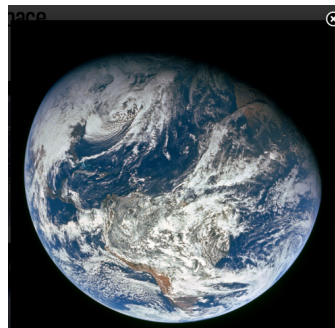

## Orbital Variations and Insolation Obliquity or Tilt

- Tilt angle is presently 23.44°
- Tilt is the main reason why we have large seasonal cycles in mid-latitudes and polar regions
- Variations in tilt angle have no impact on global *average* insolation

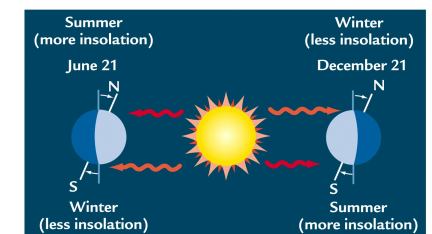
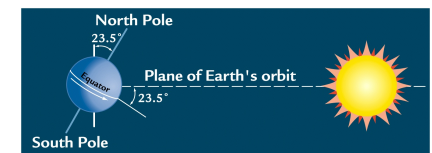

## Orbital Variations and Insolation

### Obliquity or Tilt

- Tilt of axis of rotation varies from 22.5° and 24.5°
  - Dominant period of 41 kyr
- Variations in tilt angle modulate seasonality, especially in high latitudes
  - Winter & summer insolation anticorrelated (good for Milankovitch's theory)
  - Impacts annual mean insolation at a given latitude
- To fix ideas: in NH high latitudes, less tilt means less summer insolation, more winter insolation and less annual averaged insolation (favors glaciation)
- Variations in tilt angle have no impact on *global* average insolation

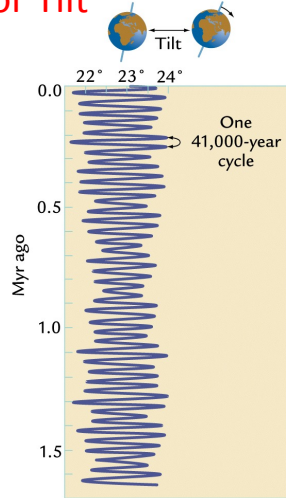

## Orbital Variations and Insolation

### Eccentricity

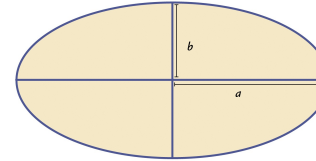

$$\text{Eccentricity } e = \frac{(a^2 - b^2)^{1/2}}{a}$$

- Eccentricity
  - $e = (a^2 + b^2)^{1/2} / a$
- e varies from 0.000 to 0.067 (currently 0.017) with four periods ranging from 95-131 kyr (100kyr) to 413 kyr
- Slight change in global, annual average insolation (0.18%, or 5 Wm<sup>-2</sup>)

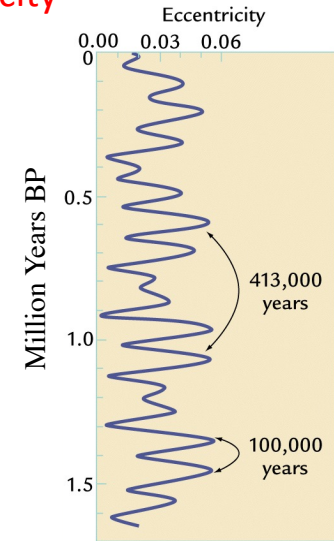

## Orbital Variations and Insolation:

### Precession

- Precession of Equinoxes is due to:
  - Wobble of Earth's axis of rotation around a line perpendicular to the Earth-Sun plane (21-26kyr)
  - Affects which calendar day the Earth is closest/farthest from the Sun
- Modulates amplitude of seasonality at all latitudes, especially in the tropics*
- No effect on the annual mean insolation (anywhere)

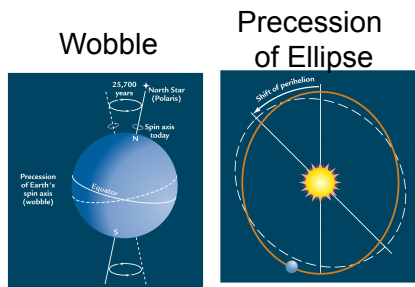
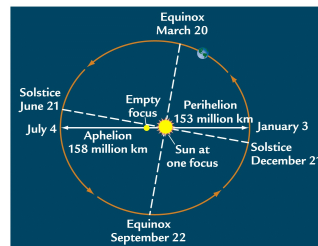

## Orbital Variations and Insolation

### Tropics vs. High latitudes

- In the tropics, seasonal insolation changes are predominately due to changes in precession (23kyr)
- In the high latitudes, seasonal changes in insolation are due to both tilt (41kyr) and precessional (23kyr) changes

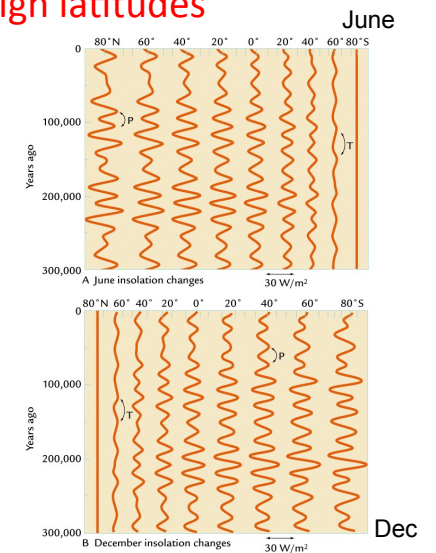

## Orbital Variations and Insolation: Phasing of Hemispheric Insolation

- Tilt changes cause changes in summer insolation that are in phase between the hemispheres. Ditto for winter.
- Precession changes cause changes in summer insolation that are out of phase between hemispheres. Ditto for winter

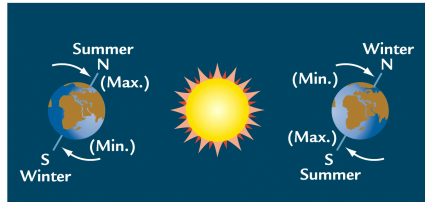

A Tilt

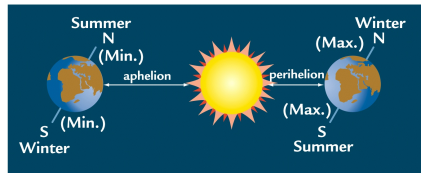

B Precession

## Summary: orbital changes on insolation

- Amplitude of the seasonal cycle of TOA insolation:
  - For reference, today the seasonal cycle is +/- 150Wm<sup>-2</sup> in the midlatitudes, and +/-15 Wm<sup>-2</sup> in the tropics
  - The net effect of orbital changes on *seasonal* insolation is ~ +/- 30 Wm<sup>-2</sup> in the midlatitudes and in the tropics.
  - Precession (23kyr) dominates in the tropics; Precession and tilt (41kyr) affect the high latitudes.
- *Within a hemisphere: tilt and precession cause insolation changes in summer that are out of phase with those in winter (double whammy on ice volume).*
  - Hemispheric Synchronicity:
    - Tilt causes changes in summer insolation that are in phase between hemispheres. Ditto for winter.
    - Precession causes changes in summer insolation that are out of phase between hemispheres. Ditto for winter.
- Only eccentricity can change the global, annual average insolation (by about .18%, or 5 Wm<sup>-2</sup>).

## Tool: Correlation Coefficient (r)...

a measure of the goodness of a linear fit between two variables

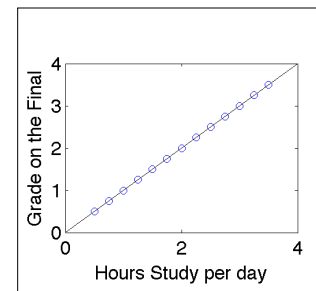

$r = 1$  is a perfect fit

## Tool: Correlation Coefficient (r)...

a measure of the goodness of a linear fit between two variables

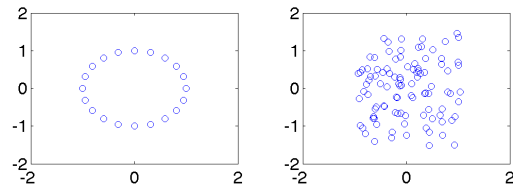
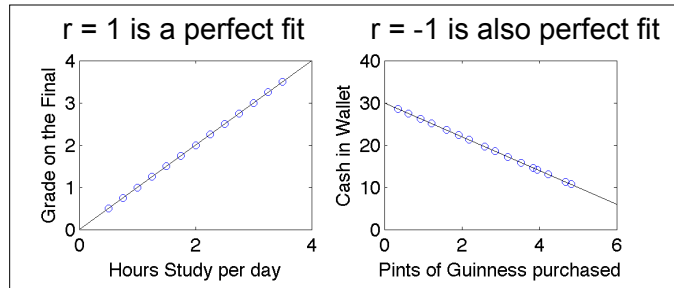

$r = 0$  means there is no (linear) relationship between the variables

## Tool: Correlation Coefficient (r)...

a measure of the goodness of a linear fit between two variables

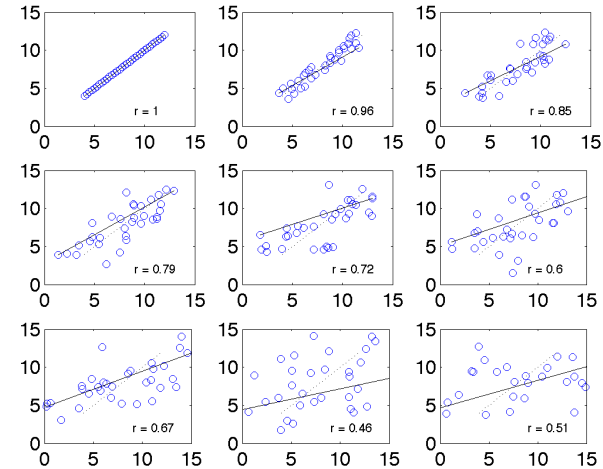

$|r| = 0.7$  is an ok fit

## The ice volume time series

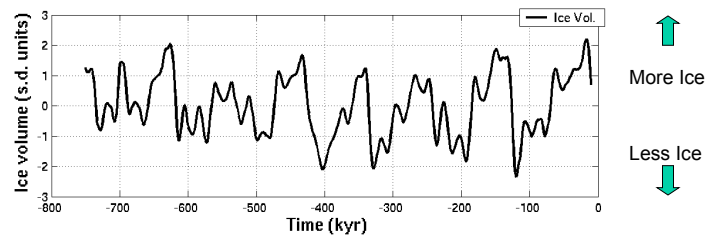

- the fraction of  $^{18}\text{O}$  to  $^{16}\text{O}$  in the shells of organisms preserved in deep sea sediment cores is proportional to ice volume

- Composite stack from ~ 20 sediment cores

Imbrie et al., 1984

## Ice Sheet Growth versus High Latitude Solar

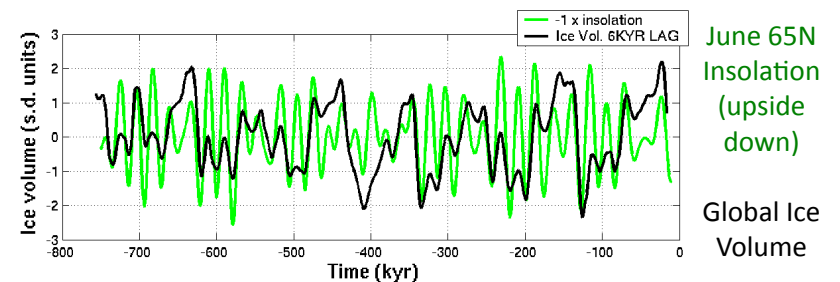

- maximum correlation of **-0.4**  
with a **6 kyr lag of ice volume behind insolation**  
(e.g., low insolation is followed by increased ice)

- more ~100 kyr variability in ice volume than in insolation

Roe 2005

## Tool: Correlation Coefficient (r)...

a measure of the goodness of a linear fit between two variables

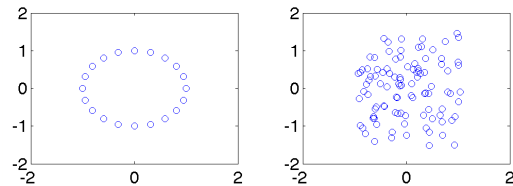
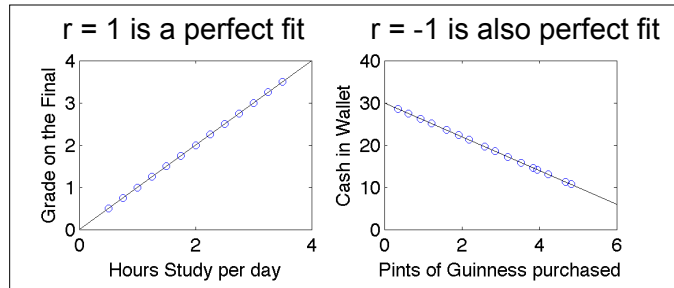

$r = 0$  means there is no (linear) relationship between the variables

## Tool: Correlation Coefficient (r)...

a measure of the goodness of a linear fit between two variables

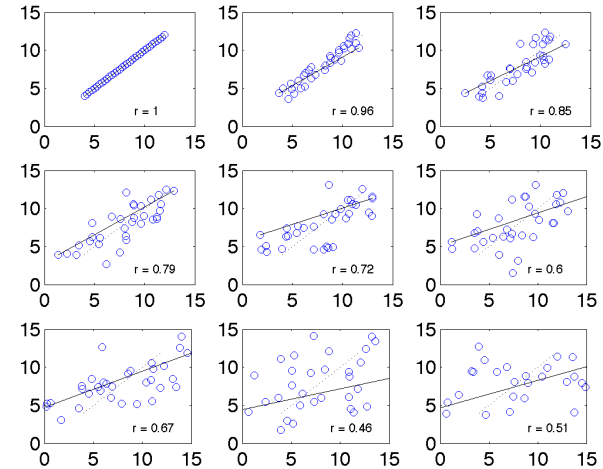

$|r| = 0.7$  is an ok fit

## The ice volume time series

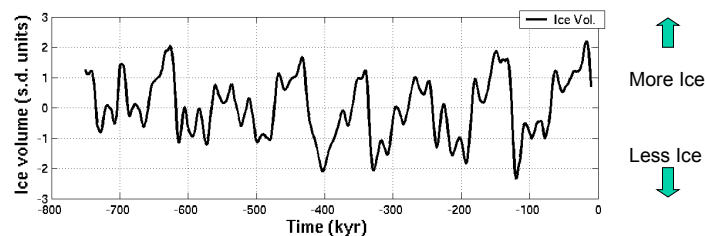

## Ice Sheet Growth versus High Latitude Solar

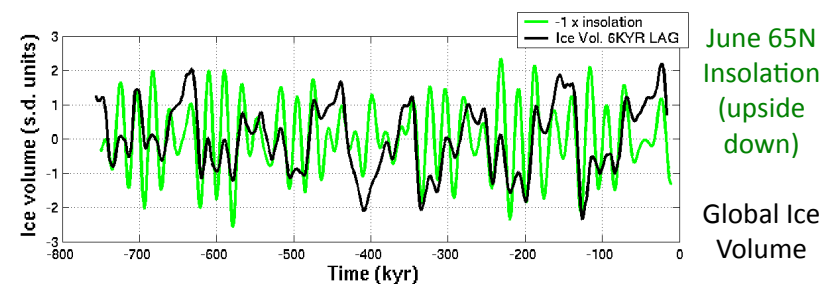

- the fraction of  $^{18}\text{O}$  to  $^{16}\text{O}$  in the shells of organisms preserved in deep sea sediment cores is proportional to ice volume

- Composite stack from ~ 20 sediment cores

Imbrie et al., 1984

- maximum correlation of **-0.4**  
with a **6 kyr lag of ice volume behind insolation**  
(e.g., low insolation is followed by increased ice)

- more ~100 kyr variability in ice volume than in insolation

Roe 2005

## Ice Sheet Growth versus High Latitude Solar

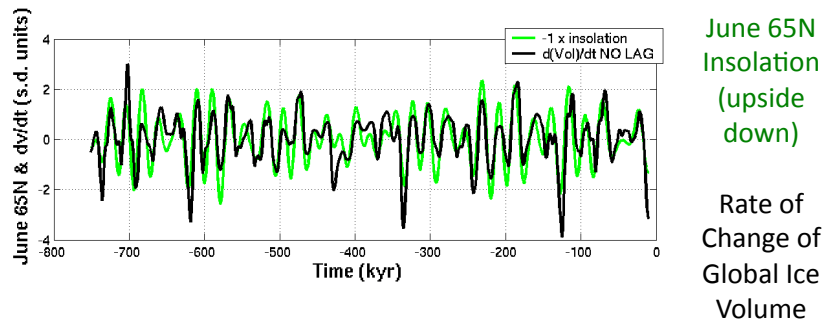

- Rate of change of ice volume is more directly related to high latitude NH summer insolation:

Correlation of -0.8 (at zero lag)

Roe 2005

## Rate of change of ice volume

- Rate of change of ice volume more directly related to high latitude insolation

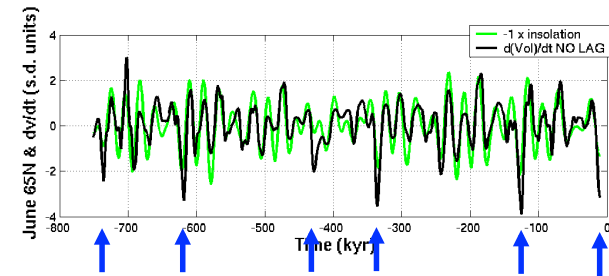

- Terminations coincide with insolation maxima - points to insolation trigger
- Major difference is large negative rates of ice change during major deglaciations

## What do climate models say?

- Run a climate model (more later) using modern day forcing:
  - 360 ppm CO<sub>2</sub>, today's insolation, today's land ice distribution, etc.
- Run a climate model using forcing associated with the Last Glacial Maximum (about 23 kyr ago):
  - 200 ppm CO<sub>2</sub>, insolation and land ice distribution for 23kyr BP, etc.
- Take the difference (annual averaged over many years)

## Surface Air Temperature: LGM minus Today

**One Climate Model**  
Broccoli 2000

TABLE 2. Annually averaged surface air temperature difference (K)

	Global	Northern Hemisphere	Southern Hemisphere
Land and ocean	-4.0	-5.9	-2.1
Land only	-6.4	-7.0	-3.4
Ocean only	-2.7	-4.1	-1.8

**Second Climate Model**

Hewitt & Mitchell 1997

		Globe	N.Hemis	S.Hemis
Total	(simulated)	-4.4	-6.5	-2.3
Topography and surface albedo	(simulated)	-3.0	-5.0	-1.1
CO <sub>2</sub>	(estimated)	-1.4	-1.6	-1.2
Insolation	(simulated)	-0.1	0.1	-0.2
Total of rows 2, 3, 4		-4.5	-6.5	-2.5

## Ice Age Cycles: Some big solved problems

- Current climate is not the only possible one for Earth
  - indeed, glacial conditions seem to be preferred for the past 2.7Myr
- The ice Age Cycles wax and wane due to changes in the way the Earth orbits the sun
  - Global climate and CO<sub>2</sub> are intimately intertwined, but CO<sub>2</sub> is acting as a feedback and not the driver of ice age cycles
- A change in global-mean surface temperature of about 4-5°C is a massive climate shift
- If the orbital parameter theory is right, small triggers can produce major climate changes under some conditions

## The Ice Age Cycles: Some big unsolved questions

- Why is CO<sub>2</sub> so highly correlated with ice volume?
  - Simple but incomplete answer: colder water can “hold” more CO<sub>2</sub>
- Are changes in CO<sub>2</sub> important for the ice ages?
  - They provide a weak positive feedback in the NH
  - What about the SH? Temperature at Vostok is ~ in sync with NH ice volume. But is ice volume in the southern hemisphere correlated with ice volume in the northern hemisphere throughout the ice ages? Unknown
- What causes the major deglaciations?
  - Much more ice is lost in the terminations of an ice age than would be expected by simple increases in summer insolation.
  - Answer: ideas are on the table, but the jury is still out

## The Ice Age Cycles: Some big unsolved questions

- Why is CO<sub>2</sub> so highly correlated with ice volume?

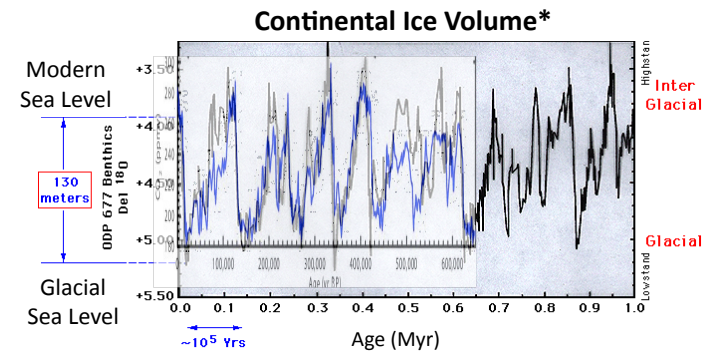

\*Oxygen Isotope composition of benthic organisms preserved in ocean sediment cores

## Abrupt Climate Change during the Last Glacial Period

During Glacial stages, the climate system featured large rapid rearrangements.

Dansgaard/Oeschger (D/O) events show:

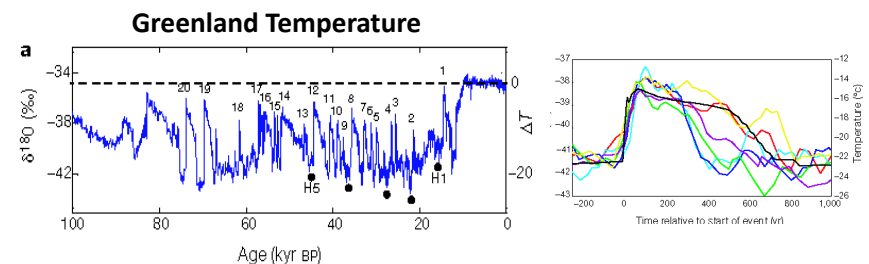

- Rapid onset of warming at Greenland ( 10°C in < 10 years!)
- Long-lived (~ 200 - 600 years) warm period, followed by slow decline back to cold conditions

## What happens to climate when you have abrupt change in sea ice in the N. Atlantic?

- About 30 of these *abrupt* climate change events happened during the last ice age (one every ~1500 yrs)
- About two dozen are abrupt *warmings* due to abrupt removal of sea ice in the N. Atlantic
  - Sea ice usually extends south to about Maine/England in a glacial period
  - The abrupt warming is due to sea ice retreating northward into the Nordic Seas
- Five abrupt *coolings* also happened due to massive discharges from the Ice Sheet over N. America and Canada
  - Sea ice abruptly expands to cover most of the North Atlantic

## Winter climate response to an abrupt increase in sea ice during the last glacial period

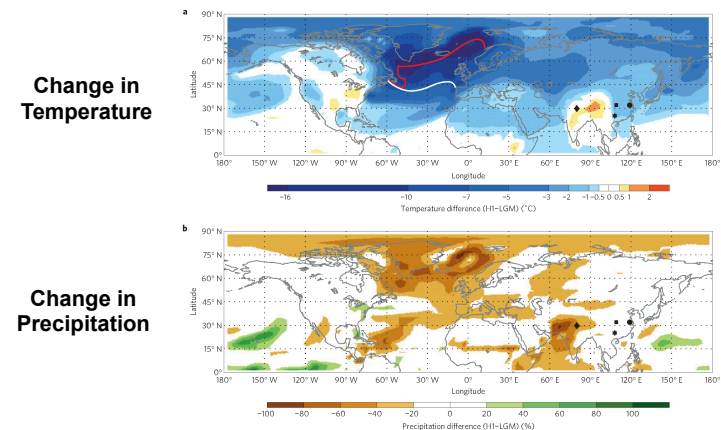
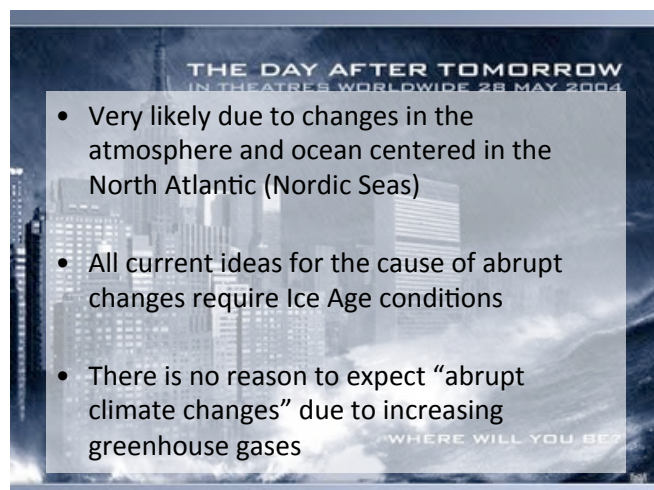

Figure 1 | Annual averaged temperature and precipitation difference between the H1 and LGM. a, Surface temperature difference (°C). b, Precipitation difference (%). Markers indicate the locations of the following caves: Hulu (circle), Songjia (square), Dongge (star) and Timba (diamond). The lines in a indicate the annual climatological 50% sea-ice extent for H1 (white) and LGM (red) in the North Atlantic sector.

Pausata et al 2010

## Abrupt Climate Change during the Last Glacial Period



<http://www.youtube.com/watch?v=SnvqsWVluCE>

## Abrupt Climate Change during the Last Glacial Period

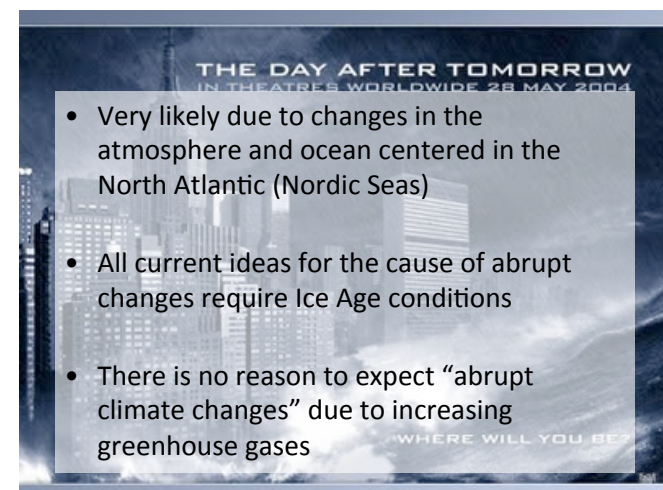

# Trends in 20<sup>th</sup> Century Climate

- Material taken from the most recent IPCC report
  - Found here: [www.ipcc.ch](http://www.ipcc.ch) (click on “Publications and Data”)
  - What is the IPCC?
- Global Trends
- Regional Trends
- Pacific Northwest
- Summary

Readings: 4<sup>th</sup> Assessment of Climate Change by the IPCC; Chapter 3 and the executive Summaries of Chapters 4 and 5 in the Working Group 1 Report.  
[www.ipcc.ch/publications\\_and\\_data/ar4/wg1/en/contents.html](http://www.ipcc.ch/publications_and_data/ar4/wg1/en/contents.html)

## What is the IPCC?

- WHAT?
  - A scientific intergovernmental body set up by the World Meteorological Organization (WMO) and by the United Nations Environment Programme (UNEP)
- WHO?
  - Thousands of scientists all over the world contribute to the work of the IPCC as authors, contributors and reviewers
  - Governments participate in plenary Sessions of the IPCC where main decisions about the IPCC work program are taken and reports are accepted, adopted and approved. They also participate in the review of IPCC Reports.

[www.ipcc.ch/about/index.htm](http://www.ipcc.ch/about/index.htm)

- Mandate of the IPCC
  - to provide the decision-makers and others interested in climate change with an objective source of information about climate change.
  - to assess on a comprehensive, objective, open and transparent basis the latest scientific, technical and socio-economic literature produced worldwide relevant to the understanding of the risk of human-induced climate change, its observed and projected impacts and options for adaptation and mitigation.
- The IPCC does not conduct any research nor does it monitor climate related data or parameters
- IPCC reports
  - must be of high scientific and technical standards, and aim to reflect a range of views, expertise and wide geographical coverage.
  - must be neutral with respect to policy, although they need to deal objectively with policy relevant scientific, technical and socio economic factors.

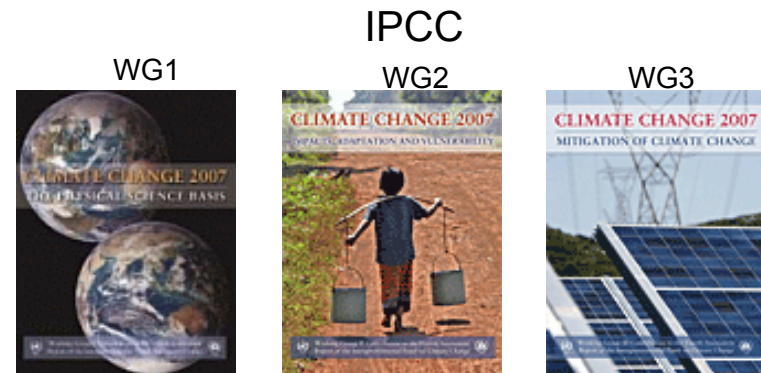

- Regular Assessments mandated by governments (UN) 1990, 1995, 2001, 2007, 2014 ...
- Summarize state of climate science\* (WG1), impact of climate change (WG2), and possible mitigation options (WG3)

\* Must be published in the peer-reviewed literature

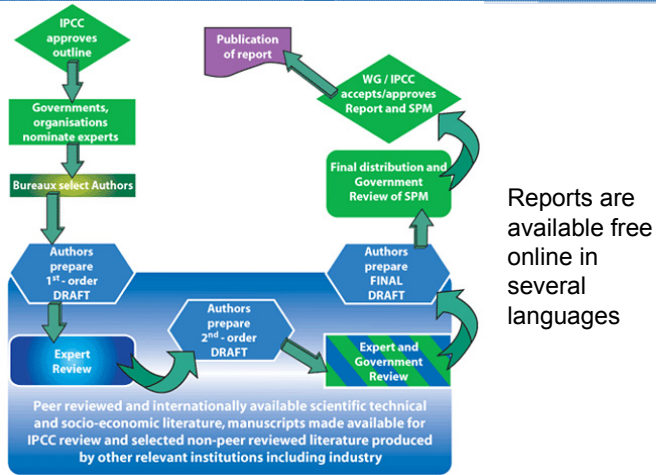

A typical IPCC report takes ~ five years to produce and involves ~2700 scientists



# Trends in 20<sup>th</sup> Century Climate

- Material taken from the most recent IPCC report
  - What is the IPCC?
- Global Trends
- Regional Trends
- Pacific Northwest
- Summary

## Increasing surface temperature: vocabulary

"Global-Annual Average Surface Temperature (GAAST)"  
 primarily index of change (although not what we really care about)

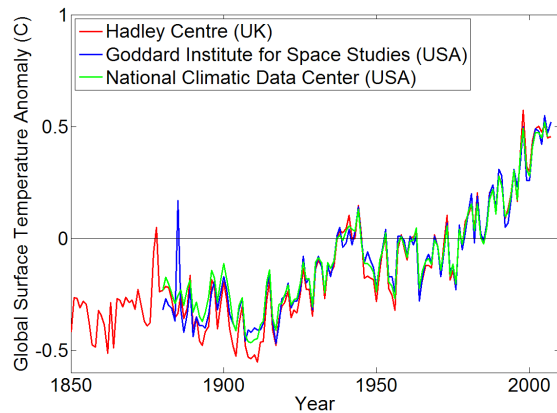

"Temperature Anomaly" change with respect to some reference period (here 1961-1990)

"How accurate is the surface temperature record?"

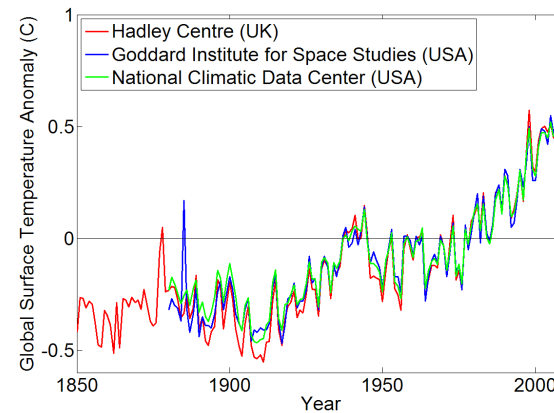

### Quantifying Uncertainty

- key aspect of scientific method, knowledge
- Often difficult to do

### One (partial) approach:

- independent groups analyzing the ~same data set

# Global Annual Average Temperature

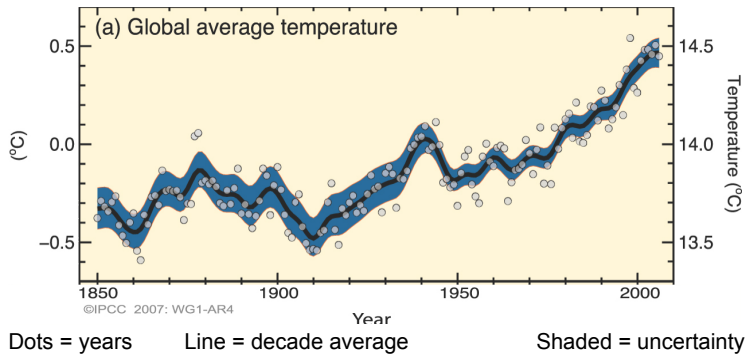

- The global annual averaged surface temperature has risen about 0.85°C (1.5°F) in the past 100 years
- The past decade is the warmest in the instrumental record

IPCC Fig SPM3

# The warming trend is accelerating

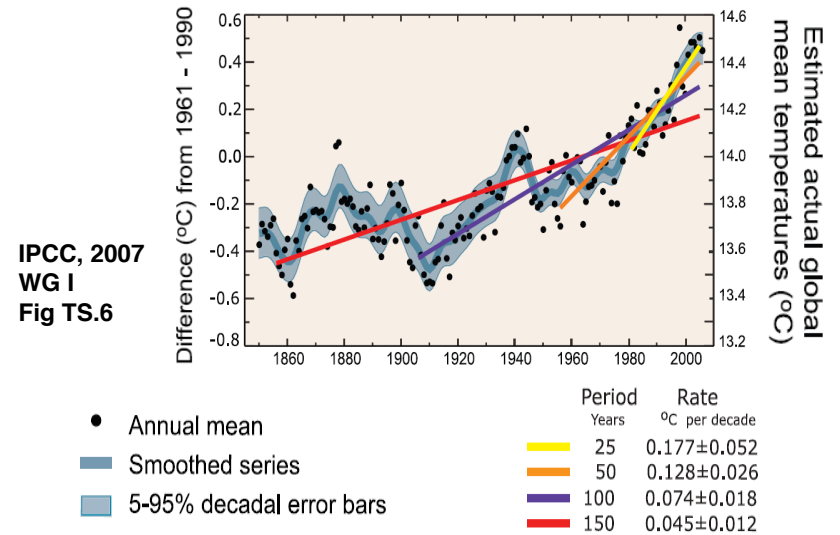

## Is the warming "Global"?

IPCC, 2007, WG I, Fig 3.9: Patterns of linear warming trends for the surface air temperature for the periods (top) 1901-2005 and (bottom) 1979-2005.

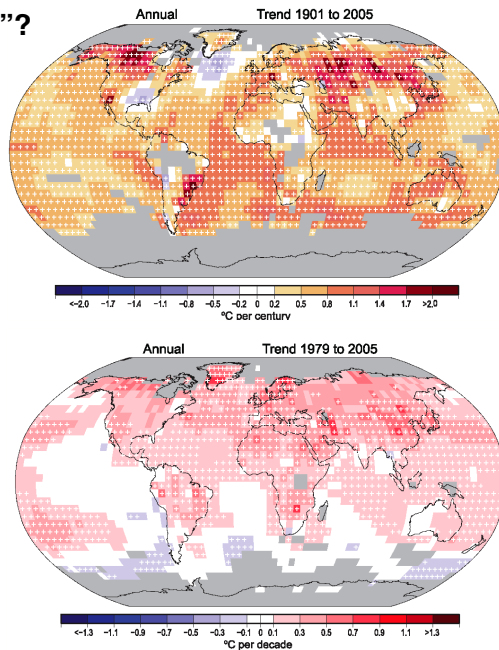

Trends significant at the 5% level are indicated by white + marks. Grey areas: not enough data to determine trend.

Yes, although enhanced over land at in northern extratropics (as expected)

## Warming extends above the surface

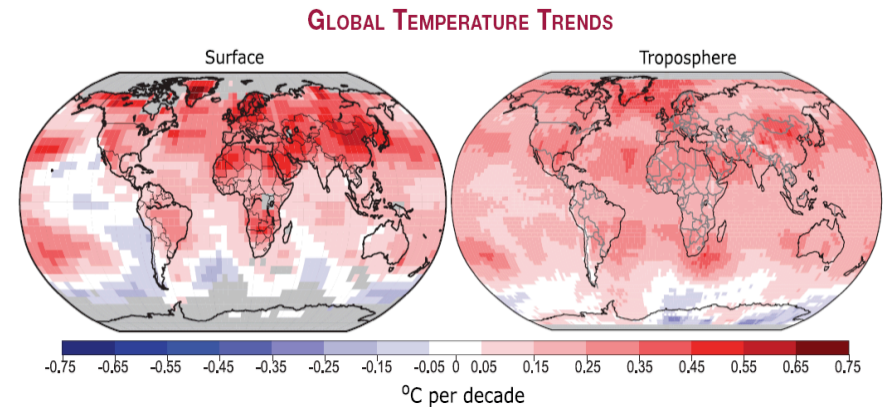

IPCC, 2007, WG I, Fig TS.6: Patterns of linear warming trends over the period 1979-2005 for the surface (left, from thermometers) and lower atmosphere (right, from satellite).

## Northern Hemisphere annual average surface temperature

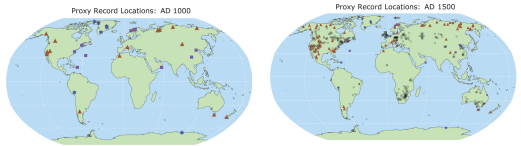
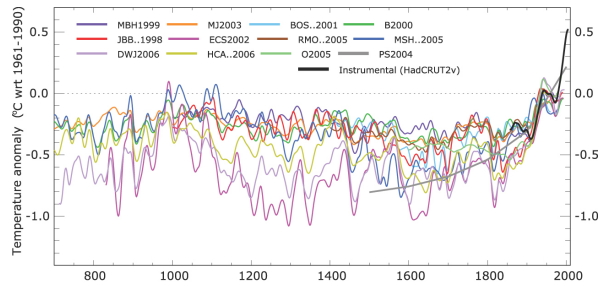

Tree rings ▲ Boreholes ● Ice cores ★ Other ■

IPCC 2007 TS.20

## Decreasing Extreme\* Cold

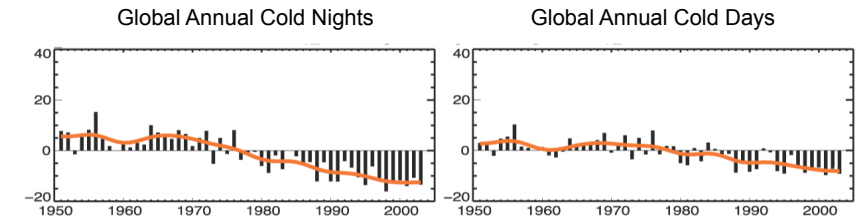
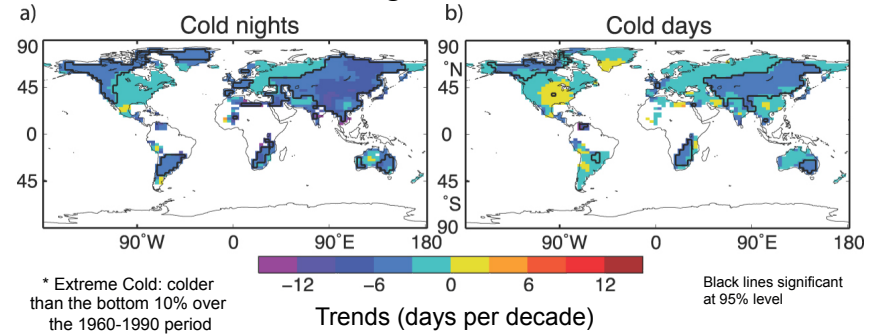

## Increasing Extreme\* Warmth

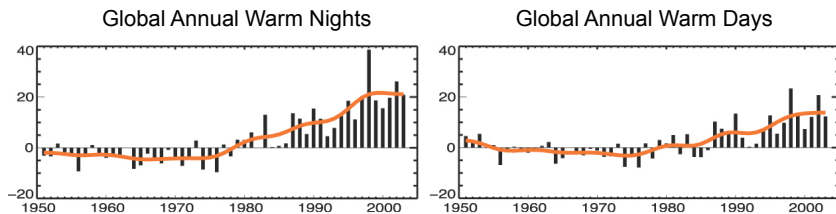
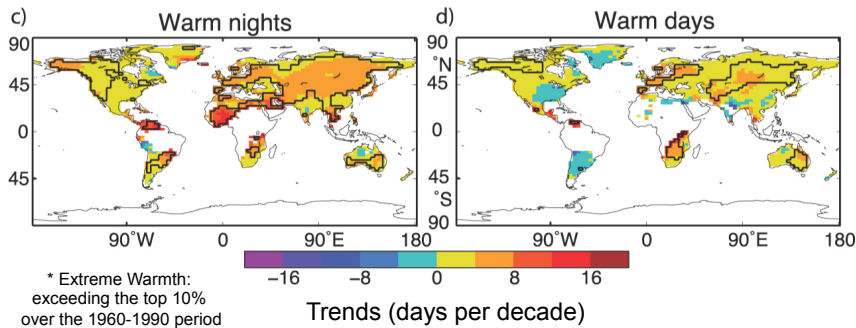

IPCC WG1 2009; FAQ 3.3, Figure 1.

## Trends in Annual Land Precipitation

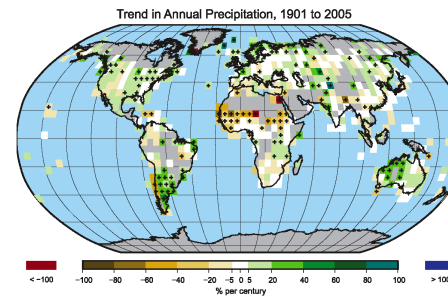

Trend for 1901 to 2005 (left, % per century) and 1979 to 2005 (bottom, % per decade). The percentage is based on the means for the 1961 to 1990 period.

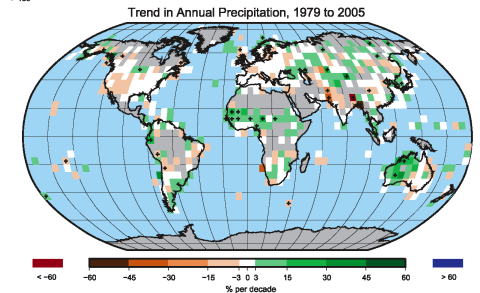

Areas in grey have insufficient data to produce reliable trends. Trends significant at the 5% level are indicated by black + marks.

IPCC WG1 2007 Figure 3.13.

## Changes in Glacier Length 1500-2000

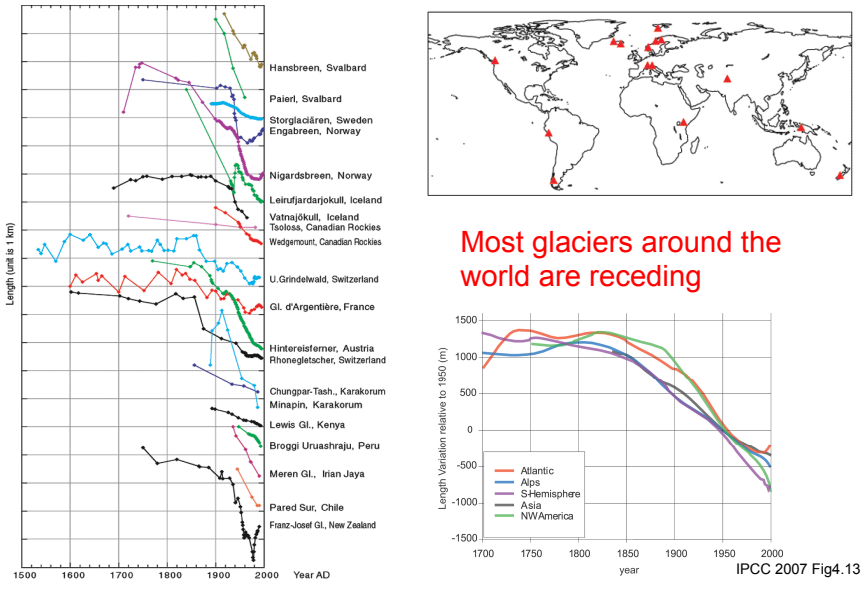

## Northern Hemisphere Snow Cover

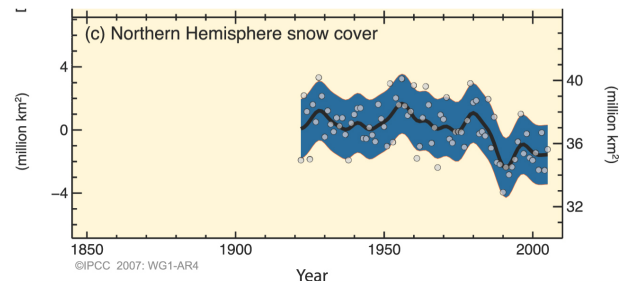

Snow cover has decreased by 7.5% since 1922.

Shaded areas show 95% uncertainty levels.  
Zero represents the 1961-1990 average.

IPCC 207 WG1 Fig SPM3

## Atmospheric Water Vapor

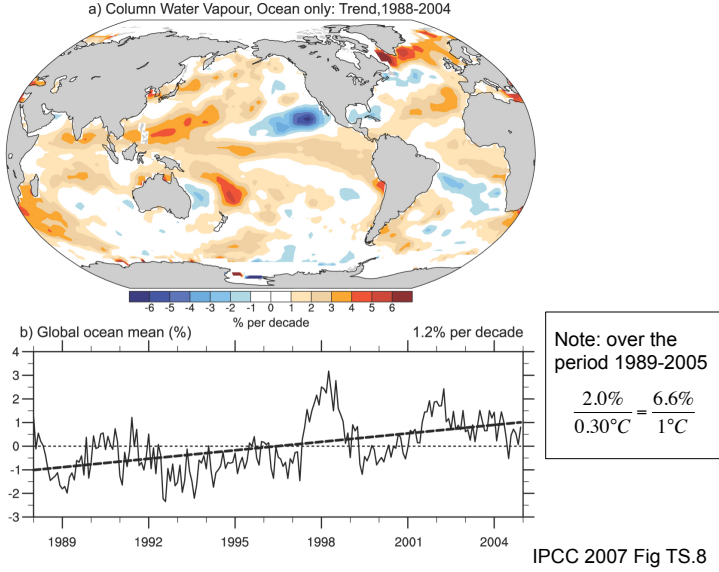

## Global Ocean Heat Content (0-700m)

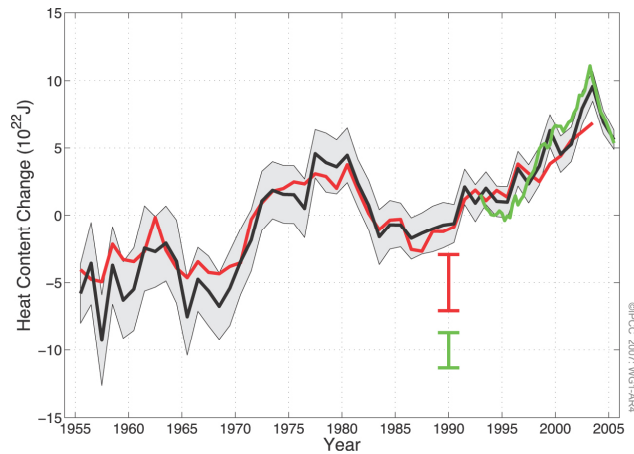

- Solid lines are three independent estimates (95% confidence interval in grey)

IPCC 2007 Fig TS.16

## Change in upper ocean temperature (1955-2003)

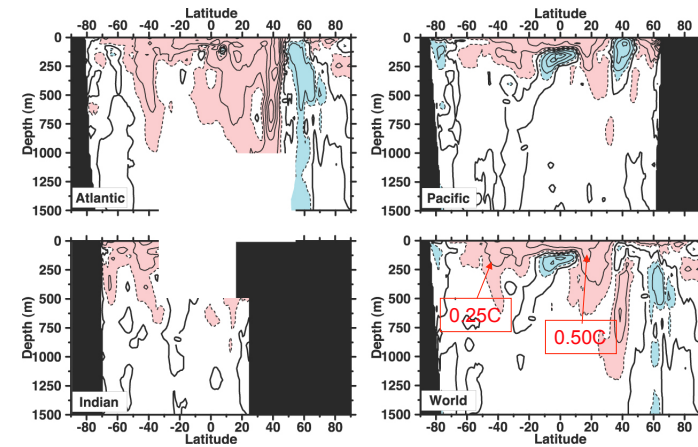

Trends in ocean temperature (averaged east-west) from 1955-2003

warming > 0.125C

cooling < 0.125C

IPCC 2007 Fig 5.3

## Global Sea Level Rise

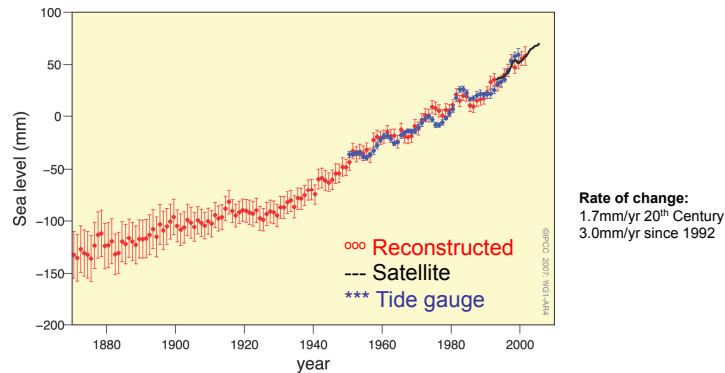

- At least half of the rise since 1960 is due to thermal expansion
- The remaining is due to melting glaciers and ice caps

IPCC 2007 Fig TS.18

## Other signs of (global) warming

- melting mountain glaciers
- rising sea level (due to warming and ice-melt)
- timing of seasonal events
  - e.g. earlier thaws, later frosts
- thinning and disappearing Arctic sea ice
- species range shifts (poleward and upward)
- earlier blossom dates for hundreds of species

## Observed changes in physical & biological systems

NAM North America  
 LA Latin America  
 EUR Europe  
 AFR Africa  
 AS Asia  
 ANZ Ausie/NZ  
 PR Polar Regions  
 TER Terrestrial  
 MFW Marine/Fresh W  
 GLO Global (All)

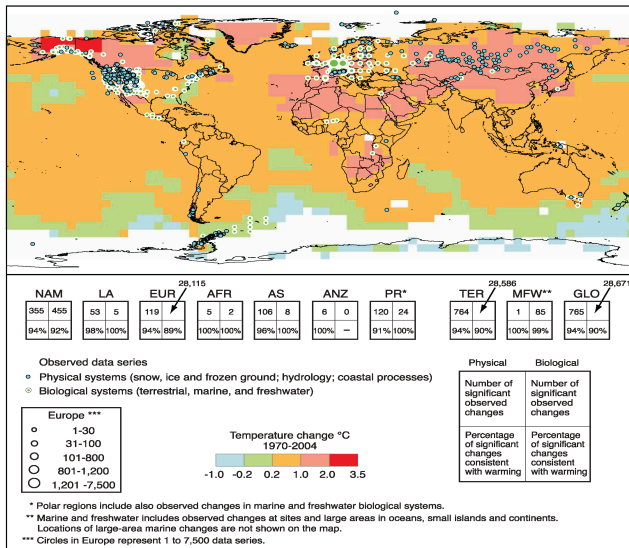

Of the changes seen in >29,000 data sets, 90% are in the direction expected as a response to warming

IPCC 2007 WG2 Fig TS.1

## Other signs of (global) warming

- melting mountain glaciers
- rising sea level (due to warming and ice-melt)
- timing of seasonal events  
 e.g. earlier thaws, later frosts
- thinning and disappearing Arctic sea ice
- species range shifts (poleward and upward)
- earlier blossom dates for hundreds of species

Every one of these data sets can be questioned. Taken together, the totality of evidence of global warming over the past Century is quite convincing.

## Trends in 20<sup>th</sup> Century Climate

- Material taken from the most recent IPCC report
  - What is the IPCC?
- Global Trends
- Regional Trends
- Pacific Northwest
- Summary

- Warming seen over all land and ocean regions
  - More in higher latitudes than in tropics; more over land than water

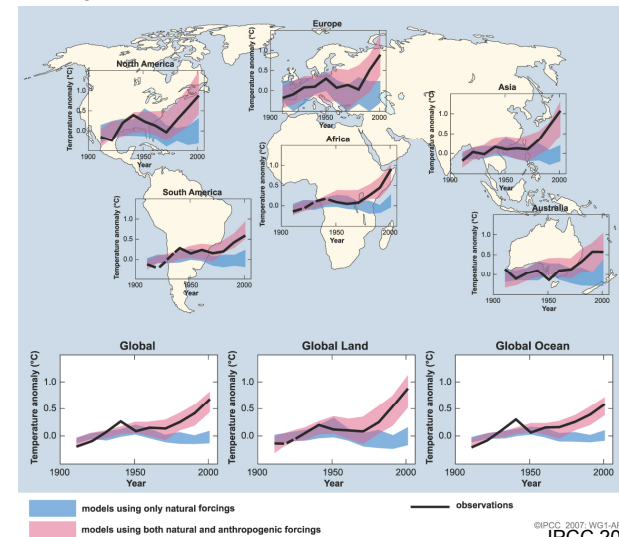

©IPCC 2007 WG1-AR4  
 IPCC 2007 Fig SPM4

## Change in Permafrost Temperatures in Alaska

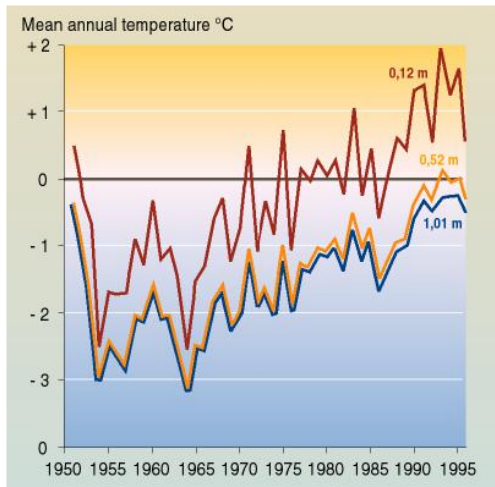

## Sea Ice Thickness

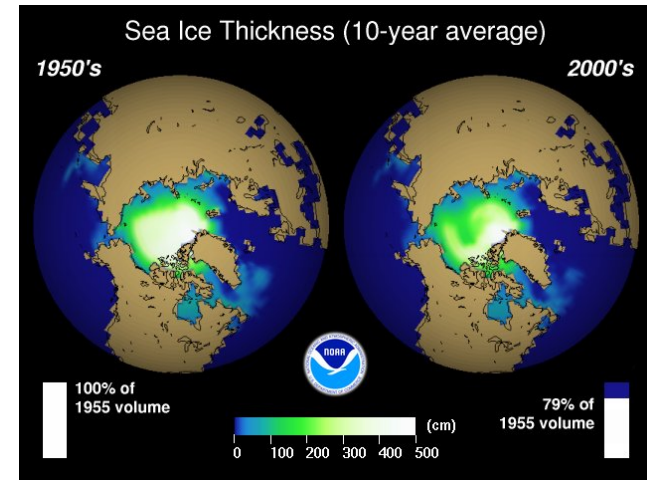

## Arctic Sea Ice Extent

Average Monthly Arctic Sea Ice Extent  
October 1979 - 2012

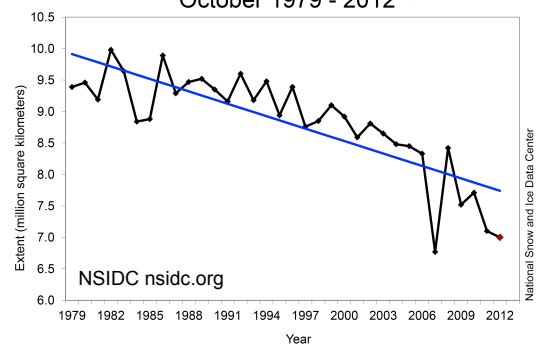

Extent of Arctic sea ice has decreased by about 25% from 1979-2012

n.b. measurements started in 1979

## Trends in 20<sup>th</sup> Century Climate

- Material taken from the most recent IPCC report
  - What is the IPCC?
- Global Trends
- Regional Trends
- Pacific Northwest
  - Temperature
  - Precipitation
  - Runoff & Stream flow
  - Snow pack
- Summary

## Puget Sound compared to Global Mean

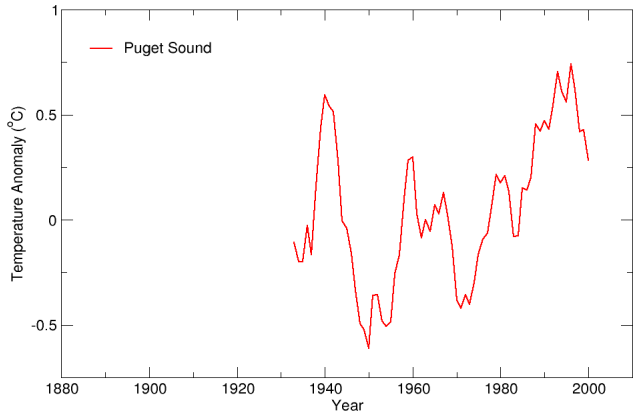

## Puget Sound compared to Global Mean

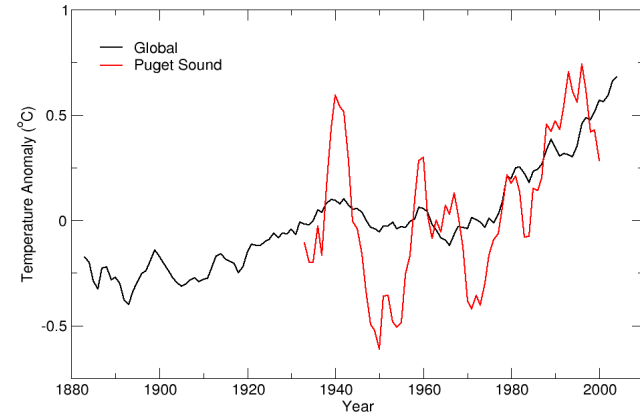

## Temperature Trends by Station

Temperature trends (°C per century), since 1920

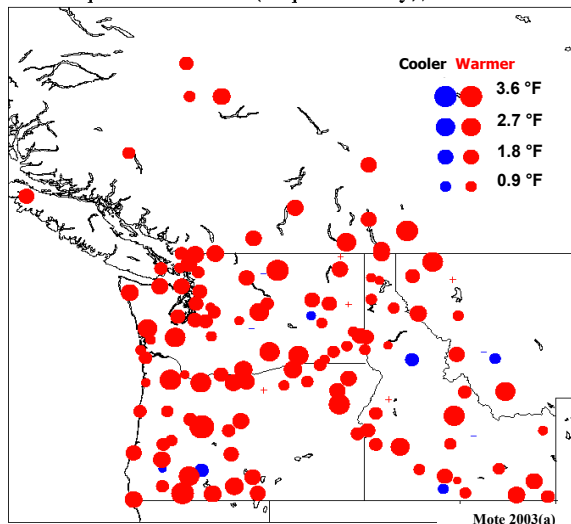

154 stations with long records

Almost every station shows **warming**

Urbanization **not** a major source of warming



## Precipitation Trends by Station

Precipitation trends, since 1920

- 165 stations with long records
- Most stations becoming wetter – **average increase of 2.9 inches (14%)...**
- ...however, it is more difficult to assess trends due to challenges in measuring precipitation

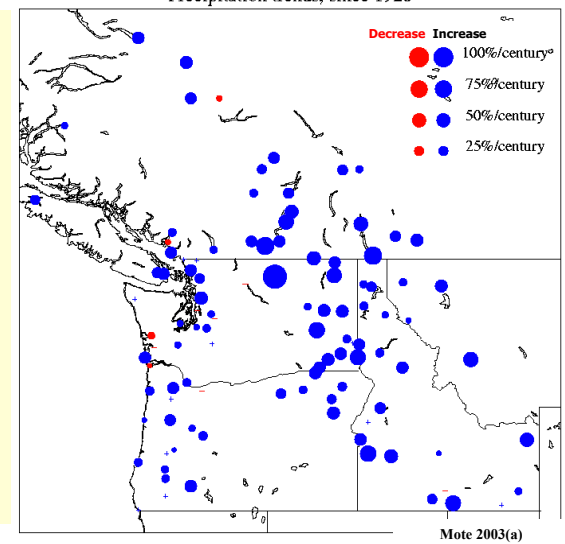

## Trends in the Timing of Spring Runoff

Peak of spring runoff is moving earlier into the spring throughout western US and Canada

- Advances of 10-30 days between 1948-2000
- Greatest trends in PNW, Canada, and AK
- >30% of trends are statistically significant at the 90% level, especially in the PNW

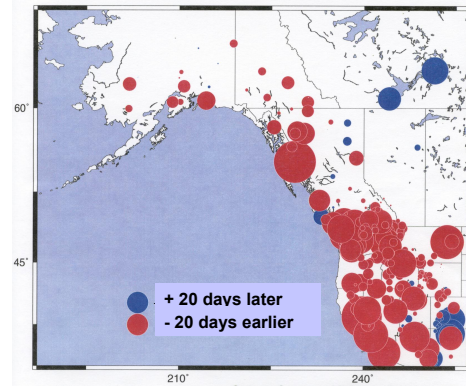

## Changes in Streamflow

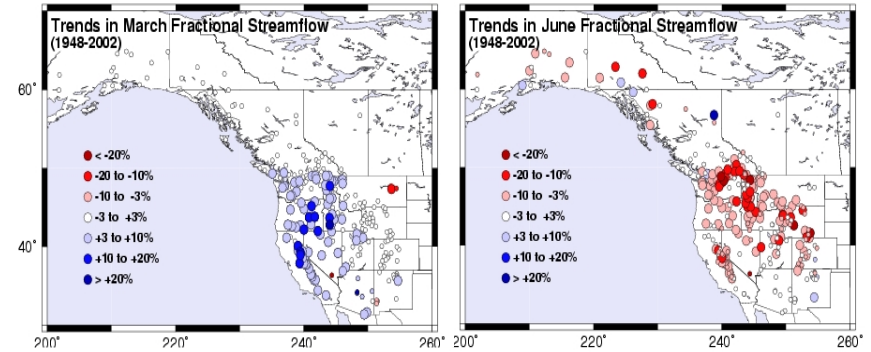

As the west warms, Spring flows increase and Summer flows drop.

Source: Cayan et al. (in review). "Changes in Snowmelt Runoff Timing in Western North America under a 'Business as Usual' Climate Change Scenario", submitted to Climate Change 3.27.03

Figure by Iris Stewart, Scripps (UCSD)

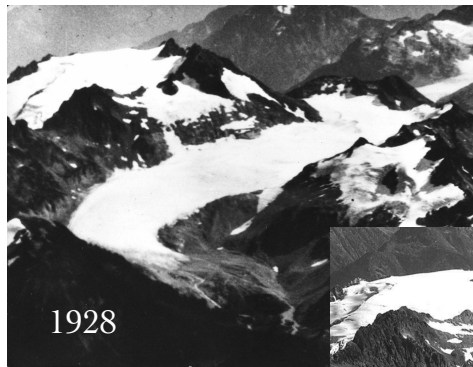

The South Cascade glacier retreated dramatically in the 20th century

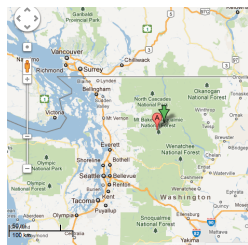
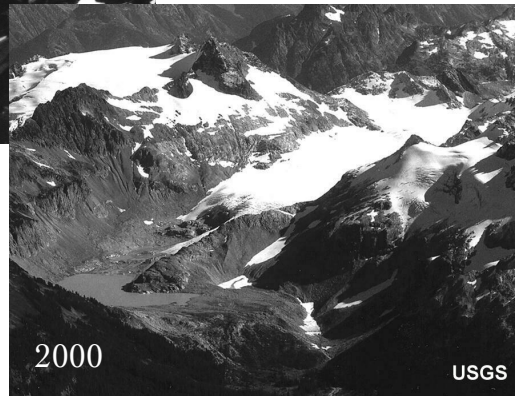

## Length of the Blue Glacier (Olympics)

About 800 meter recession since the early 1900s, and ~1500m since the early 1800s

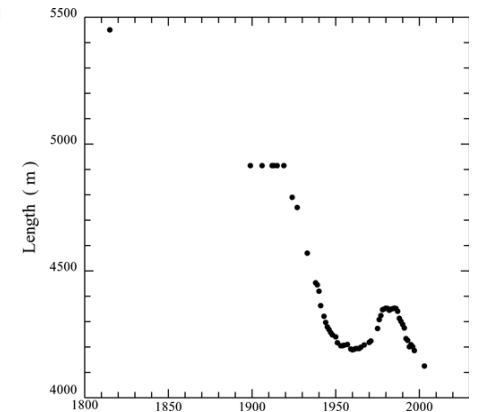

## Cascade snowpack has decreased in the last 80 years but ...

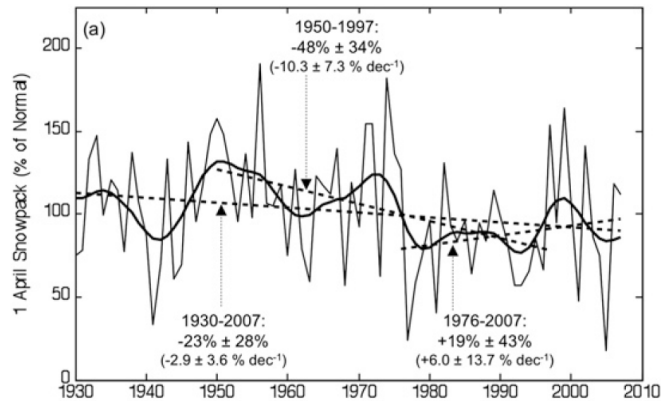

But there is a lot of natural variability so attribution is not possible (yet)

## Summary: Pacific Northwest Climate (~1920 - 2100)

- Late 20<sup>th</sup> Century Trends
  - Temperature: there has been a regional warming trend
  - Precipitation: no significant trend
  - Runoff & Stream flow: peak flows are happening earlier in Spring; Summer flows are reduced
  - Snow pack: decreased over the past 80 years

*But there is a lot of natural variability in each quantity, so attribution is not possible (yet)*
- Projections of Future Climate Changes
- Impacts of Future Climate Changes

## Trends in 20<sup>th</sup> Century Climate

### Summary

- Material taken from the most recent IPCC report
- Global Trends
  - Global, annual averaged temperature has increase ~0.85°C (1.5°F) in past 100 years
  - Warmest in NH since at least 1000 years ago (limit of data for annual records)
- Regional Trends
  - More warming over land than ocean
  - More warming in high latitudes than tropics
  - Warming at surface, aloft and in upper ocean
- Pacific Northwest
  - About 1°C warmer since 1920
  - About 15% wetter
  - Compared to 1950, Spring runoff is about 10-30 days earlier, and stream flow has increased in spring and decreased in summer

# Climate changes (1900 to 2000) due to human activity

Phenomenon <sup>a</sup> and direction of trend	Likelihood that trend occurred in late 20th century (typically post 1960)	Likelihood of a human contribution to observed trend <sup>b</sup>
Warmer and fewer cold days and nights over most land areas	<i>Very likely</i> <sup>c</sup>	<i>Likely</i> <sup>d</sup>
Warmer and more frequent hot days and nights over most land areas	<i>Very likely</i> <sup>e</sup>	<i>Likely (nights)</i> <sup>d</sup>
Warm spells/heat waves. Frequency increases over most land areas	<i>Likely</i>	<i>More likely than not</i> <sup>f</sup>
Heavy precipitation events. Frequency (or proportion of total rainfall from heavy falls) increases over most areas	<i>Likely</i>	<i>More likely than not</i> <sup>f</sup>
Area affected by droughts increases	<i>Likely</i> in many regions since 1970s	<i>More likely than not</i>
Intense tropical cyclone activity increases	<i>Likely</i> in some regions since 1970	<i>More likely than not</i> <sup>f</sup>
Increased incidence of extreme high sea level (excludes tsunamis) <sup>g</sup>	<i>Likely</i>	<i>More likely than not</i> <sup>h</sup>

HOW DO WE KNOW THIS?

Virtually certain > 99%  
 Very likely >90%  
 Likely >66%  
 More likely > 50% than not

IPCC 2007

## Climate Models

- What is a climate model?
- How long have they been around?
- How good are they?

## Climate Models

- What is a climate model?
  - Mathematical representations of the atmosphere, ocean, sea ice and land surface
  - For each component, the model is based on the laws of physics and chemistry. For example,
    - the models conserve energy, mass, momentum. They obey the laws of physics (e.g.,  $F=ma$ ) and chemistry
    - Radiation (solar and terrestrial) is based on detailed theory (quantum mechanics).
    - Concentrations of some gases are prescribed because they change very very slowly ( $N_2$ ,  $O_2$ , Ar, CFCs, etc)
    - Other gases are sometimes prescribed and sometimes calculated by the laws of chemistry and thermodynamics
  - The equations are hopelessly complicated to solve by pen and pencil (“analytically”), so we solve them numerically
  - The equations can’t be solved at a molecular level, so the climate system is chopped up regular chunks

## Climate Models

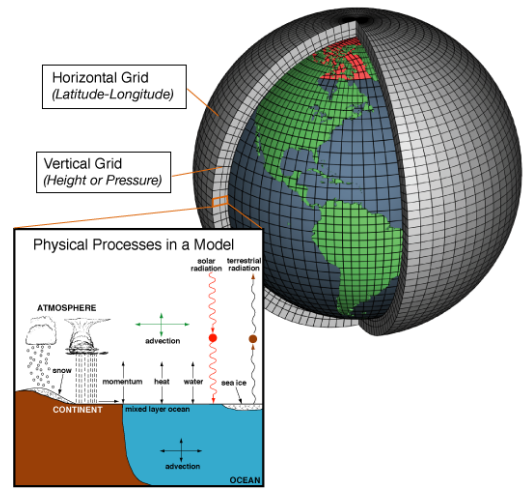

## Climate Models

- The current size of a chunk of atmosphere, land, ocean or sea ice is about 150km x 150km

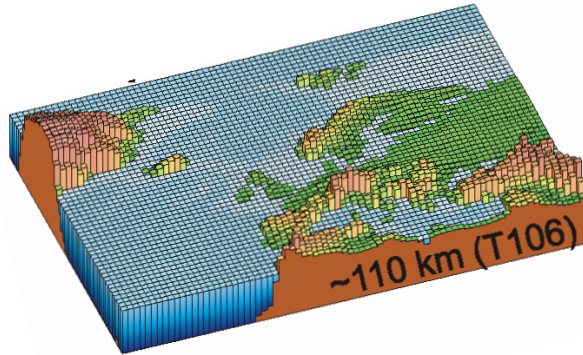

The vertical extent of a box is typically:  
 Atmosphere/Ocean: 10-500m    Sea Ice: 50cm    Land: 10cm

## Climate Models

- The physical and chemical laws are solved in each of these chunks.
  - Within each chunk, there are things that are not explicitly modelled (e.g., clouds) but must be approximated ("parameterized") as a function of the average state of the chunk (e.g, the fraction of clouds in the chunk as a function of the chunk's temperature, pressure, wind, humidity)

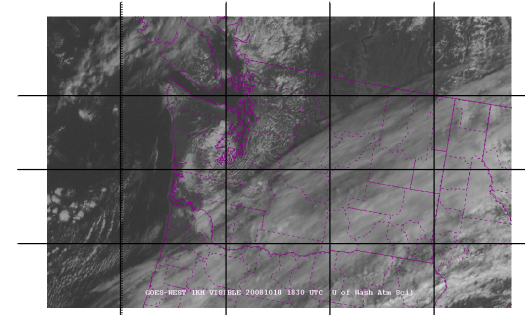

## Climate Models

- Information in one chunk affects another because of *motion*
  - Wind (atmosphere)
  - Flow (ice, rivers, groundwater movement)
  - Currents (ocean)
- Motion, in turn, is due to pressure differences that result from temperature differences
- These calculations require enormous computer resources
  - For example, a 100 year run of a typical IPCC AR4 climate model takes
    - \* Nine months on the world's fastest machines
    - \* 150,000 Gbytes of disk space (minimal output)

## Climate Models

- What is a climate model
- How long have they been around?

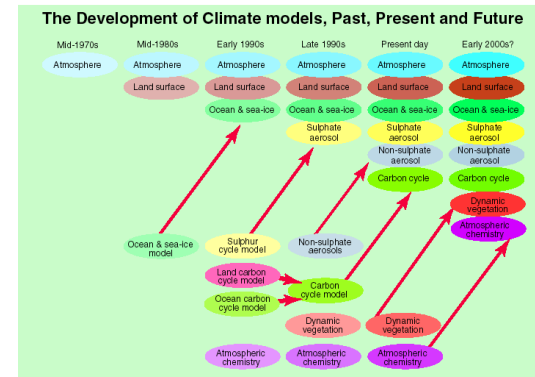

Climate Models are based on the laws of physics and chemistry, and used for ~40 years for various problems.

# Climate Models

- What is a climate model?
- How long have they been around?
- How good are they?
  - Some examples from 14 of the 23 climate models used in the most recent IPCC report: Assessment Report #4 (AR4) in 2007.

# Annual Average Surface Temperature

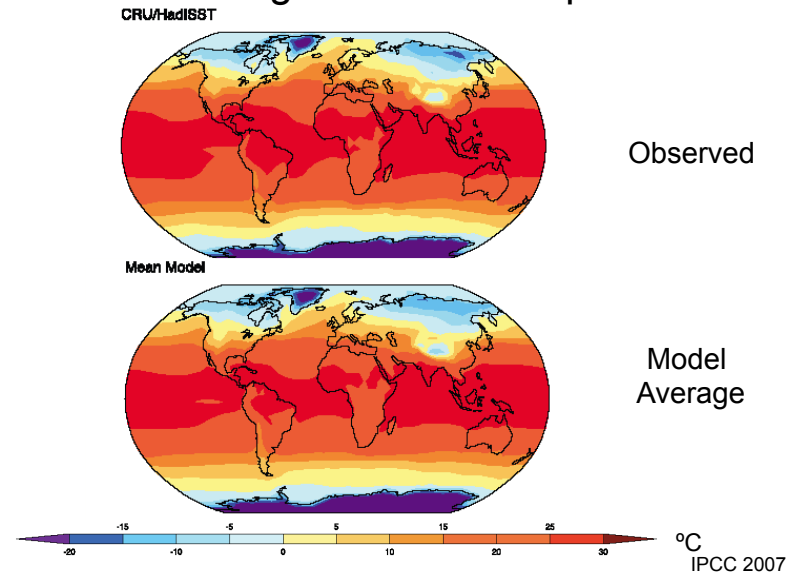

# Annual Average Surface Temperature

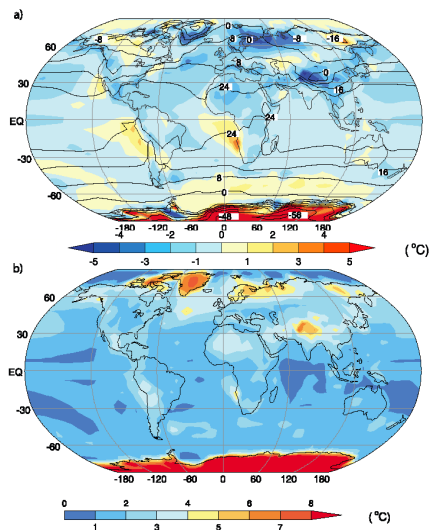

Contoured = Observed

Shaded = error in 'average of the models' (simulated minus observed)

Error in typical model

IPCC 2007

# “Annual Cycle\*” in Temperature

\* Multiply by ~3 to get approximately the difference in July and January temperature

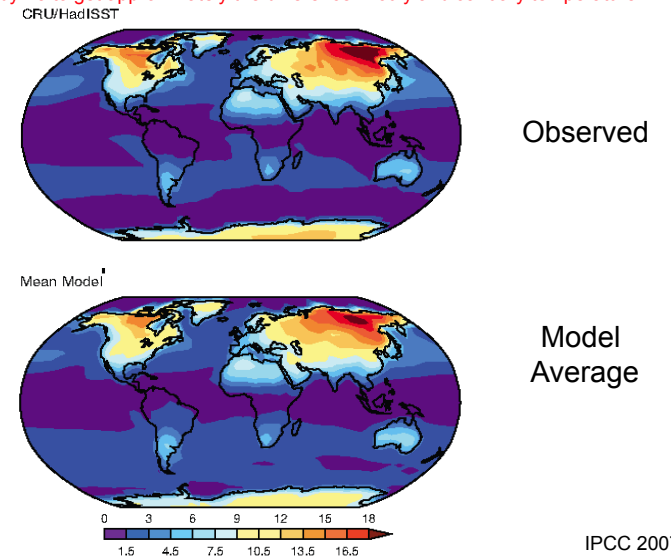

# “Annual Cycle\*” in Temperature

\* Multiply by ~3 to get approximately the difference in July and January temperature  
 CRU/HadISST

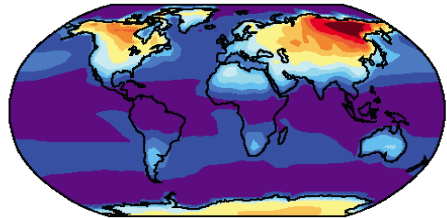

Observed

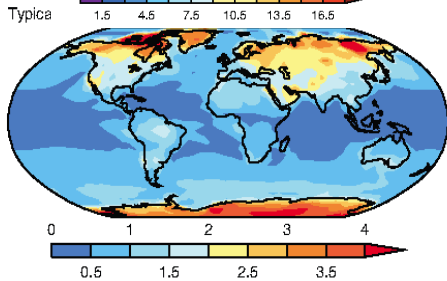

Typical Model Error

IPCC 2007

# Diurnal (day-night) temperature range

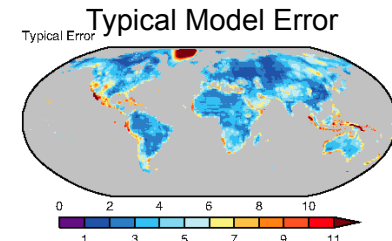
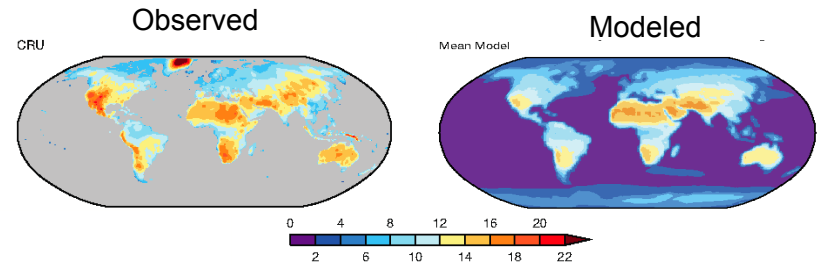

Typical Error

IPCC 2007 Fig. S8.3

# Atmospheric Temperature Zonal (east-west) average

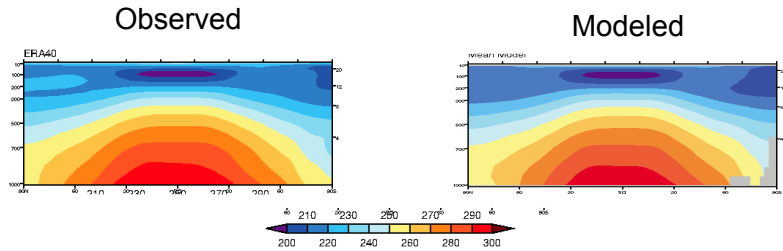

Observed

Modeled

Typical Model Error

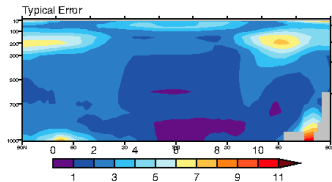

IPCC 2007

# Top of the Atmosphere Radiation Flux (averaged in the east-west direction)

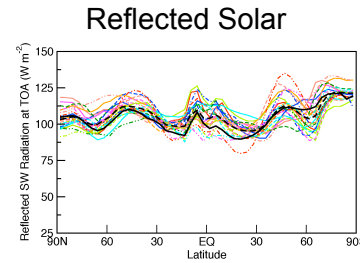

Reflected Solar

- One color line for each model
- Black dashed line for ‘average of models’

• Error

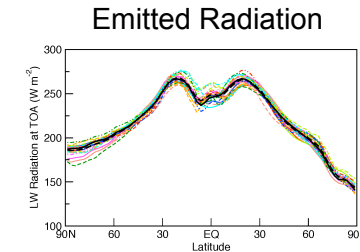

Emitted Radiation

typically 10-15 W/m<sup>2</sup>  
 (10% in reflected shortwave and 5% in emitted outgoing longwave radiation)

IPCC 2007

## Top of the Atmosphere Radiative Flux

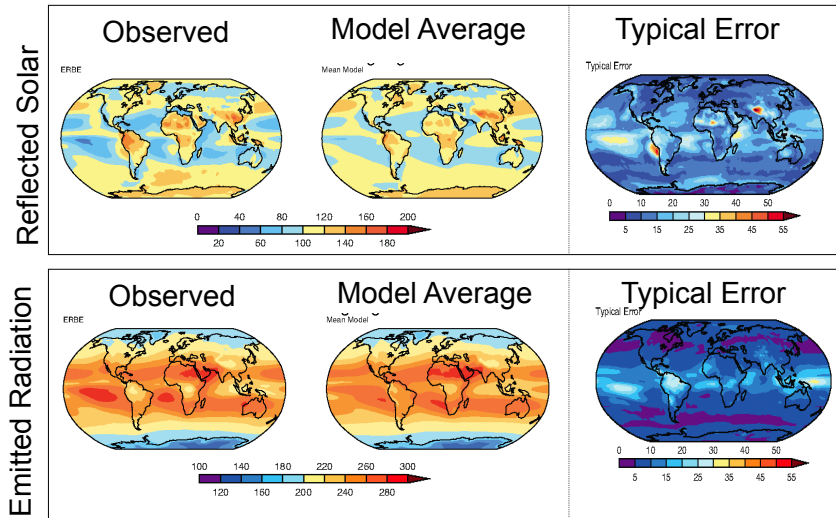

IPCC 2007

## Annual Average Precipitation

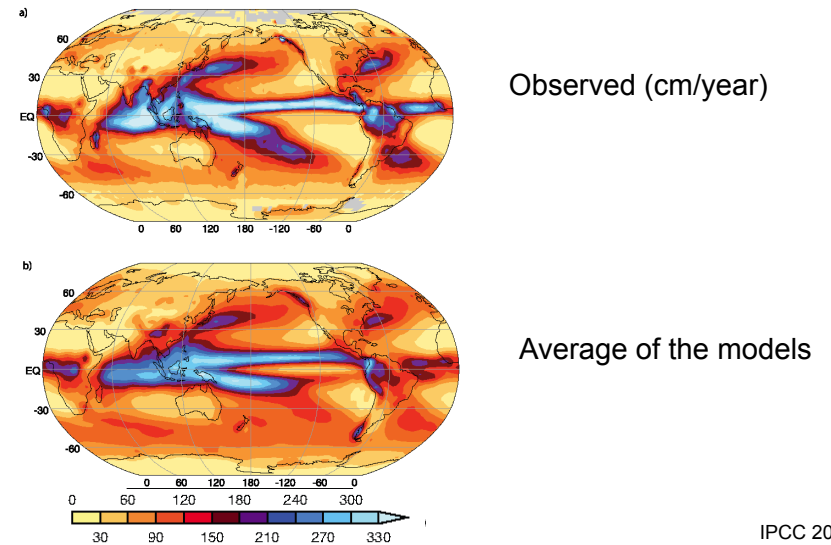

## Annual Average Precipitation

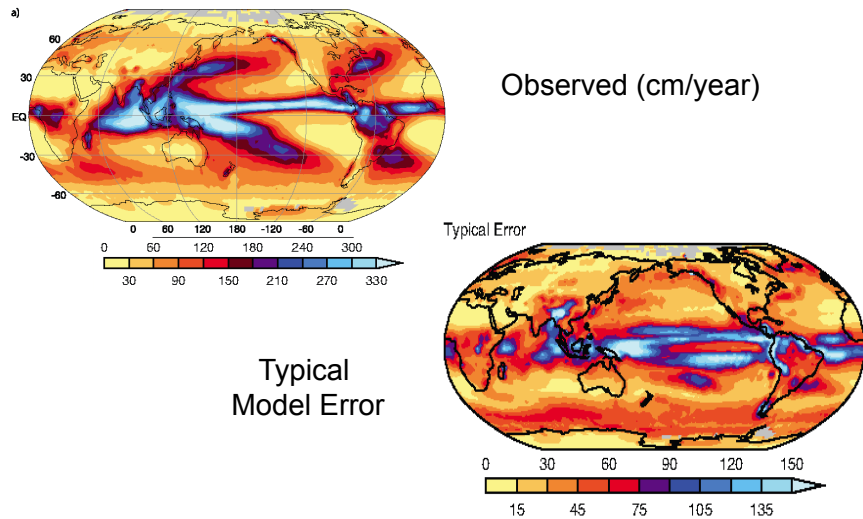

## Surface Wind Stress and Ocean Heat Transport

### Zonal Average Surface Wind Stress

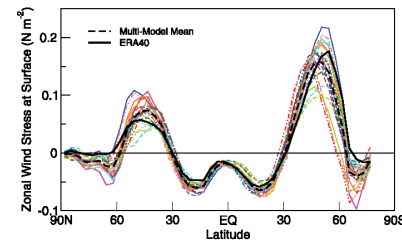

### Northward Ocean Heat Transport

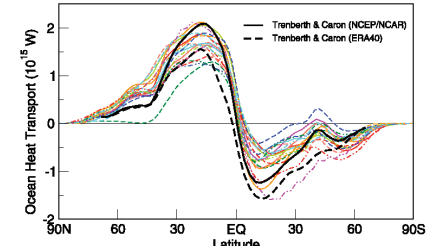

One color line for each model

IPCC 2007

# Annual Average Surface Temperature

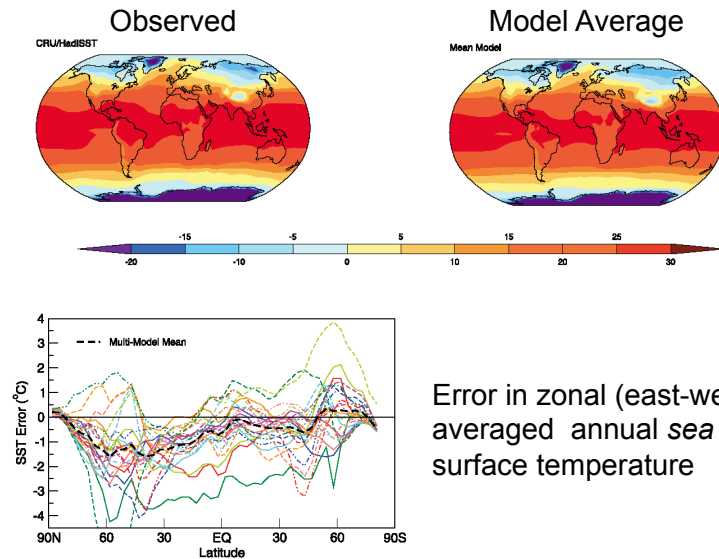

IPCC 2007

# Vertical Distribution of Ocean Temperature

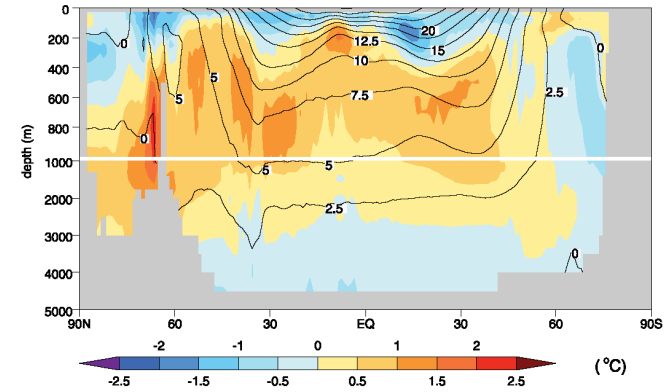

Contours = observed temperature  
Color = error in the 'average of the models'

IPCC 2007

# Sea Ice Extent

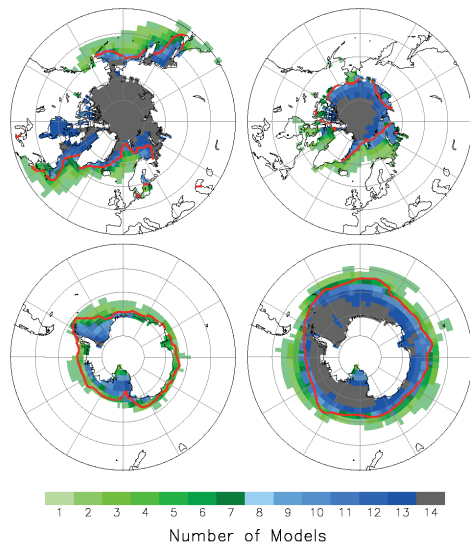

- Red line demarks the position of the 15% sea ice coverage at the end of winter from observations
- Color is the number of models that have at least 15% sea ice coverage

Baseline for observations 1980-1999

Grid size for calculating sea ice coverage is 2.5 x 2.5 latitude-longitude

IPCC 2007

# Natural Variability

- The models simulate accurately the weather on 200km scales
- The models simulate accurately the natural patterns of variability in the atmosphere on 200-1000km scales
  - North Atlantic Oscillation, the eastern Atlantic pattern, the Pacific North American pattern, the Western Pacific pattern, etc
- The models do very poorly the El Nino/Southern Oscillation (ENSO) phenomenon
- The models do poorly in places where topography changes markedly on scales that are smaller than the atmospheric grid (e.g., Puget Sound)
  - In these cases, useful information can be obtained by 'downscaling' (mainly for temperature; precipitation in only some cases)

## More test of the Models

- They have been used to simulate climates of the past and evaluated against the paleo (proxy) data
  - The Early Holocene: 6000 and 8500 years before present (yr BP), when the Sahara was green
  - The Last Glacial Maximum: 23,000 yr BP, the maximum extent of the most recent glacial period
    - Used to evaluate the relative contributions of changes in insolation, land ice (albedo) and carbon dioxide (180ppm vs 280ppm pre-industrial) to the climate changes.
  - The Eocene: 65 million yr BP, when the earth was ice free and much warmer than today (by ~10-15°C) and CO<sub>2</sub> levels were 2-4 times more than today.
    - Note the AR4 models used to do this systematically underestimate the warming of the Eocene
- They have been used to simulate the climate of the 20<sup>th</sup> Century

## Simulating the Global Average Temperature over the 20<sup>th</sup> Century

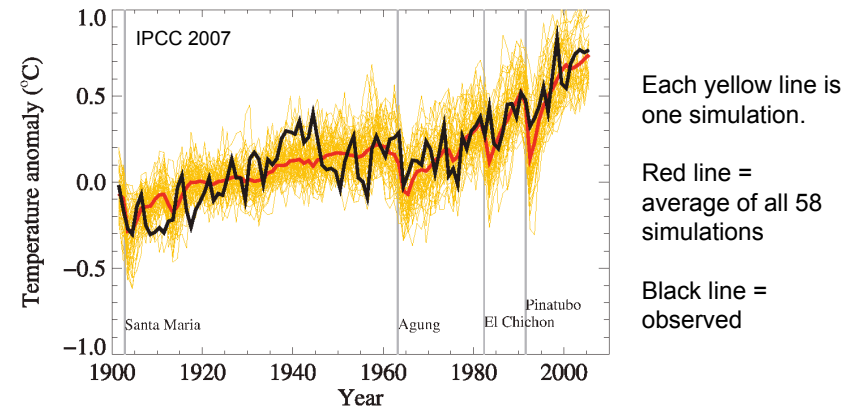

Simulations include natural (solar and volcanic) and human (carbon dioxide, etc) forcing  
14 models were used in this figure with a total of 58 simulations

## Climate Models: Summary

- Based on the laws of physics and chemistry
- They do some things very well
  - Temperature (in general, they do better on larger space & time scales
    - Diurnal: good
    - Weekly and longer time scale (100km to continental scales): very good
    - Global scale: excellent
  - Storm tracks in the midlatitudes
- Some things ok
  - Natural variability in the midlatitudes (especially winter)
  - Snow
- And some things not so well
  - Precipitation
    - Midlatitudes: good
    - Tropics: poor to fair

## 1. Definitions:

### • **The Climate system**

- What is included: the coupled atmosphere, ocean, land surface, and sea ice system
- What usually isn't included:
  - things that don't have much effect on the "climate system"
  - things that change on very long (geologic) time scales are usually considered external to the climate system
    - Examples: changes in location of continents and oceans, changes in land topography)

### • **Natural Variability**

- Variations in climate that are due to *internal* interactions between the atmosphere, ocean, land surface and sea ice.
  - Examples: year-to-year differences in storminess in the Pacific Northwest, drought, the El Niño/Southern Oscillation (ENSO) phenomenon, the North Atlantic Oscillation, etc.

## “Radiative Forcing”

- **Radiative Forcing** (RF) is a measure of the change in the energy balance of the Earth-atmosphere system when factor(s) that affect climate are altered. (IPCC '07)
  - The RF is calculated instantaneously to the alteration (ie, before the atmosphere adjusts to the change)
  - Called 'radiative' because the process that communicates the net change in energy is electromagnetic radiation
- A positive Radiative Forcing results in a net increase in downward energy and thus will lead to a warming of the surface. Examples of RF:
  - increase in the solar luminosity
  - increase in greenhouse gas concentration
- RF allows one to assess and compare the relative importance of different natural and human-induced forcings on climate

## Agents of Climate Change: Forcing

Climate can change due to *external forcing*

### • **Natural Forcing**

- Examples:
  - Volcanoes (scattering particles, albedo  $\alpha$ )
  - changes in the Earth's orbit
  - changes in the solar luminosity ( $S_0$ )

### • **Human Forcing**

- Examples:
  - emissions of greenhouse gases (emissivity  $\epsilon$ )
  - aerosols (tiny particles,  $\alpha$ )
  - land use changed ( $\alpha$ , etc)

## Climate Variability and Climate Change

### 1. Definitions

- The Climate System; Natural and Forced Variability

### 2. Natural Variability

- North Atlantic Oscillation, El Niño/Southern Oscillation

### 3. Forced Change (natural)

- Volcanic Eruptions (scattering particles)
- Changes in the Solar Luminosity

### 4. Forced Change (human)

- Burning of fossil fuels (increasing GH gases)
- Burning of biomass (scattering particles)

## 2. Examples of Natural Variability

- The North Atlantic Oscillation (NAO)
  - (year to year variations in the wintertime storminess in the N. Atlantic)

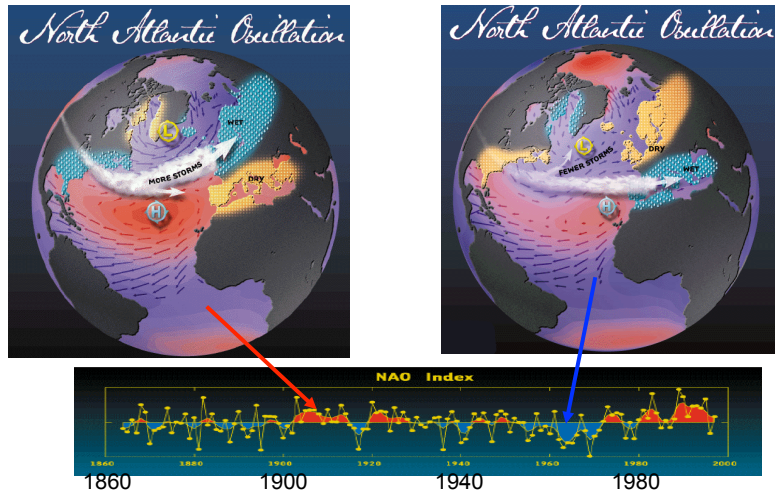

## 2. Examples of Natural Variability

### El Niño/Southern Oscillation (ENSO)

- El Niño/Southern Oscillation (ENSO) is the dominant pattern of climate variability on year-to-year time scales

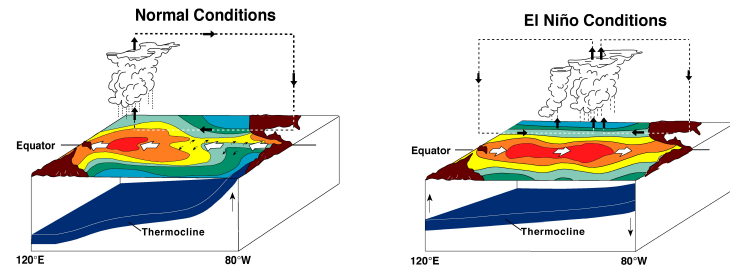

- The physics responsible for ENSO are localized in the tropical Pacific, but ENSO causes global climate anomalies

### ENSO

Changes in the distribution of sea surface temperature are coordinated with changes in atmospheric circulation and rainfall patterns

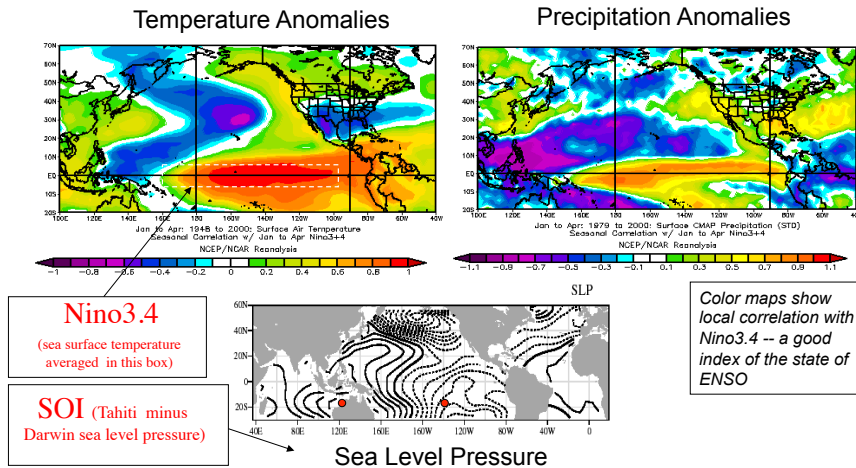

### ENSO

There is a tight coupling between the atmosphere & ocean

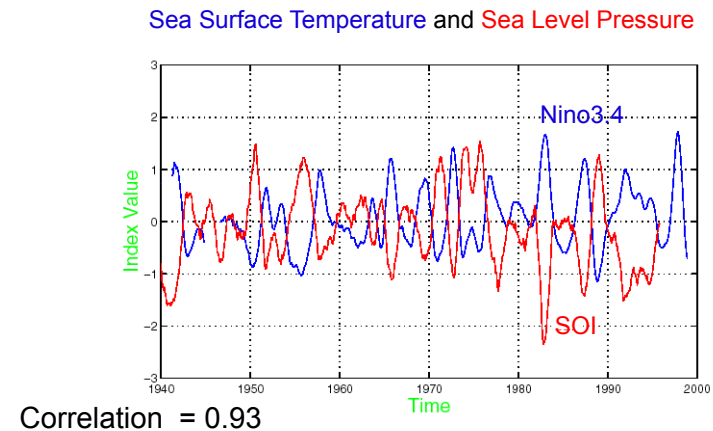

## ENSO

- El Nino is the warm phase of ENSO
  - The tropical Pacific ocean is warmer than usual; rainfall moves from the western Pacific to the central Pacific
- La Nina is the cold phase of ENSO
- El Ninos
  - occur every 3-7 years or so and last about one year
  - El Nino is usually followed by one year of La Nina conditions
- The state of the tropical Pacific (ENSO) is predictable up to one year in advance
  - For example, the average skill for a six month forecast is about 0.85 (perfect forecast =1, no skill =0)
- ENSO causes the global average temperature to change by +/- 0.15°C

ENSO affects the global climate through atmosphere and ocean teleconnections

Anomalies during El Nino: the “warm phase” of ENSO

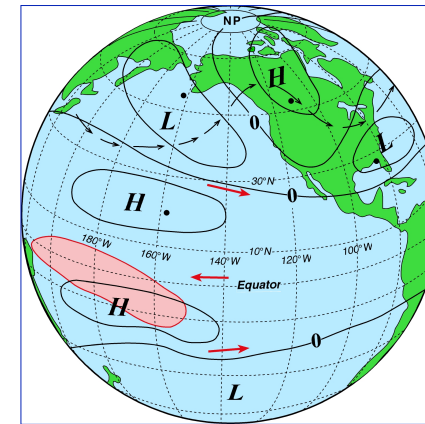

Upper level circulation changes

## The impacts of ENSO

### WARM EPISODE RELATIONSHIPS DECEMBER - FEBRUARY

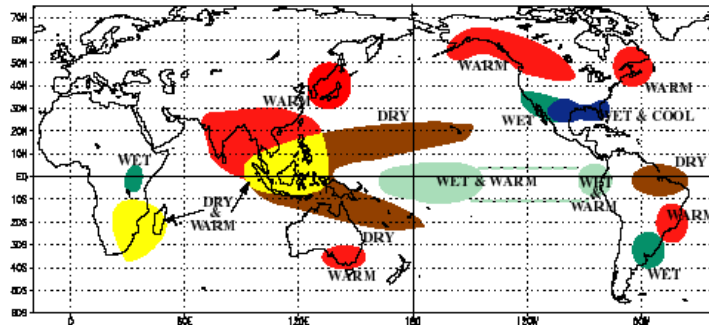

- ENSO alters the climate on a global scale. For example, ENSO impacts
  - Rainfall in Indonesia (correlation 0.7)
  - about 1/4 of the variability in wintertime temperature and storminess in the western US
  - the probabilities of extreme weather events on a global scale

## Current Tropical Pacific Ocean Temperature Anomalies

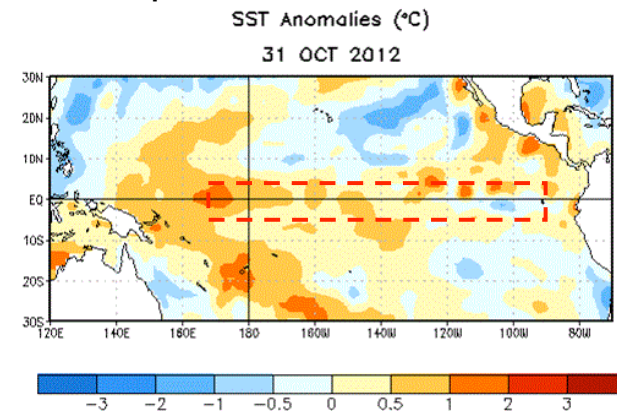

Figure 1. Average sea surface temperature (SST) anomalies (°C) for the week centered on 31 October 2012. Anomalies are computed with respect to the 1981-2010 base period weekly means.

# Most recent El Nino Forecasts

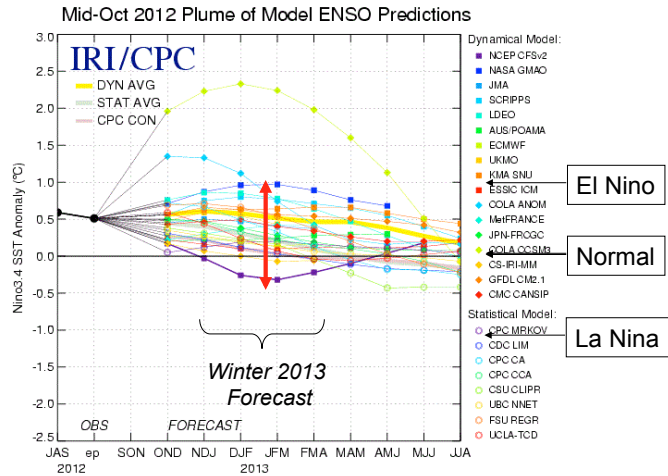

Figure 6. Forecasts of sea surface temperature (SST) anomalies for the Niño 3.4 region (5°N-5°S, 120°W-170°W). Figure courtesy of the International Research Institute (IRI) for Climate and Society. Figure updated 15 October 2012.

[http://iri.columbia.edu/climate/ENSO/currentinfo/SST\\_table.html#figure](http://iri.columbia.edu/climate/ENSO/currentinfo/SST_table.html#figure)

# Historical Impact of ENSO on the US

<http://www.cpc.ncep.noaa.gov/products/precip/CWlink/MJO/enso.shtml>

## Temperature in January - March (in C)

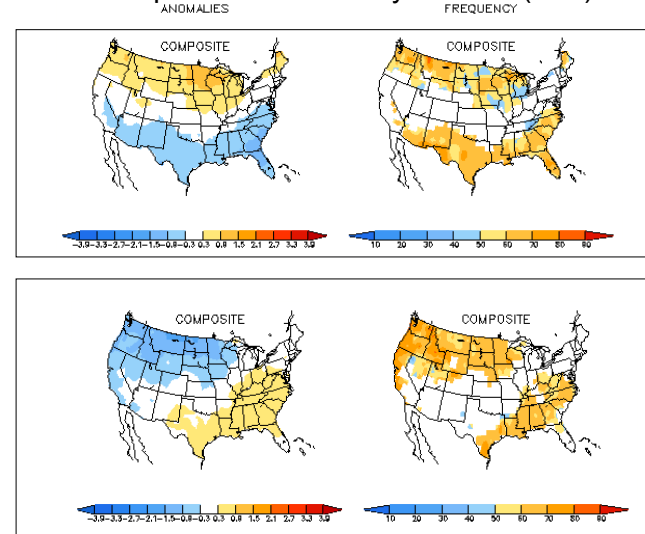

# Historical Impact of ENSO on the US

## Precipitation in January - March (in mm)

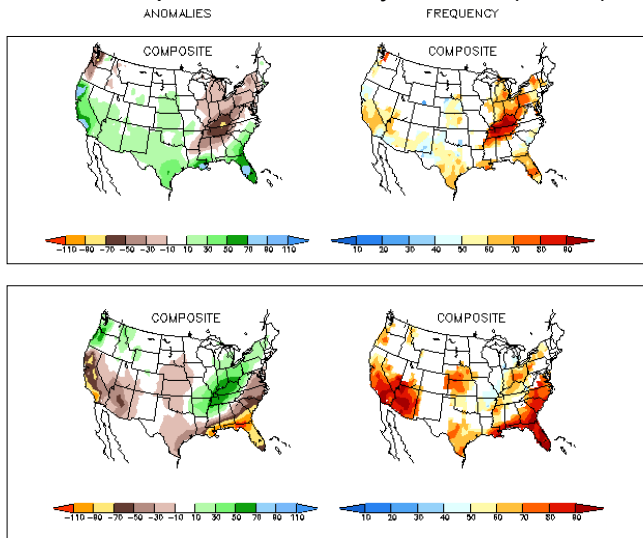

# Historical Impact of ENSO on the US

## Snowfall in January - March (in inches)

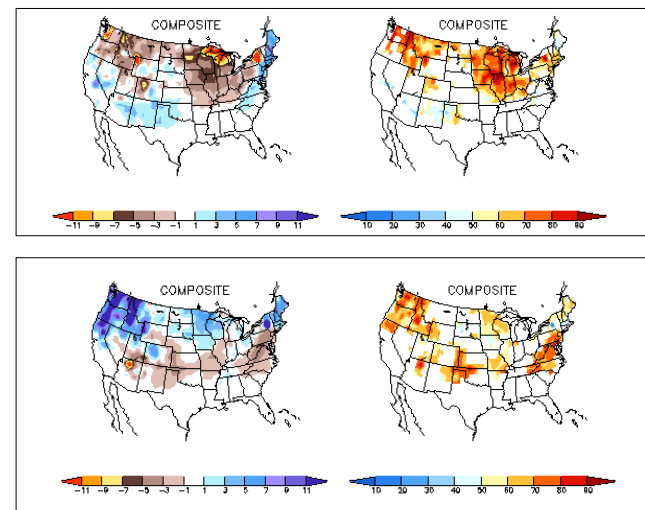

## Historical Impact of ENSO

### Temperature in December – February

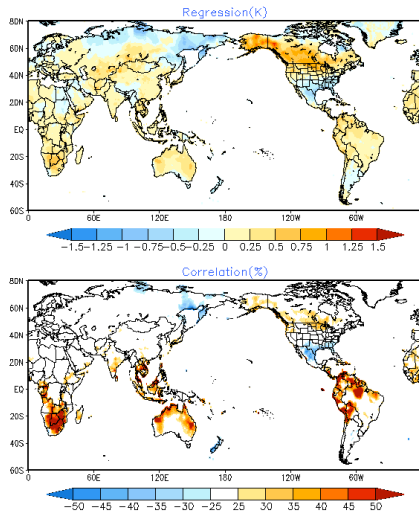

Regression  
(how much change  
in a modest El Nino)

Correlation

## Historical Impact of ENSO

### Precipitation in December – February

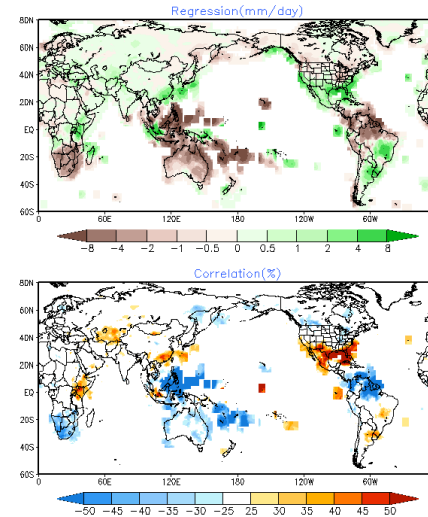

Regression  
(how much change  
in a modest El Nino)

Correlation

## Climate Variability and Climate Change

### 1. Definitions

- The Climate System; Natural and Forced Variability

### 2. Natural Variability

- North Atlantic Oscillation, El Nino/Southern Oscillation

### 3. Forced Change (natural)

- Volcanic Eruptions (scattering particles)
- Changes in the Solar Luminosity

### 4. Forced Change (human)

- Burning of fossil fuels (increasing GH gases)
- Burning of biomass (scattering particles)

## 3. Forced Change: Natural

### Volcanoes

- Emit sulfur dioxide into atmosphere
- The most explosive eruptions can loft sulfur dioxide 20-30km -- into the stratosphere, where it turns into sulphate particles (aerosols)
- Once in the stratosphere, the winds distribute the sulphate aerosols globally
- The smallest particles fall-out in one or two years
- Climate Impact:
  - Small sulphate particles reflect radiation in the visible band; hence they reduce the insolation arriving at the surface
  - This causes a cooling of the planet -- as much as 0.5°C -- that can last for up to two years

## Mount Pinatubo, Philippines (June 1991)



.... resulted in a reduction insolation (sunlight) reaching the surface of 2-3 W/m<sup>2</sup> for about a year

## The impact of Mount Pinatubo eruption: Model vs Observations

Departure of Global Average Temperature from April-June 1991 average

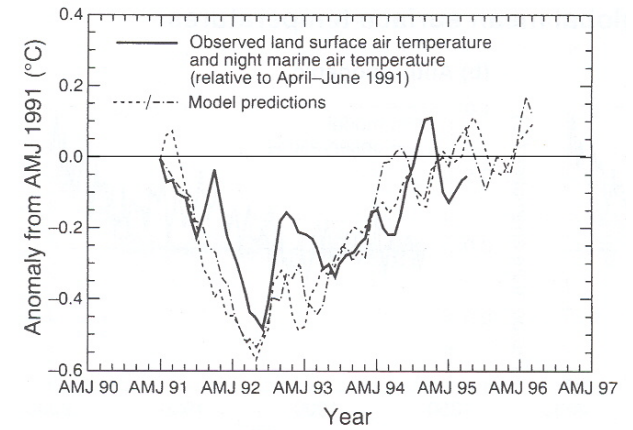

Pinatubo caused the planet to be about 0.35°C cooler for about 18 months

Houghton Fig. 5.21

## The impact of Mount Pinatubo eruption: Precipitation

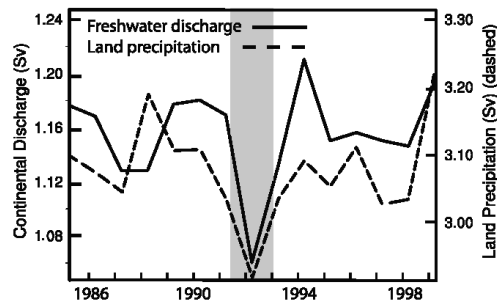

Mount Pinatubo also caused about 5% less global averaged precipitation

Trenberth and Dai 2007

## Mechanism of Volcanic Perturbation

- Sulphate particles in the stratosphere reflect sunlight, hence increase the planetary albedo
- Process is well understood but ...
  - Amount of sunlight scattered depends greatly on size and amount of aerosol particles
  - The global monitoring of aerosols began in ~1980
- Hence, the history of the amplitude of the ‘forcing’ before 1980 is poorly known

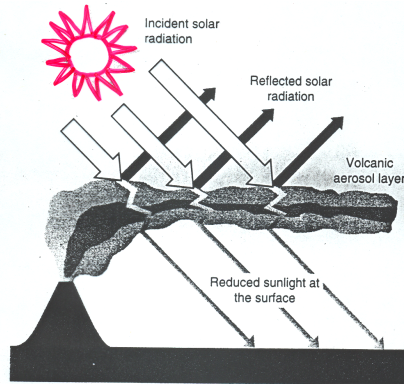

## Major Volcanic Eruptions in the past

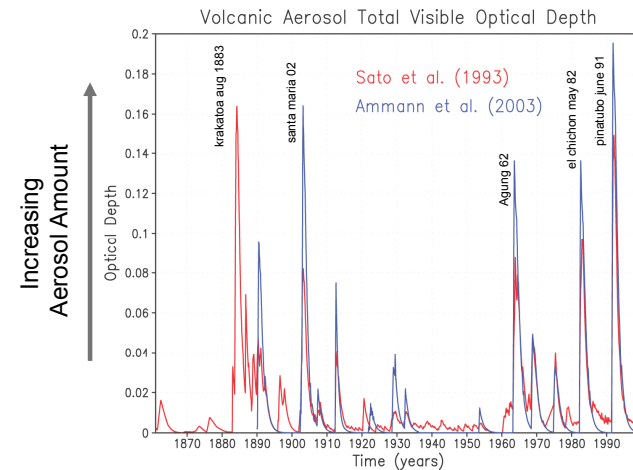

Estimates from two different groups

IPCC 2007 Fig 2.18

## Volcanic Eruptions and Global Temperature

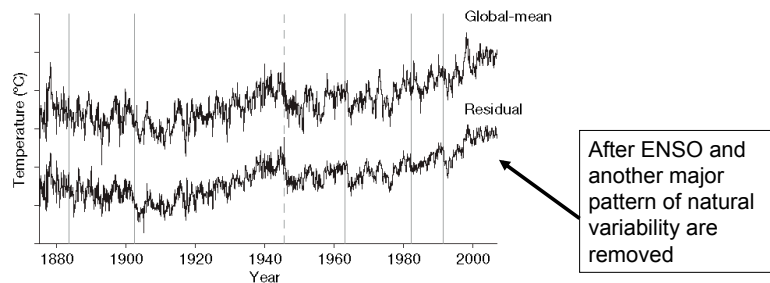
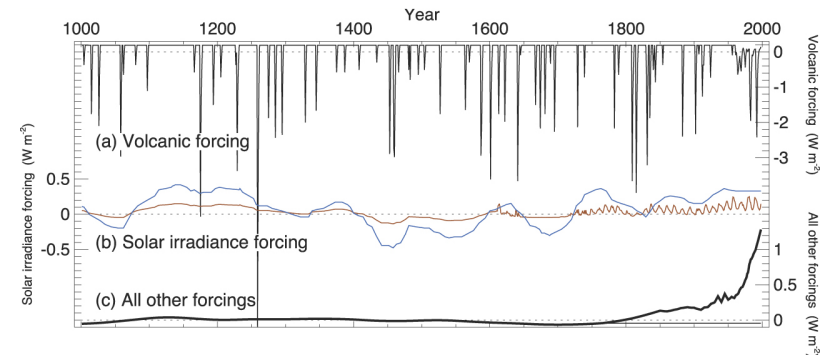

**Figure 2 |** The original (that is, unfiltered) and residual global-mean temperature time series duplicated from Fig. 1. The solid vertical lines denote volcano eruption dates: from left to right, Mts Krakatoa, Santa Maria, Agung, El Chichón and Pinatubo. The dashed vertical line denotes the month of August 1945. Vertical axis shows temperature anomalies; tickmarks indicate steps of 0.5°C.

- Suggestion that the typical large volcano can cool the planet by ~0.3°C for about a year or so

Thompson et al 2008

## Major Volcanic Eruptions in the past



Estimates of forcing amplitude are highly uncertain because amount and size of aerosol lofted is only crudely estimated



Mt. Rinjani, Indonesia 1258

IPCC 2007 Fig 6.14

## Climate Variability and Climate Change

### 1. Definitions

- The Climate System; Natural and Forced Variability

### 2. Natural Variability

- North Atlantic Oscillation, El Nino/Southern Oscillation

### 3. Forced Change (natural)

- Volcanic Eruptions (scattering particles)
- Changes in the Solar Luminosity

### 4. Forced Change (human)

- Burning of fossil fuels (increasing GH gases)
- Burning of biomass (scattering particles)

## Forced Change: Changes in the Sun's output

- Sunspots are associated with a small *increase* in energy coming from the Sun
  - Sunspot numbers vary (11 year cycle, and other poorly understood time scales)
- We have direct estimates of the change in insolation since 1978
  - The solar constant varies by +/- 0.05% over the sunspot cycle, or about +/- 0.5W/m<sup>2</sup>, or about +/-0.125 W/m<sup>2</sup> averaged over the whole Earth
- Changes are too small to explain correlated variability in global temperature (so proponents of solar forcing offer exotic ideas -- often involving cosmic rays and clouds -- to amplify the impact):
  - Expect ~0.05°C changes in global temperature

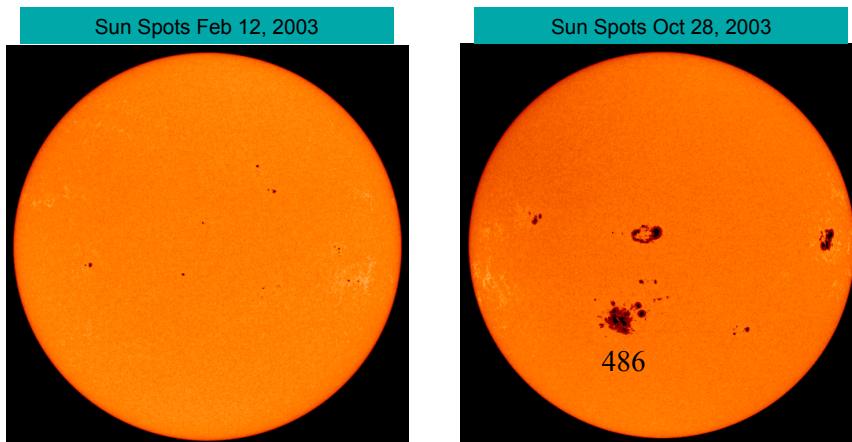

"one of the most powerful solar flares in years... erupted from sunspot 486."

[www.spaceweather.com](http://www.spaceweather.com)

## The Solar Constant

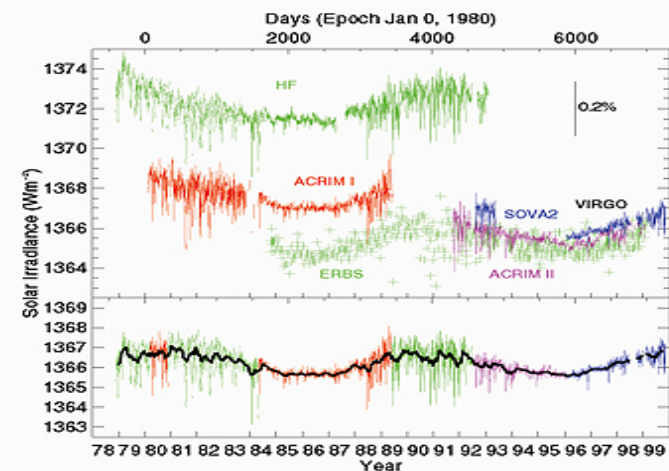

Direct measurements of Solar luminosity since 1978

# The Solar Constant

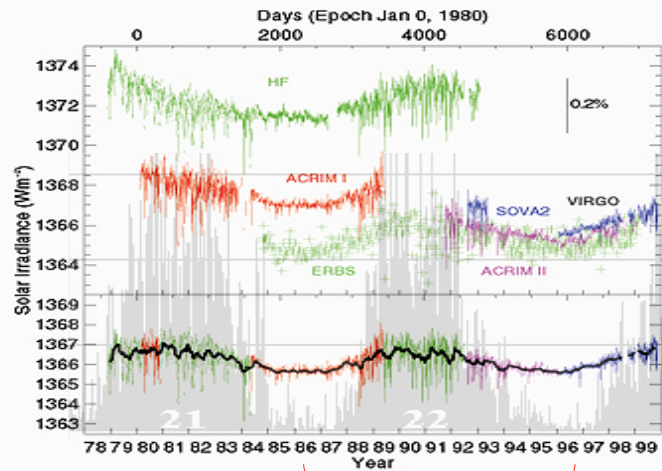

Sunspot cycle #22

# Sunspot observations

25 BC: First sunspot records in China  
 1611: Sunspots discovered by Europeans (with telescopes)

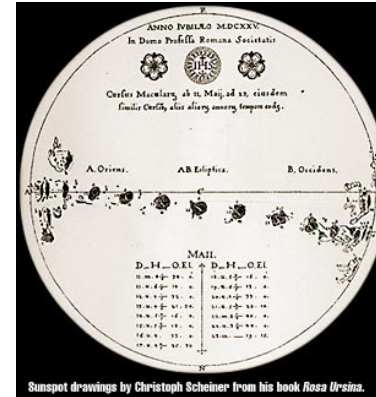

An image of the region around a sunspot. The mottled appearance is due to turbulent eruptions at the surface of the sun.

# How to view sunspots

**NO !!!**

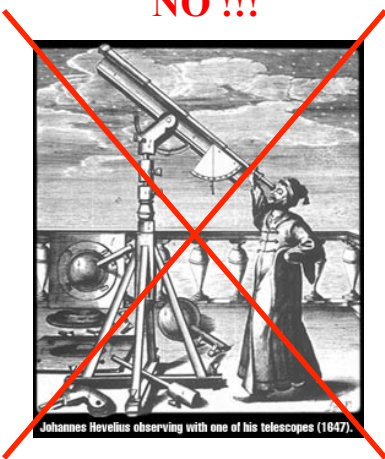

**Yes**

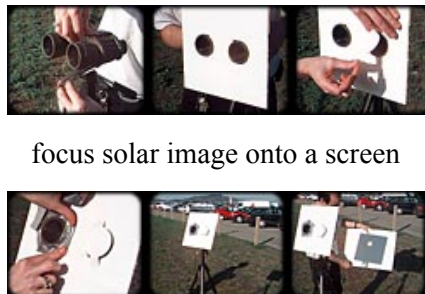

focus solar image onto a screen

# Sunspot Evolution

DAILY SUNSPOT AREA AVERAGED OVER INDIVIDUAL SOLAR ROTATIONS

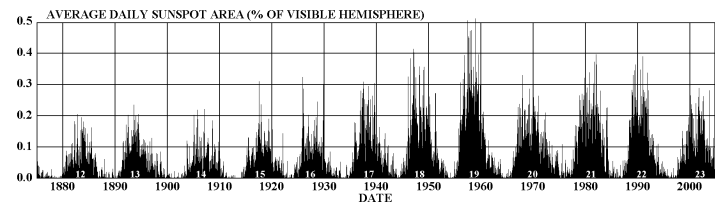
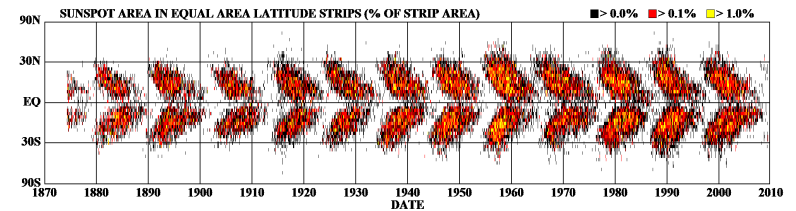

<http://science.msc.nasa.gov/solpod/solar/images/bbf.gif>

NASA/SSSTC/HATHAWAY 2004/11

Cycle is on average 10.55 yrs (range is 9 to 14 yr)

## Sunspot Numbers

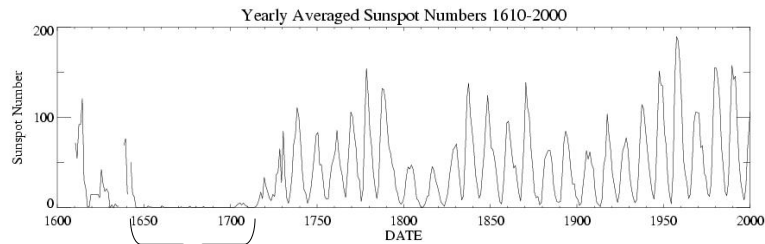

Maunder Minimum in Sunspots  
(Also the time of the "Little Ice Age" in Europe)  
Coincidence?

## The Solar Constant in the past

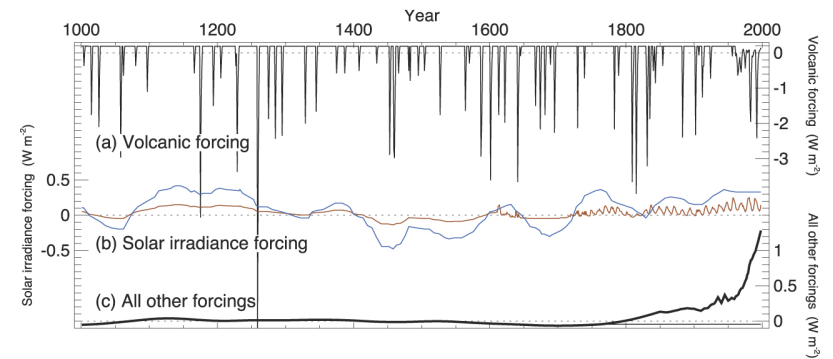

*History of Sun's luminosity is revised downward (to brown curve)*

Estimate comes from: (i) extrapolating direct insolation-sunspot number relationship; (ii) modeling of the solar magnetic flux;  $^{14}\text{C}$  and  $^{10}\text{Be}$  measurements in trees (cosmogenic flux); (iii) observing range of luminosity in other Sun-like stars.

IPCC 2007 Fig 6.14

## Climate Variability and Climate Change

### 1. Definitions

- The Climate System; Natural and Forced Variability

### 2. Natural Variability

- North Atlantic Oscillation, El Niño/Southern Oscillation

### 3. Forced Change (natural)

- Volcanic Eruptions (scattering particles)
- Changes in the Solar Luminosity

### 4. Forced Change (human)

- Burning of fossil fuels (increasing GH gases)
- Burning of biomass (scattering particles)

## Forced Change: Three Important GH gases influenced by human activity

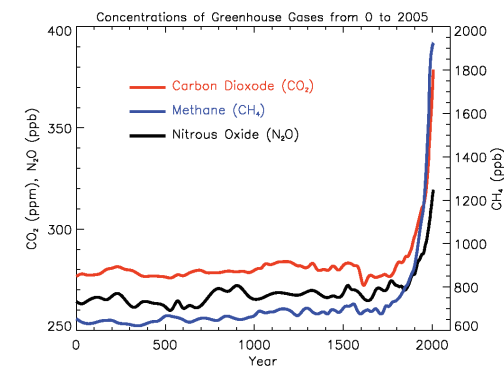

**FAQ 2.1, Figure 1.** Atmospheric concentrations of important long-lived greenhouse gases over the last 2,000 years. Increases since about 1750 are attributed to human activities in the industrial era. Concentration units are parts per million (ppm) or parts per billion (ppb), indicating the number of molecules of the greenhouse gas per million or billion air molecules, respectively, in an atmospheric sample. (Data combined and simplified from Chapters 6 and 2 of this report.)

IPCC 2007

# Forced Change: Three Important GH gases influenced by human activity

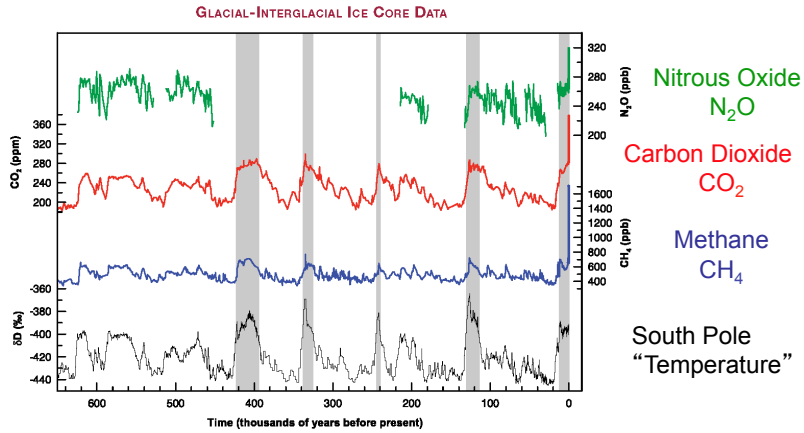
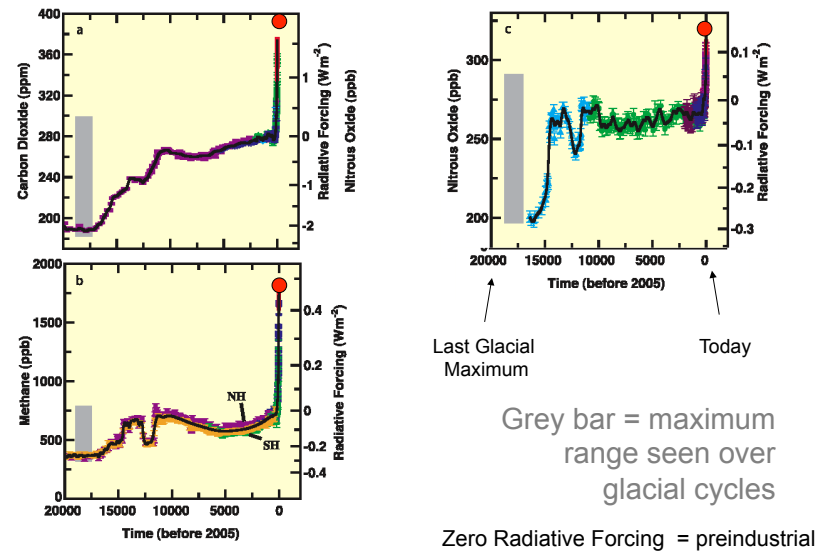
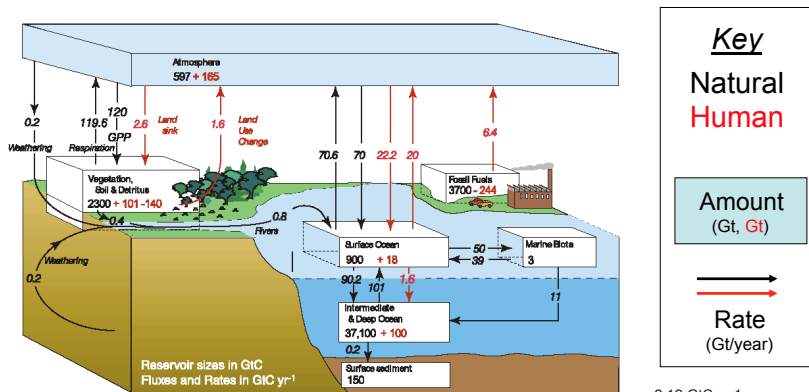

Figure TS.1. Variations of deuterium ( $\delta D$ ) in antarctic ice, which is a proxy for local temperature, and the atmospheric concentrations of the greenhouse gases carbon dioxide ( $CO_2$ ), methane ( $CH_4$ ), and nitrous oxide ( $N_2O$ ) in air trapped within the ice cores and from recent atmospheric measurements. Data cover 650,000 years and the shaded bands indicate current and previous interglacial warm periods. (Adapted from Figure 6.3)

# Human Forcing: Changes in GH gases



## The Carbon Cycle is complex



2.12 GtC = 1 ppm  
1 Gt = billion tonnes

Where is the carbon *circa 1990AD*?

Ocean (non-biota) 38,150 + 118 Gt  
 Land Biosphere 2300 - 39  
 Fossil Fuels 3700 - 244  
 Ocean Biota 3  
 Atmosphere 600 + 165  
 Rocks gobs

## The Carbon Cycle is complex

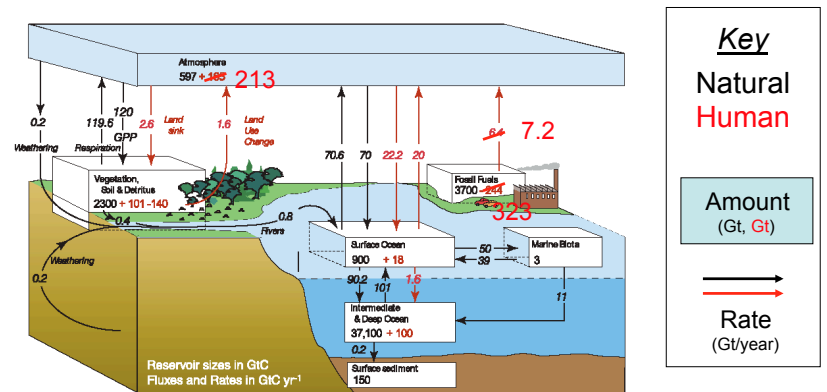

Where is the carbon *circa 1990AD 2005AD*?

Ocean (non-biota) 38,150 + ~~118~~ + 145  
 Land Biosphere 2300 - ~~39~~ - 28  
 Fossil Fuels 3700 - ~~244~~ - 323  
 Ocean Biota 3  
 Atmosphere 600 + ~~165~~  
 Rocks gobs

# Atmospheric Carbon Dioxide

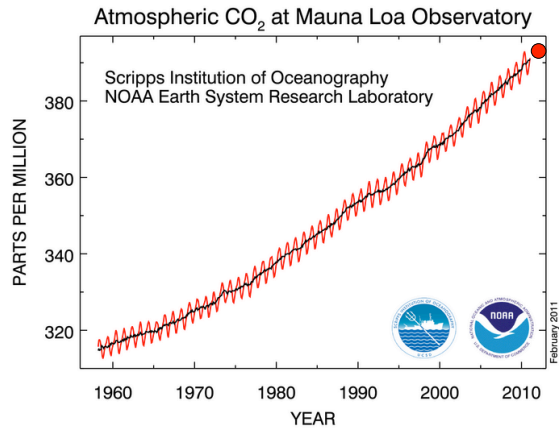

- Carbon Dioxide is increasing because of burning fossil fuels (85%) and deforestation (15%)
  - 25% increase in the past 50 years; 10% increase since 1991.

# Fun Facts about CO<sub>2</sub>

- Since Industrial revolution
  - 75% of carbon emission is due to fossil fuel burning and cement production; 25% due to land use.
- Today's emissions (2012): total 9.5 Gt/yr
  - 85% (8Gt/yr) due to fossil fuel and cement
  - 15% (1.5 Gt/yr) due to land use
- CO<sub>2</sub> in the atmosphere has increased:
  - About 10% since 1991;
  - 25% over the past 50 yrs;
  - 40% increase since the beginning of the industrial revolution
- Today: About 1/2 of what is emitted by humans stays in the atmosphere
  - the other half goes into ocean (2.7 Gt/yr) and land (2.2 Gt/yr)

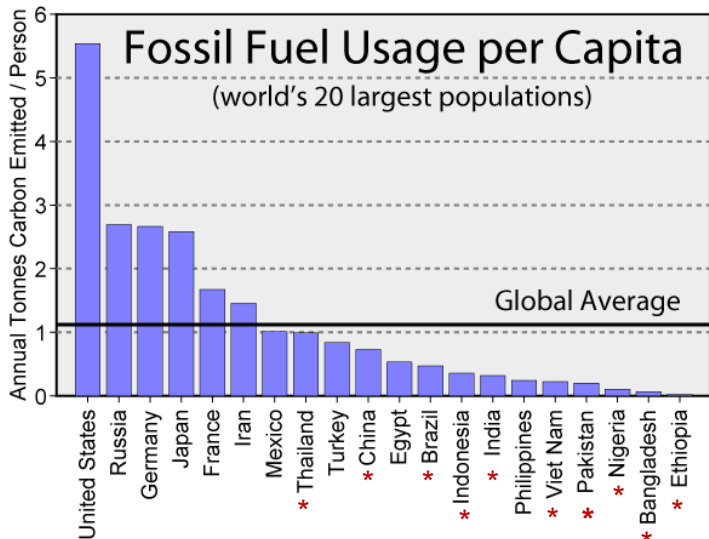

\* = Countries most affected by Global Warming

## How do we know the increase in CO<sub>2</sub> is due to human activity?

- Inventory industry and government: how much coal and oil is sold each year?
- Look at isotopes of carbon in the atmosphere carbon dioxide
  - Cosmic rays create a little bit of C<sup>14</sup> in the atmosphere, and plants take this in along with lots of normal carbon (C<sup>12</sup>)
  - Fossil fuels have no C<sup>14</sup> because it is old (all C<sup>14</sup> has decayed to N<sup>14</sup>; half life 5370yrs)
  - So adding CO<sub>2</sub> to the atmosphere from burning fossil fuels will cause the atmospheric C<sup>14</sup>/C<sup>12</sup> ratio to decrease over time.
- Look at how oxygen in atmosphere has change
- Inventory industry: how much cement is produced each year?

# Human Forcing: Carbon Dioxide

## Sources and Sinks of Carbon to the Atmosphere

	1980s	1990s	2000-2005	2010
Atmospheric increase	3.3 ± 0.1	3.2 ± 0.1	4.1 ± 0.1	4.6
Fossil carbon dioxide emissions	5.4 ± 0.3	6.4 ± 0.4	7.2 ± 0.3	8.0
Net ocean-to-atmosphere flux	-1.8 ± 0.8	-2.2 ± 0.4	-2.2 ± 0.5	-2.7
Net land-to-atmosphere flux	-0.3 ± 0.9	-1.0 ± 0.6	-0.9 ± 0.6	-2.2
<i>Partitioned as follows</i>				
Land use change flux	1.4 (0.4 to 2.3)	1.6 (0.5 to 2.7)	NA	1.5
Residual land sink	-1.7 (-3.4 to 0.2)	-2.6 (-4.3 to -0.9)	NA	(-3.7)

<sup>3</sup> Fossil CO<sub>2</sub> emissions include those from the production, distribution and consumption of fossil fuels and from cement production. Emission of 1 GtC corresponds to 3.67 GtCO<sub>2</sub>.

<sup>4</sup> As explained in Section 7.3, uncertainty ranges for land use change emissions, and hence for the full carbon cycle budget, can only be given as 65% confidence intervals.

Units are Giga tonnes of Carbon per year

(1 Gt = 10<sup>9</sup> tonnes; 1 tonne = 2200 lbs)

Human input (burning of fossil fuel) is increasing

# Human Forcing: Carbon Dioxide

## Sources and Sinks of Carbon to the Atmosphere

	Overall Gain (1750-2005)	Overall Rate (1750-2005)	Rate (2000-2005)
Emission (Fossil Fuel & Cement) + Land Use	323 +160 Gt	1.3+0.7 Gt/year	7.2 FF +1.6 (land use) Gt/year
In Atmosphere	213 Gt	0.8	4.1
In Ocean	145 Gt	0.5	2.2
In Land	125 Gt	0.4	2.5

Amount presently in atmosphere: ~ 835 Gt

# Forced Change: Three Important GH gases influenced by human activity

Gas	Human Source	Pre-Indust. Value	2005	RF in 2000 (W/m <sup>2</sup> )
Carbon Dioxide CO <sub>2</sub>	Burning Fossil Fuel & Cement Production	280 ppm	379 ppm	+1.66
Methane CH <sub>4</sub>	Rice agriculture, livestock, landfills	700 ppb	1774 ppb	+0.48
Nitrous Oxide N <sub>2</sub> O	Agriculture (fertilizer)	270 ppb	319 ppb	+0.16

Compare to solar (+/- 0.12 W/m<sup>2</sup>) or volcanic (~ -2 W/m<sup>2</sup>)

# For some GH gases, some human sources are comparable to Nature's sources

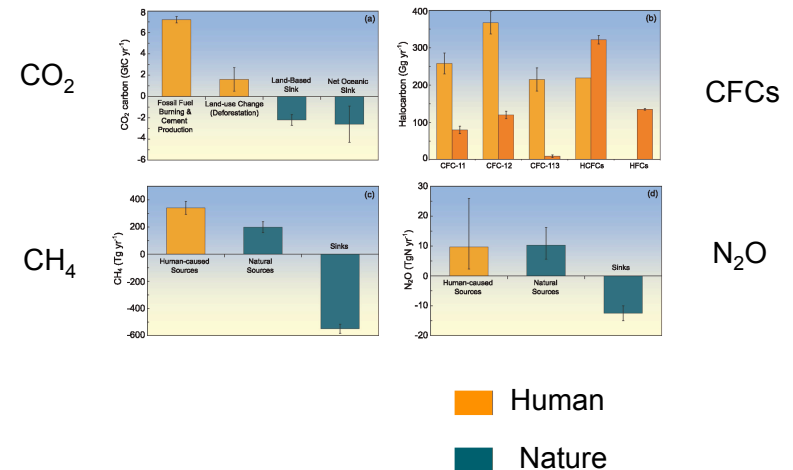

Circa 2005

## Human Forcing: Other GH gas changes

- Tropospheric Ozone (pollution and volatile organic carbon emission from planted forests): RF ~ +0.35 W/m<sup>2</sup>
- CFCs and HCFC (industrial) RF ~ + 0.35 W/m<sup>2</sup>

## Tool: Residence time

- The residence time scale is the typical time it takes something to move through a reservoir when the system is in equilibrium (standard definition)
- It can also be thought of as the time it takes to see significant changes in a reservoir, if the inputs or outputs change (non-standard definition)

## Tool: Residence time

- For example, you have 10,000\$ in your bank account. You add 2000\$ per month to balance your monthly expenses of 2000\$.
- What is the residence time of a typical dollar in your bank account?

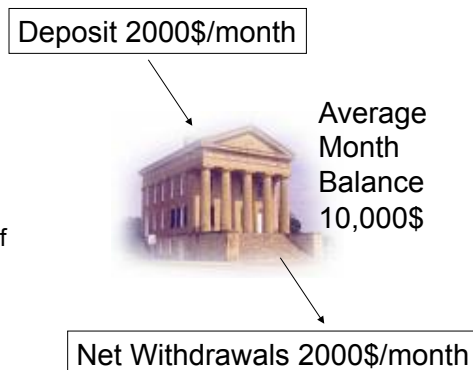

$$\text{Residence time} = 10,000\$ / (2000\$/\text{mo}) = 5 \text{ months}$$

## Tool: Residence time

Residence time is a characteristic time for seeing large changes in some quantity. Another example: What is the residence time fossil fuel reservoir?

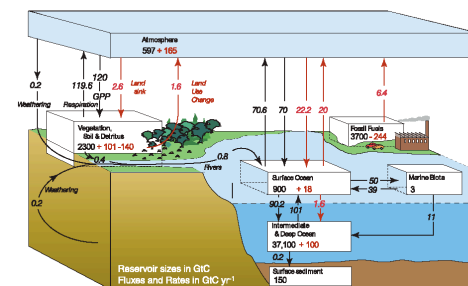

### Key

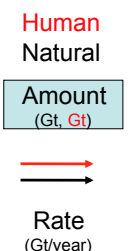

$$\begin{aligned} \text{Residence time} &= \text{amount} / \text{rate of input} \\ &= 3700 \text{ Gt} / 6.4 \text{ Gt per year} = 580 \text{ yrs} \end{aligned}$$

## Human Forcing: Aerosols

*Human activity puts small particles in the troposphere that greatly affect the Earth's radiation balance*

- Sulfates from the burning of coal
  - Direct effect: reflects visible light
  - Indirect effect: increases albedo of clouds
- Soot (organic and black carbon) from the burning of biomass
  - Absorbs visible light (warms atmosphere and cools surface)
- Industrial dust

## Human Forcing: Aerosols

- Aerosols injected into the *troposphere* settle out quickly (about 2-5 days)
  - Mixing of air that brings it in contact with the ground
  - Scavenged by raindrops
- Hence, aerosols injected into the troposphere don't get far from the source

$$\begin{aligned} \text{Distance} &= \text{wind speed} \times \text{residence time} \\ &= 15 \text{ m/s} \times (3 \times 24 \times 60 \times 60 \text{ s}) \\ &= 4 \times 10^6 \text{ m} = 4000 \text{ km} \end{aligned}$$

## Aerosols in the atmosphere (human and natural)

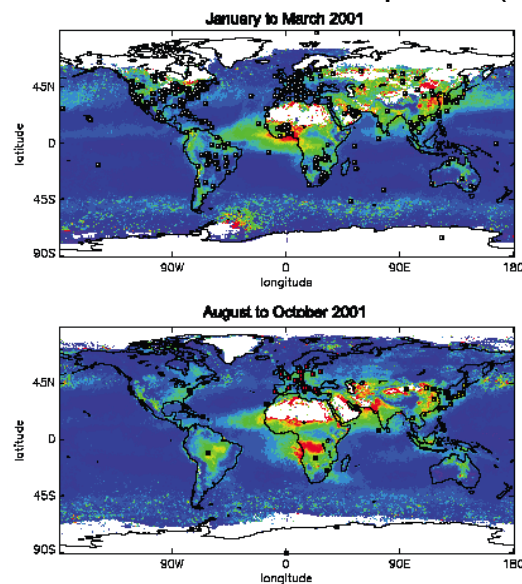

Fraction of solar energy in mid-visible band reaching the surface (when no clouds are present)

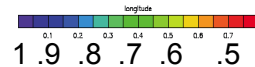

## Impact of Aerosols: Radiative Forcing

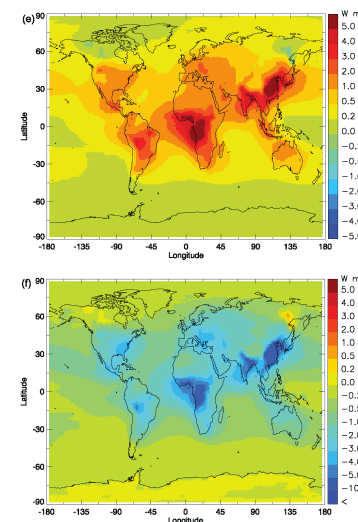

Shortwave absorbed in atmosphere by human sources of aerosols (SO<sub>4</sub>, black carbon)

Shortwave lost to the surface due to human sources of aerosols (SO<sub>4</sub>, black carbon)

Fig 2.12 of IPCC 2007 WG1

# Climate Variability and Climate Change

## Modeled and Observed Temperature Change 1850-2000

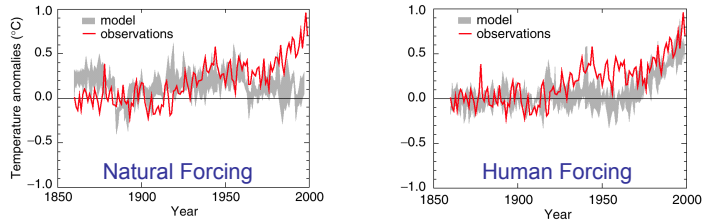

Natural Forcing  
Sun, Volcanic

Human Forcing  
Fossil Fuel and  
Biomass Burning

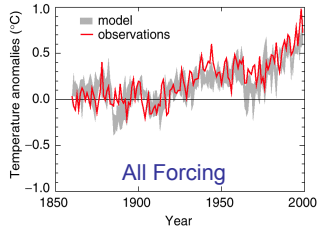

Next: How we determine which changes are due to *natural variability* and which changes are due to *forcing (natural and human induced)*?

# Global Warming: Science, Projections and Uncertainties

An overview of the basic science

1. A Brief History of "Global Warming"
2. Climate Change: 1850-2007
3. Projections of Climate Change: 2100 and beyond
4. What's new in Climate Science?
5. Conclusions

# Global Warming: Science, Projections and Uncertainties

An overview of the basic science

1. A Brief History of "Global Warming"
2. Climate Change: 1850-2007
3. Projections of Climate Change: 2100 and beyond
4. What's new in Climate Science?
5. Conclusions

## Greenhouse Effect: not a new problem



Joseph Fourier, 1827:

Recognized the earth (not the atmosphere) is mainly heated by the Sun, and gases in the atmosphere slow the heat loss to space and make the surface of the planet warmer than it would otherwise be.



John Tyndall, 1860s:

Recognized water vapor and carbon dioxide are greenhouse gases.

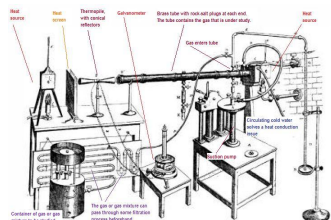

Tyndall's thermopile

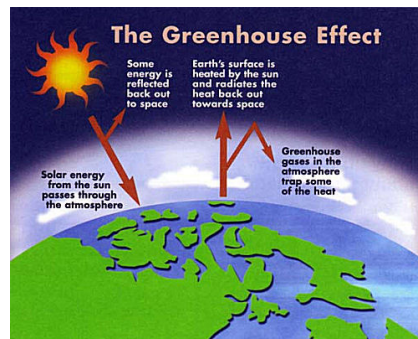

## Global Warming: not a new problem



Svante Arrhenius, 1896

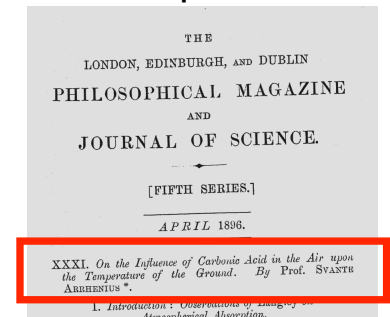

- In 1894, Hoggbon calculated the amount of carbon dioxide added to the atmosphere due to burning coal
- In 1896, Arrhenius:
  - estimated that it would take 3000 years for humans to double atmospheric carbon dioxide ❌
  - calculated that doubling atmospheric carbon dioxide would increase the global temperature by 5-6 degrees C. ✓

## Atmospheric Carbon Dioxide

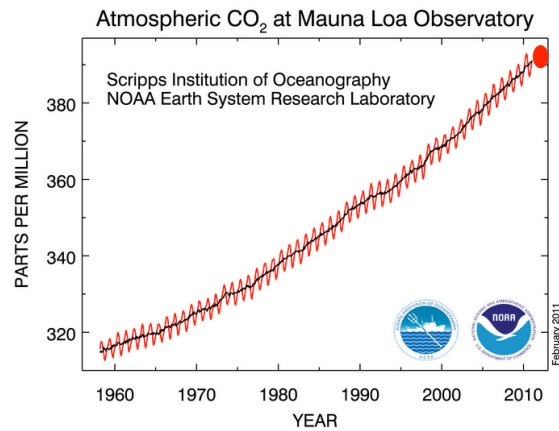

- Carbon Dioxide is increasing today because of the burning fossil fuels (85%) and deforestation (15%)
  - 25% increase in the past 50 years; 10% increase since 1991;

## Atmospheric Carbon Dioxide

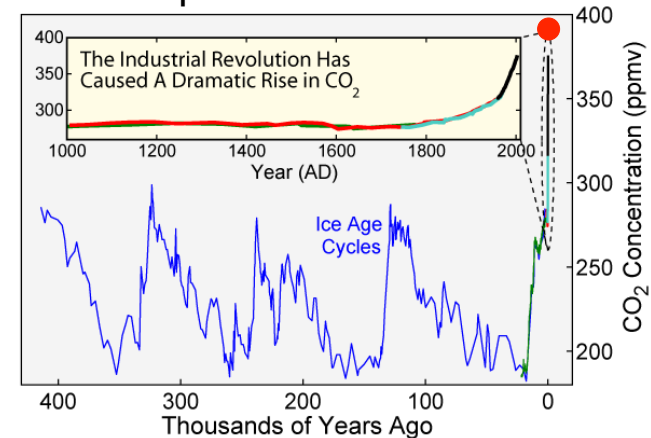

- Carbon dioxide increased by 40% since 1750 because of the burning fossil fuels (75%) and deforestation (25%)
  - Fate: 40% in atmosphere, 35% in land and 25% in ocean
- The *rate of increase* is 100-1000 times faster than Nature can change CO<sub>2</sub>

## Global Warming: Science, Projections and Uncertainties

An overview of the basic science

1. A Brief History of “Global Warming”
2. Climate Change: 1850-2007
3. Projections of Climate Change: 2100 and beyond
4. What’s new in Climate Science?
5. Conclusions

## “Radiative Forcing”

- **Radiative Forcing** (RF) is a measure of the change in the energy balance of the Earth-atmosphere system when factor(s) that affect climate are altered. (IPCC ‘07)
  - The RF is calculated instantaneously to the alteration (ie, before the atmosphere adjusts to the change)
  - Called ‘radiative’ because the process that communicates the net change in energy is electromagnetic radiation
- A positive Radiative Forcing results in a net increase in downward energy and thus will lead to a warming of the surface. Examples of RF:
  - increase in the solar luminosity
  - increase in greenhouse gas concentration
- RF allows one to assess and compare the relative importance of different natural and human-induced forcings on climate

Why has the global average temperature increased? It's more than just CO<sub>2</sub>

Figure SPM.2

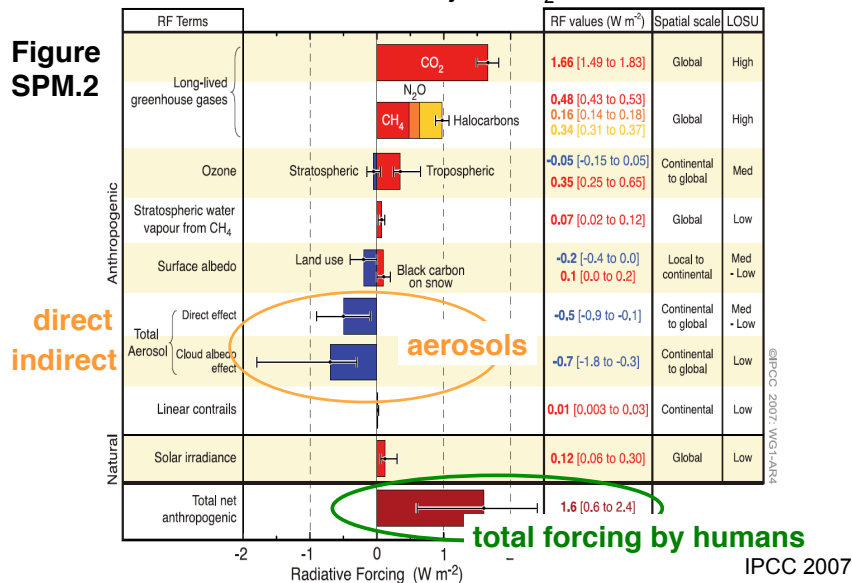

## Human Forcing: summary

- Greenhouse gases:
  - carbon dioxide, methane, nitrous oxide, ozone, CFCs:
    - In the net, they cause a RF of +2.9 W/m<sup>2</sup>
  - Relationship between gas concentration and radiative forcing RF is well known (typical uncertainty is ≤10%)
    - For example, the RF of CO<sub>2</sub> is 1.66 +/- 0.18 W/m<sup>2</sup>
- Aerosols
  - From burning coal and biomass
  - Radiative Forcing is negative and has two contributions:
    - Direct Effect of scattering (reflecting) sunlight: RF = -0.4 +/- 0.4 W/m<sup>2</sup>
    - Indirect Effect of decreasing the size of droplets that make up clouds. The amplitude of the indirect effect is highly uncertain: -0.3 to -1.8 W/m<sup>2</sup>

## Comments on Human and Natural Forcings

- Human input of GH gases (carbon dioxide, methane, nitrous oxide, ozone, CFCs) has warmed the planet:
  - net RF = +2.9 W/m<sup>2</sup>
  - The largest single warming factor is increased CO<sub>2</sub>: RF = 1.66 W/m<sup>2</sup>
- Human input of aerosols cools the Earth
  - Aerosol RF = -1.3 [-0.3 to -2.5 W/m<sup>2</sup>]
  - This cooling is localized to nearby the source region
- The net forcing of the climate system due to human activities is positive (a warming):
  - net RF = +1.6 [+0.6 to +2.4 W/m<sup>2</sup>] = +2.9 - 1.3
- Hence, the 20th Century warming would have been much greater without human caused aerosols
- The time scale to get back to pre-industrial forcing is determined by the time it takes for nature to remove the dominant human forcing agent, CO<sub>2</sub> - about 10,000 years.

## Climate Variability and Climate Change

### Modeled and Observed Temperature Change 1850-2000

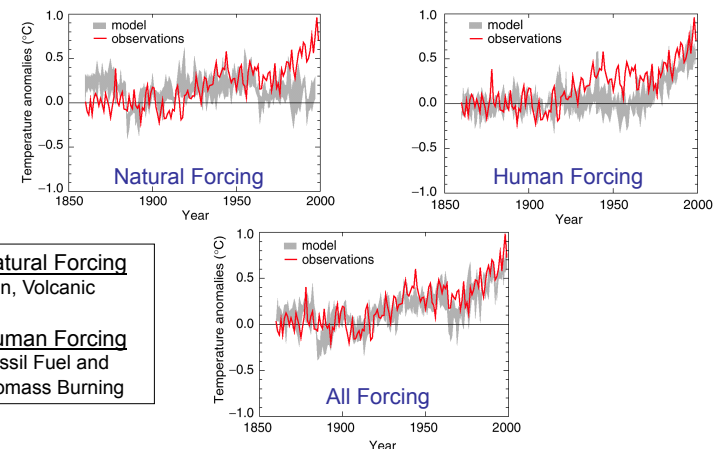

The trend in global temperature is consistent with what is expected due to human forcing (mainly increasing of CO<sub>2</sub>) and too small to be explained by natural forcing or natural variability

## Modeled and Observed Temperature Change 1900-2000

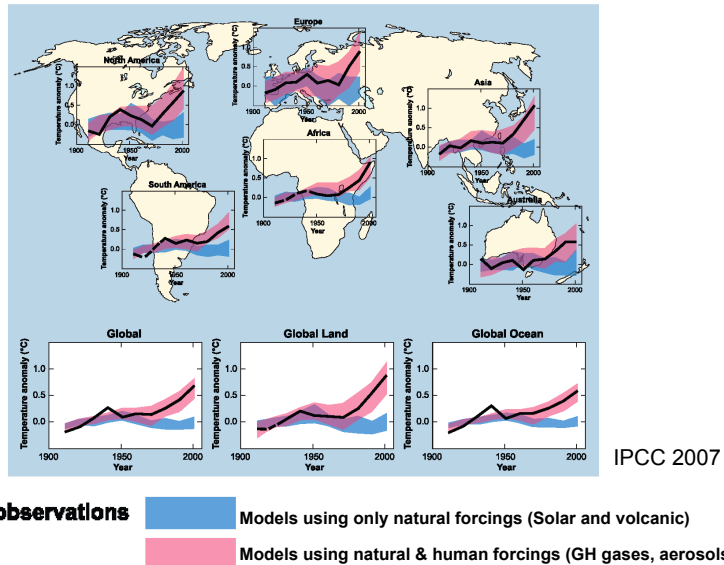

## What models tell us about the 20<sup>th</sup> Century temperature trends

- The trend in global temperature is consistent with what is expected due to human forcing (mainly increasing of CO<sub>2</sub>) and too small to be explained by natural forcing or natural variability
- Other observed trends identified that agree with the response of the models to human forcing:
  - Nighttime temperature is increasing faster than daytime temperature
  - Land is warming faster than ocean
- In the 1950s-1980s: greenhouse warming partially offset by human aerosol loading over land and three large volcanoes

## Climate changes (1900 to 2000) due to human activity

Phenomenon* and direction of trend	Likelihood that trend occurred in late 20th century (typically post 1960)	Likelihood of a human contribution to observed trend <sup>b</sup>
Warmer and fewer cold days and nights over most land areas	Very likely <sup>c</sup>	Likely <sup>d</sup>
Warmer and more frequent hot days and nights over most land areas	Very likely <sup>e</sup>	Likely (nights) <sup>d</sup>
Warm spells/heat waves. Frequency increases over most land areas	Likely	More likely than not <sup>f</sup>
Heavy precipitation events. Frequency (or proportion of total rainfall from heavy falls) increases over most areas	Likely	More likely than not <sup>f</sup>
Area affected by droughts increases	Likely in many regions since 1970s	More likely than not
Intense tropical cyclone activity increases	Likely in some regions since 1970	More likely than not <sup>f</sup>
Increased incidence of extreme high sea level (excludes tsunamis) <sup>g</sup>	Likely	More likely than not <sup>h</sup>

We know this by using models

Virtually certain > 99%  
 Very likely >90%  
 Likely >66%  
 More likely > 50% than not

Probability “based on quantitative analysis or an elicitation of the expert views”

IPCC 2007

## IPCC Conclusions on *observed* Climate Changes:

- Intergovernmental Panel on Climate Change (IPCC)
  - Major reports in 1990, 1996, 2001, 2007 that summarize thousands of peer-reviewed scientific papers
  - A consensus report with contributions from more than 1000 scientists
- Greenhouse gases (carbon dioxide, methane, nitrous oxide) have been increasing since 1750 because of human activity.
- The Earth has warmed by 0.85 ± 0. 2°C since 1900.
- The IPCC concludes:
  - “The balance of evidence suggests a discernible human influence on global climate” (1996)
  - “Most of the observed warming over the past 50 years is likely to have been due to the increase in greenhouse gas concentrations.” (2001)
  - “Most of the observed increase in global average temperature since the mid-20th century is very likely [>90% chance] due to the observed increase in anthropogenic greenhouse gas emissions” (2007)
  - Discernible human influences now extend to other aspects of climate, including ocean warming, continental-average temperatures, temperature extremes and wind patterns” (2007)

### 3. Projections of Climate Change: 2100 and beyond

- The projected forcings
- The projected climate change: 2000 to 2100
  - Global
  - Regional
  - Sea Level
  - Cryosphere
  - Extreme Events
- The long term outlook 2100 - 2300

Projections taken from the most recent consensus report from Intergovernmental Panel on Climate Change.

- Focus on those changes that are “very likely” (i.e., those that are either deemed to have a greater than 90% chance to occur “based on quantitative analysis or an elicitation of the expert views”)

### 3. Projections of Climate Change: 2100 and beyond

- The projected forcings
- The projected climate change: 2000 to 2100
  - Global
  - Regional
  - Sea Level
  - Cryosphere
  - Extreme Events
- The long term outlook 2100 - 2300

### How much Carbon Dioxide will be released into the atmosphere?

The Emission Scenarios

- **The A2 storyline and scenario family** describes a very heterogeneous world. The underlying theme is self reliance and preservation of local identities. Fertility patterns across regions converge very slowly, which results in continuously increasing population. Economic development is primarily regionally oriented and per capita economic growth and technological change more fragmented and slower than other storylines.
- **The A1 storyline and scenario family:** very rapid economic growth, global population that peaks in mid-century and declines thereafter, and the rapid introduction of new and more efficient technologies. Major underlying themes are convergence among regions, capacity building and increased cultural and social interactions, with a substantial reduction in regional differences in per capita income. The A1 scenario family develops into three groups that describe alternative directions of technological change in the energy system.
  - fossil intensive (A1FI), non fossil energy sources (A1T), or a balance across all sources (A1B) (where balanced is defined as not relying too heavily on one particular energy source)
- **The B2 storyline and scenario family:** emphasis is on local solutions to economic, social and environmental sustainability. It is a world with continuously increasing global population, at a rate lower than A2, intermediate levels of economic development, and less rapid and more diverse technological change than in the B1 and A1 storylines. While the scenario is also oriented towards environmental protection and social equity, it focuses on local and regional levels.

Emission scenarios provided by economists, policy makers, etc.

### How much Carbon Dioxide will be released into the atmosphere?

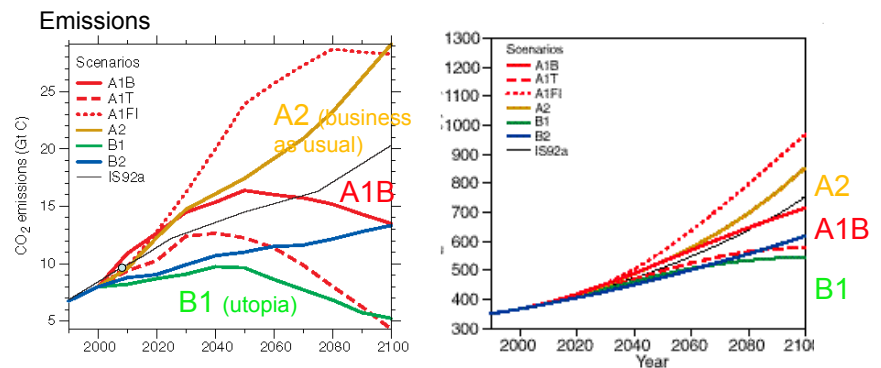

Estimates depends on population and economic projections, future choices for energy, governance/policy options in development (e.g., regional vs. global governance)

### How much GH gas will be released into the atmosphere?

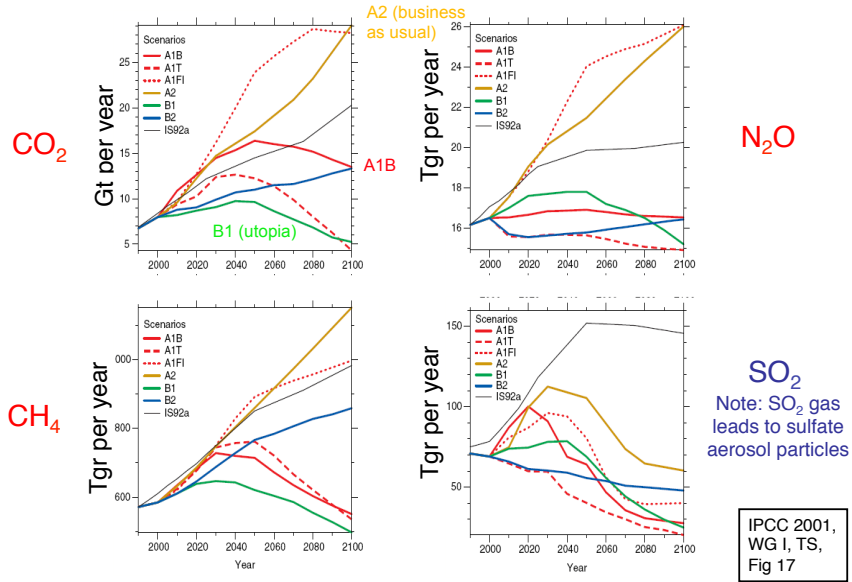

IPCC 2001, WG I, TS, Fig 17

### How much CO<sub>2</sub> do you think will be in the atmosphere?

- ... in 2100 if global emissions stayed the same as today (no population increase or development)
  - Information needed (rounded):
  - Current world-wide emissions 10Gt carbon/yr
  - About 60% of the CO<sub>2</sub> remains in the atmosphere (the rest goes into the ocean and land)
  - There is 835Gt of carbon in the atmosphere today (394ppm)

## How much CO<sub>2</sub> do you think will be in the atmosphere?

- ... in 2100, if global emissions stay the same as today (no population increase or development)
  - Information needed (rounded):
  - Current world-wide emissions 10Gt carbon/yr
  - About 60% of the CO<sub>2</sub> remains in the atmosphere (the rest goes into the ocean and land)
  - There is 835Gt of carbon in the atmosphere today (394ppm)

10 Gt/yr \* 0.6 = 6 Gt/yr stay in atmosphere  
 6 Gt/yr \* 90 years = 540 Gt more carbon in 2100

Total C in atmosphere?  
 835 + 540 = 1375 Gt = 1375/2.12 ppm = 650 ppm  
 (2x preindustrial)

## How much CO<sub>2</sub> do you think will in be the atmosphere?

- ... in 2050, if everyone in the world lived life like an American?
  - 300M people live in the US and we emit 2Gt/yr (including land use)
  - 7B people in the world today, 9B by 2050
  - 60% of what is emitted stays in the atmosphere

The average world population over the next 40 years = 8B

Emission rate: 2 Gt/yr / 0.3B people x 8B people = 53 Gt/yr

Total carbon increase in 38years? 53 Gt/yr x 38 years = 2014 Gt

If 60% stays in atmosphere, then the carbon increase is  
 2014 \* 0.6 = 1210 Gt

So the atmosphere CO<sub>2</sub> concentration is (835 + 1210 )Gt/2.12 Gt/  
 ppm = 965 ppm (3x preindustrial)!

## How much CO<sub>2</sub> do you think will be in the atmosphere?

- If we wanted to stabilize CO<sub>2</sub> concentrations in the atmosphere, how much could the US emit fairly?
  - Information needed:
  - World emissions would must be less than 1Gt/yr

The fraction of the world's people living in the US = 0.3B/7B = 0.042

The fair share of emissions is thus 1Gt \* 0.042 = 0.42 Gt/yr, or about 2% of what we now emit.

## Atmospheric Carbon Dioxide

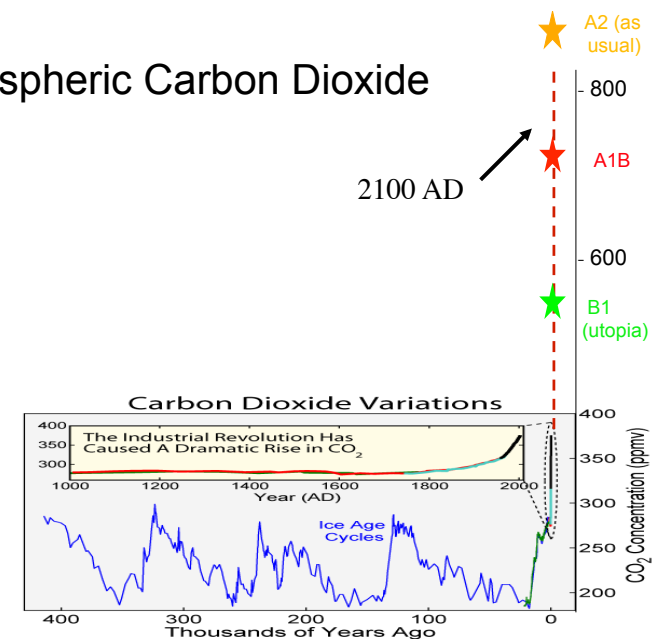

### 3. Projections of Climate Change: 2100 and beyond

- The projected forcings
- The projected climate change: 2000 to 2100
  - Global
  - Regional
  - Sea Level
  - Cryosphere
  - Extreme Events
- The long term outlook 2100 - 2300

### Climate change due to increasing greenhouse gases

Changes that are *very likely\** over the next 100 years include:

- the planet will warm, more so in middle and high latitudes than in the tropics
- the hydrologic cycle will speed up
- the area covered by snow and sea ice in winter will decrease
- the interior of continents will be drier in the summertime
- the sea level will rise
- the surface ocean will become 2-3 times more acidic

These changes will be *much, much* greater than the changes seen over the past 150 years that have been attributed to increased greenhouse gases and aerosols.

*Very likely\** = greater than 90% chance

### Global Warming Projections

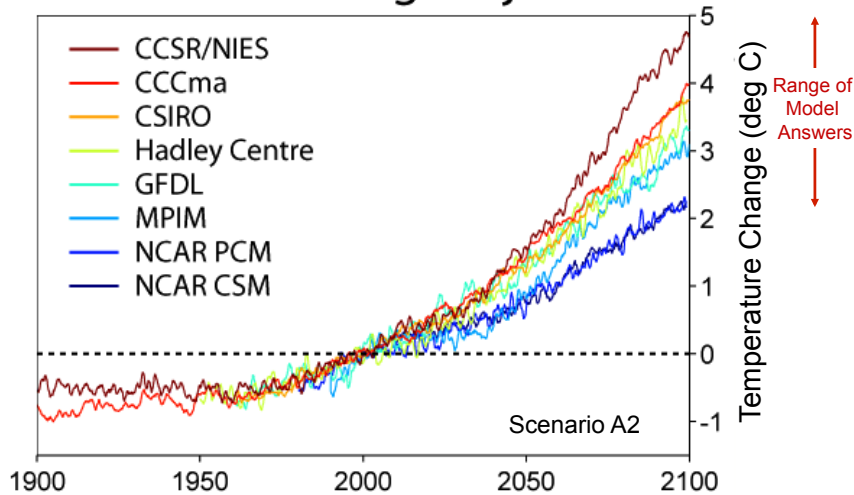

The range in projections is a measure of the uncertainty in the models, given a perfect emission forecast.

### Global Average Temperature Change

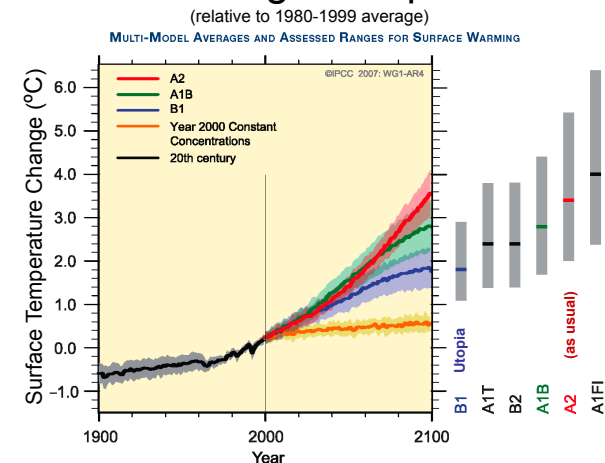

For a mid-range (A1B) emission scenario, model project an global average warming over the next 100 years of 2.8 °C: 3 to 4 times the warming over the past century.

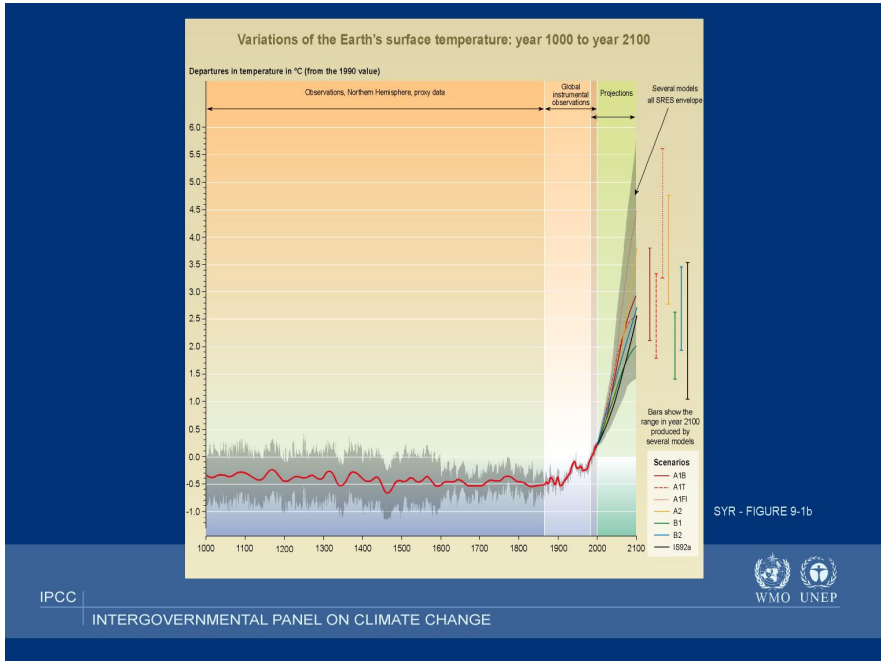

Projected Annual Average Surface Temperature Change: "2080-2099" minus "1980-1999"

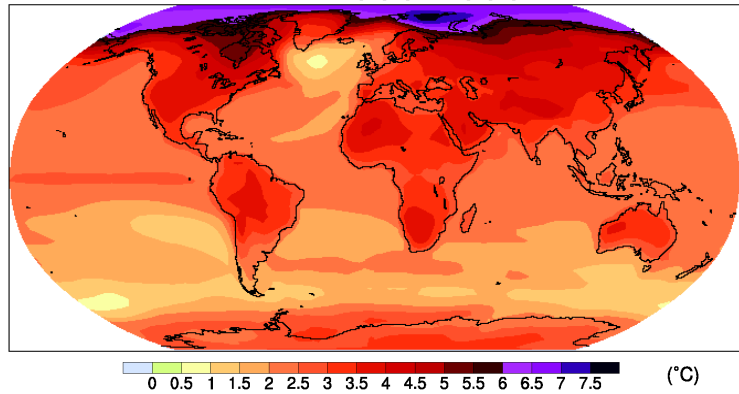

Average of 21 climate models forced by Scenario A1B. Multiply by ~1.2 for A2 and ~0.7 for B1

Zonal (east-west) Temperature Changes: 2090 minus 1990

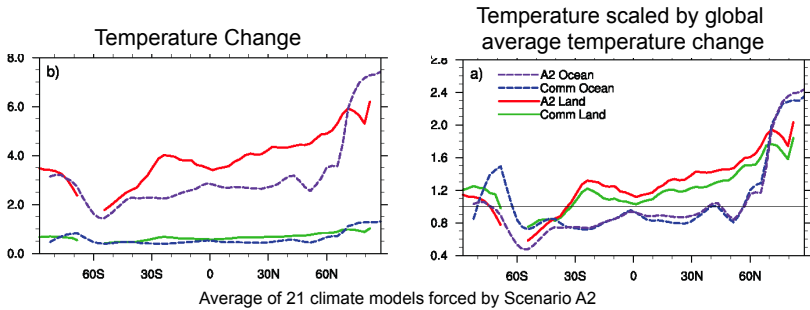

- Land warms more than ocean
- High latitudes warm more than tropics
- "Land minus Ocean" and latitudinal amplification scale with the global average temperature change

Comm = commitment (don't worry about this)

IPCC AR4, Fig 10.6

Zonal (east-west) Temperature Changes: 2090 minus 1990 (scenario A1B)

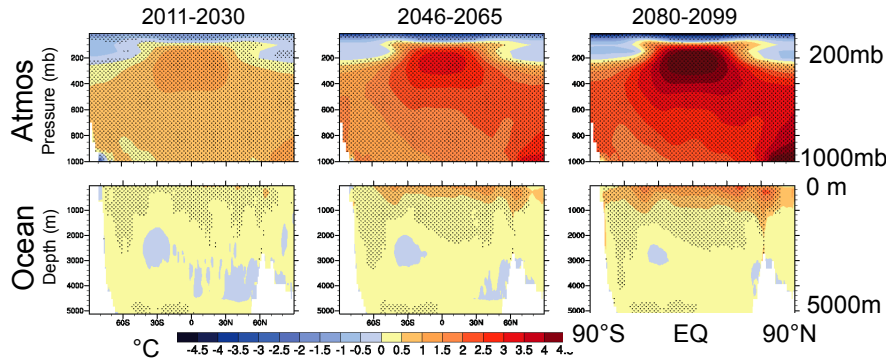

Warming throughout the atmosphere.

Warming in the surface ocean (top 200m), spreading downward over time; ~1000 years to reach bottom.

IPCC AR4, Fig 10.7

Projected Annual Average Surface Temperature Change:

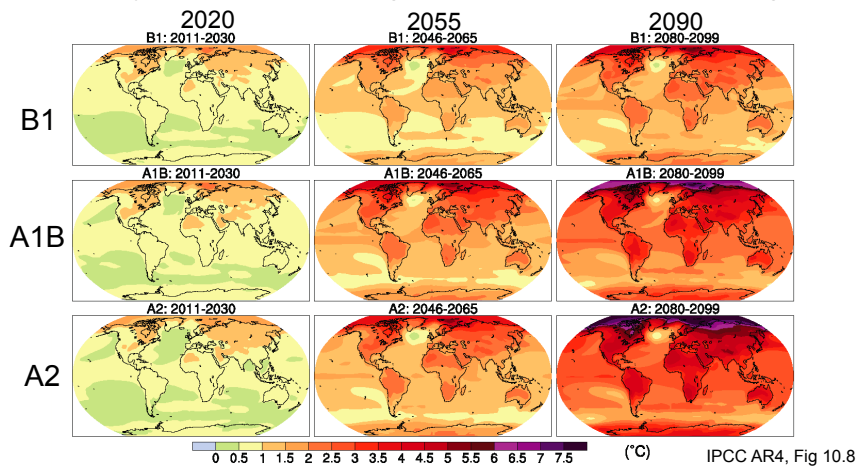

Average of 17/21/21 climate models forced by Scenario A2/A1B/B1.

A2 is about 1.2 times A1B; B1 is about 0.7 times A1B

## Seasonal Cycle of Temperature Changes: “2080-2099” minus “1980-1999”

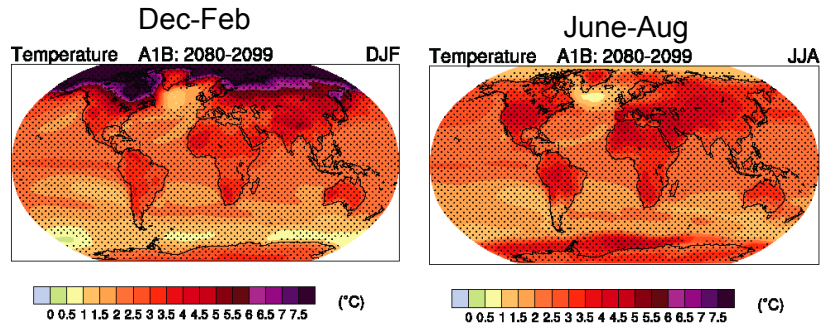

Scenario A1B

More warming in winter than summer (esp. in NH)

Stippling is where the multimodel average change exceeds the standard deviation of the models IPCC AR4, Fig 10.9

## Projected Annual Average Precipitation: “2080-2099” minus “1980-1999”

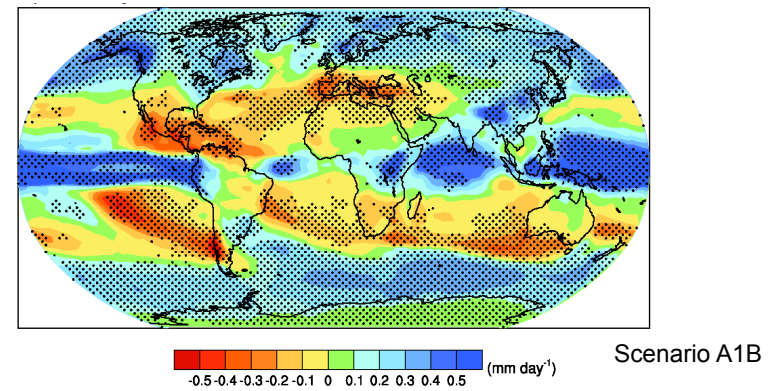

There is a *robust* drying of the subtropics, 20-35°N&S, and a robust wetting of the high latitudes, 45° to pole.

Stippling is where the multimodel average change exceeds the standard deviation of the models

## Projected Soil Moisture Change: “2080-2099” minus “1980-1999”

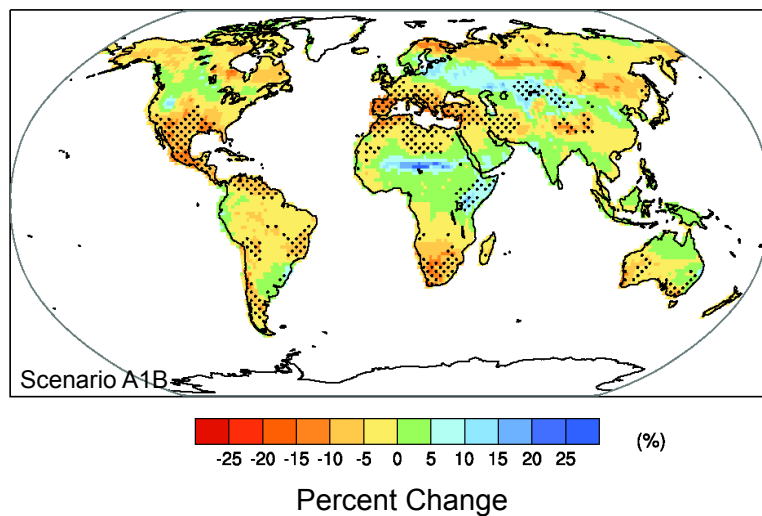

## Changes in Cloudiness and the Diurnal Cycle in Temperature

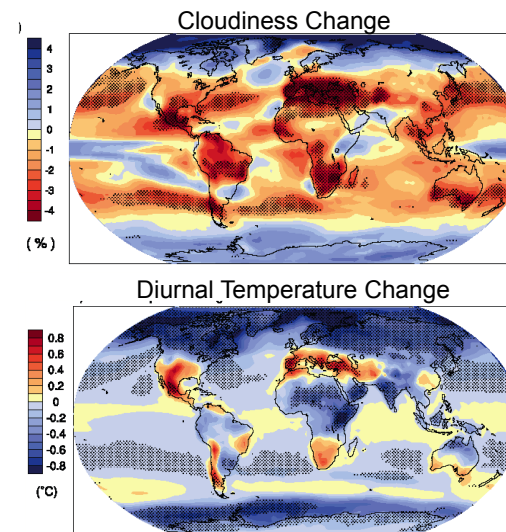

Most models show increasing clouds in high latitudes (cooling negative feedback) and less clouds in tropics

Most models show more warming at night than during day (a decrease in the diurnal temperature range)

Scenario A1B  
IPCC AR4, Fig 10.10,11

## Changes in North American Climate: 2100 minus 2000 AD

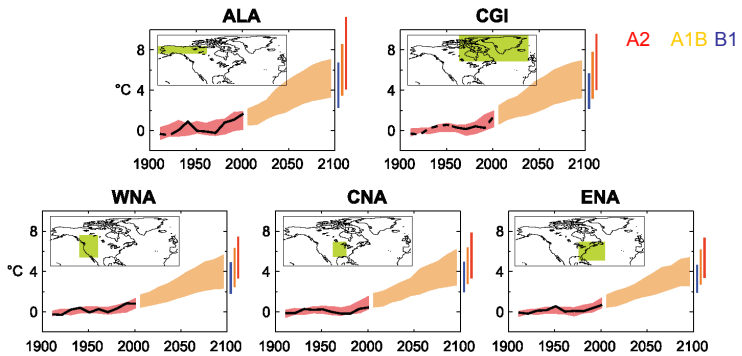

Black line = observed  
 Red shading = model 20<sup>th</sup> Century w/ observed emissions  
 Orange shading = 21<sup>st</sup> Century w/ A1B emissions scenario

IPCC 2007 Fig 11

## Changes in North American Climate: 2100 minus 2000 AD

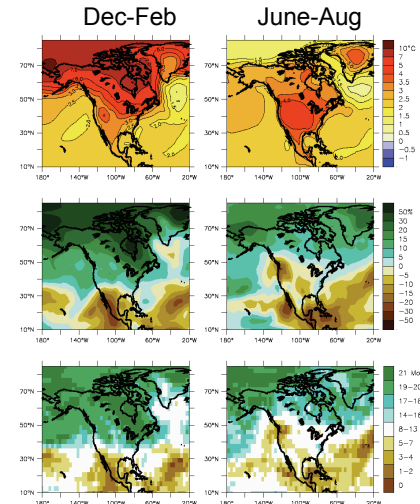

Scenario A1B

Temperature  
(deg C)

Precipitation  
(percent)

# of models  
that agree  
on sign of  
precip

IPCC 2007 Fig 12

## Global average sea level rise (1990 - 2100) for the six SRES Scenarios

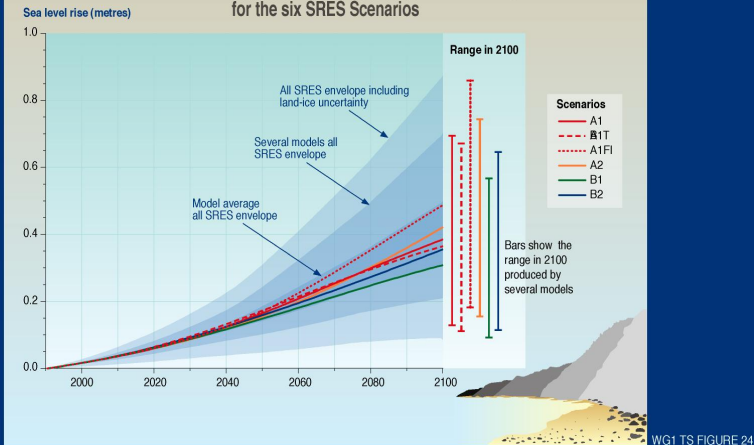

WG1 TS FIGURE 24

## Projected Sea Level Rise: All sources “2080-2100” minus “1980-2000”

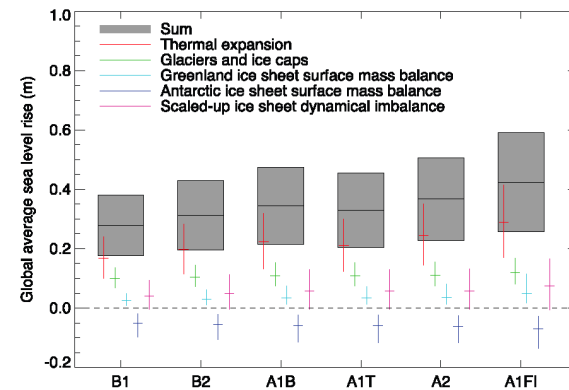

For reference,  
the sea level  
rise from 1961  
to 2003 was  
7.6cm (3 in)

The total assumes current dynamical imbalance in the Antarctic or Greenland ice sheets scales with the temperature increase (a conservative estimate).

IPCC AR4, Fig 10.33

## Sea Ice Thickness

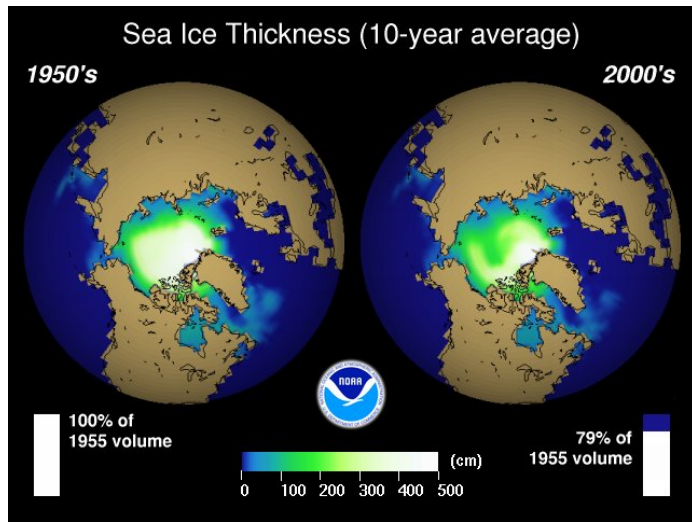

## Sea Ice Thickness

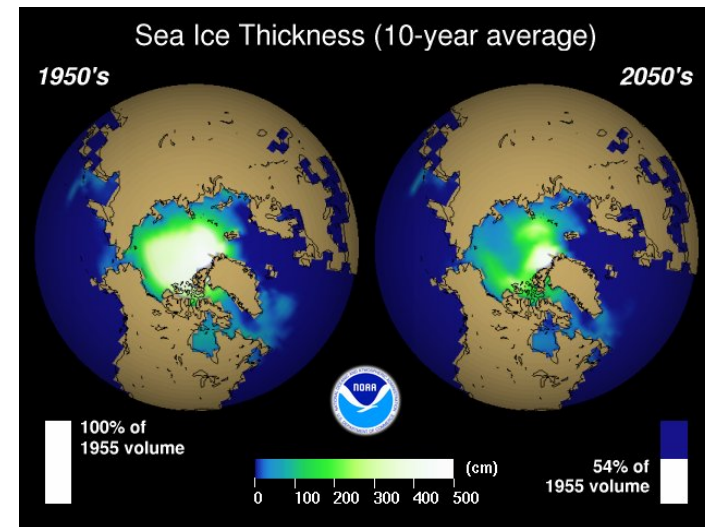

## Projected Sea Ice Extent (in $10^6 \text{ km}^2$ )

"2080-2100" minus "1980-2000"

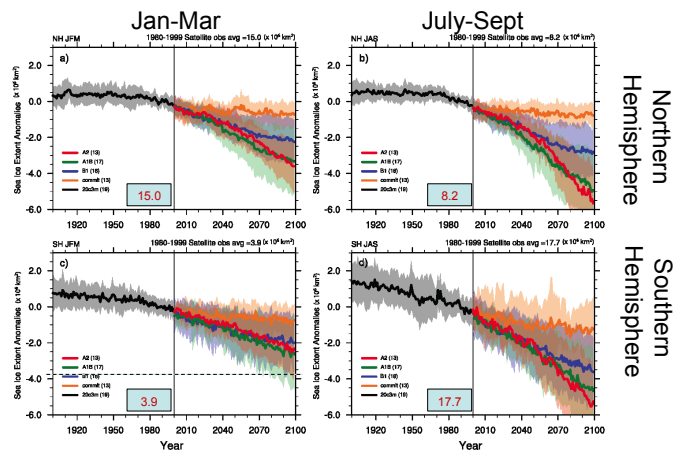

Largest decreases in northern hemisphere

Sea Ice Covered: when 15% of your neighborhood is covered by sea ice

IPCC AR4, Fig 10.13

## Projected Hydrologic Changes:

"2080-2099" minus "1980-1999"

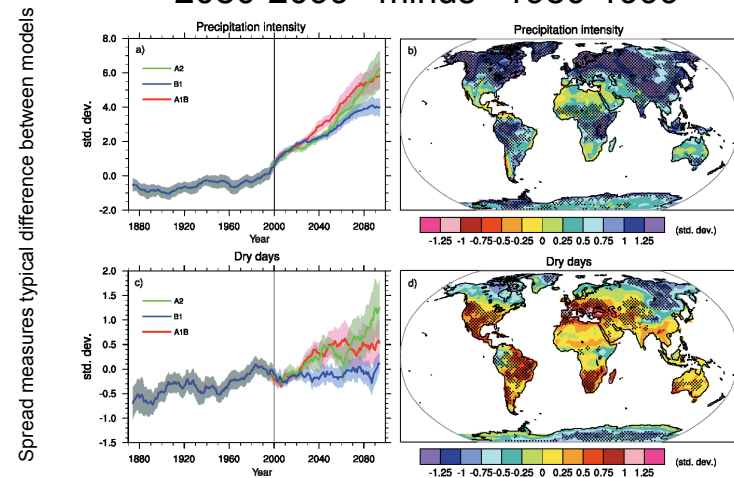

Precip intensity = total annual precip divided by the number of wet days. Results are normalized by the typical year-to-year changes in precip intensity today. So a 1 (1.7) means that a the precip intensity will be the same as that that seen only three times (once) between 1980-1999.

Scenario A1B

## More Extreme Events?

- Increase in hurricane intensity or frequency?
  - Fuel for hurricanes is heat released from condensation of moisture in the air, which increases by ~ 7% per °C of increase in global average temperature. Why?
    - water vapor feedback: there will be 20-25% more water in the air by 2100!
  - Also depend on structure of mean wind
  - In the net, it is hard to tell how hurricane intensity, frequency or paths will change
- Abrupt climate changes?
  - Greenland sliding into the sea? No. Antarctica ?
  - The ocean circulation changing? No.

# Projected Extreme Events: Frosts and Heat Waves

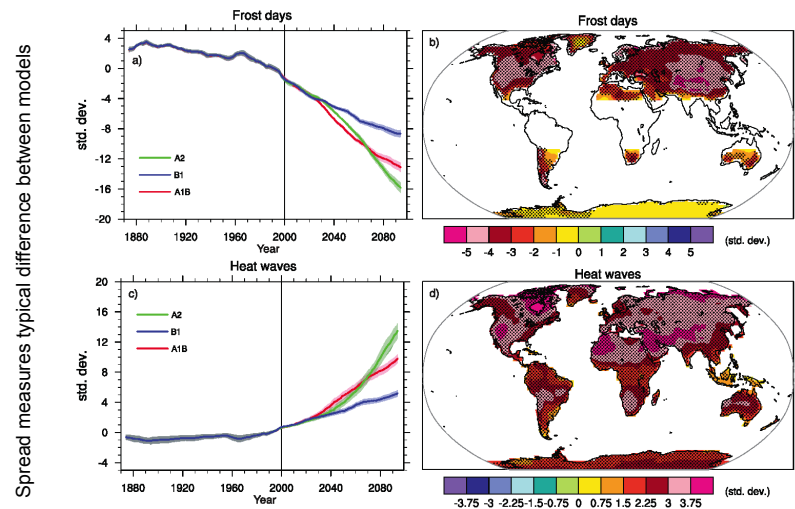

Scenario A1B

IPCC AR4, Fig 10.19

heat waves = the longest period in one year of at least five consecutive days with maximum temperature at least 5C higher than the climatology of the same calendar day

# Climate changes due to human activity

Phenomenon* and direction of trend	Likelihood that trend occurred in late 20th century (typically post 1960)	Likelihood of a human contribution to observed trend*	Likelihood of future trends based on projections for 21st century using SRES scenarios
Warmer and fewer cold days and nights over most land areas	Very likely <sup>a</sup>	Likely <sup>d</sup>	Virtually certain <sup>d</sup>
Warmer and more frequent hot days and nights over most land areas	Very likely <sup>a</sup>	Likely (nights) <sup>d</sup>	Virtually certain <sup>d</sup>
Warm spells/heat waves. Frequency increases over most land areas	Likely	More likely than not <sup>f</sup>	Very likely
Heavy precipitation events. Frequency (or proportion of total rainfall from heavy falls) increases over most areas	Likely	More likely than not <sup>f</sup>	Very likely
Area affected by droughts increases	Likely in many regions since 1970s	More likely than not	Likely
Intense tropical cyclone activity increases	Likely in some regions since 1970	More likely than not <sup>f</sup>	Likely
Increased incidence of extreme high sea level (excludes tsunamis) <sup>g</sup>	Likely	More likely than not <sup>h</sup>	Likely <sup>i</sup>

IPCC 2007

Virtually certain > 99%    Very likely >90%    Likely >66%    More likely than not > 50%

# Changes in Regional Temperature Extremes: 2100 minus 2000 AD

Temperature-Related Phenomena	Projected changes
<b>Change in phenomenon</b>	<b>Projected changes</b>
Higher monthly absolute maximum of daily maximum temperatures (maxTmax) more hot / warm summer days	<b>VL (consistent across model projections)</b> maxTmax increases at same rate as the mean or median <sup>1</sup> over northern Europe, <sup>2</sup> Australia and New Zealand <sup>3</sup> <b>L (fairly consistent across models, but sensitivity to land surface treatment)</b> maxTmax increases more than the median over southern and central Europe, <sup>4</sup> and southwest USA <sup>5</sup> <b>L (consistent with projected large increase in mean temperature)</b> Large increase in probability of extreme warm seasons over most parts of the world <sup>6</sup>
Longer duration, more intense, more frequent heat waves / hot spells in summer	<b>VL (consistent across model projections)</b> Over almost all continents <sup>7</sup> , but particularly central Europe, <sup>8</sup> western USA, <sup>9</sup> East Asia <sup>10</sup> and Korea <sup>11</sup>
Higher monthly absolute maximum of daily minimum temperatures (maxTmin); more warm and fewer cold nights	<b>VL (consistent with higher mean temperatures)</b> Over most continents <sup>12</sup>
Higher monthly absolute minimum of daily minimum temperatures (minTmin)	<b>VL (consistent across model projections)</b> minTmin increases more than the mean in many mid- and high-latitude locations, <sup>13</sup> particularly in winter over most of Europe except the southwest <sup>14</sup>
Higher monthly absolute minimum of daily maximum temperatures (minTmax), fewer cold days	<b>L (consistent with warmer mean temperatures)</b> minTmin increases more than the mean in some areas <sup>15</sup>
Fewer frost days	<b>VL (consistent across model projections)</b> Decrease in number of days with below-freezing temperatures everywhere <sup>16</sup>
Fewer cold outbreaks; fewer, shorter, less intense cold spells / cold extremes in winter	<b>VL (consistent across model projections)</b> Northern Europe, South Asia, East Asia <sup>17</sup> <b>L (consistent with warmer mean temperatures)</b> Most other regions <sup>18</sup>
Reduced diurnal temperature range	<b>L (consistent across model projections)</b> Over most continental regions, night temperatures increase faster than the day temperatures <sup>19</sup>
Temperature variability on interannual and daily time scales	<b>L (general consensus across model projections)</b> Reduced in winter over most of Europe <sup>20</sup> Increase in central Europe in summer <sup>21</sup>

VL  
Very Likely  
> 90%

L  
Likely  
> 66%

IPCC 2007 Tab 11.2

# Changes in Regional Moisture Extremes: 2100 minus 2000 AD

Moisture-Related Phenomena	Projected changes
<b>Phenomenon</b>	<b>Projected changes</b>
Intense precipitation events	<b>VL (consistent across model projections; empirical evidence, generally higher precipitation extremes in warmer climates)</b> Much larger increase in the frequency than in the magnitude of precipitation extremes over most land areas in middle latitudes, <sup>22</sup> particularly over northern Europe, <sup>23</sup> Australia and New Zealand <sup>24</sup> Large increase during the Indian summer monsoon season over Arabian Sea, tropical Indian Ocean, South Asia <sup>25</sup> Increase in summer over south China, Korea and Japan <sup>26</sup>
Intense precipitation events	<b>L (some inconsistencies across model projections)</b> Increase over central Europe in winter <sup>27</sup> Increase associated with tropical cyclones over Southeast Asia, Japan <sup>28</sup> <b>Uncertain</b> Changes in summer over Mediterranean and central Europe <sup>29</sup> <b>L decrease (consistent across model projections)</b> Iberian Peninsula <sup>30</sup>
Wet days	<b>L (consistent across model projections)</b> Increase in number of days at high latitudes in winter, and over northwest China <sup>31</sup> Increase over the Inter-Tropical Convergence Zone <sup>32</sup> Decrease in South Asia <sup>33</sup> and the Mediterranean area <sup>34</sup>
Dry spells (periods of consecutive dry days)	<b>VL (consistent across model projections)</b> Increase in length and frequency over the Mediterranean area <sup>35</sup> , southern areas of Australia, New Zealand <sup>36</sup> <b>L (consistent across model projections)</b> Increase in most subtropical areas <sup>37</sup> Little change over northern Europe <sup>38</sup>
Continental drying and associated risk of drought	<b>L (consistent across model projections; consistent change in precipitation minus evaporation, but sensitivity to formulation of land surface processes)</b> Increased in summer over many mid-latitude continental interiors, e.g., central <sup>39</sup> and southern Europe, Mediterranean area, <sup>40</sup> in boreal spring and dry periods of the annual cycle over Central America <sup>41</sup>

VL  
Very Likely  
> 90%

L  
Likely  
> 66%

IPCC 2007 Tab 11.2

## Changes in Regional Storminess Extremes: 2100 minus 2000 AD

Tropical Cyclones (typhoons and hurricanes)	
Change in phenomenon	Projected changes
Increase in peak wind intensities	L (high-resolution AGCM and embedded hurricane model projections) Over most tropical cyclone areas <sup>12</sup>
Increase in mean and peak precipitation intensities	L (high-resolution AGCM projections and embedded hurricane model projections) Over most tropical cyclone areas <sup>13</sup> South, <sup>14</sup> East <sup>15</sup> and southeast Asia <sup>16</sup>
Changes in frequency of occurrence	M (some high-resolution AGCM projections) Decrease in number of weak storms, increase in number of strong storms <sup>17</sup> M (several climate model projections) Globally averaged decrease in number, but specific regional changes dependent on sea surface temperature change <sup>18</sup> Possible increase over the North Atlantic <sup>19</sup>
Extratropical Cyclones	
Change in phenomenon	Projected changes
Changes in frequency and position	L (consistent in AOGCM projections) Decrease in the total number of extratropical cyclones <sup>20</sup> Slight poleward shift of storm track and associated precipitation, particularly in winter <sup>21</sup>
Change in storm intensity and winds	L (consistent in most AOGCM projections, but not explicitly analysed for all models) Increased number of intense cyclones <sup>22</sup> and associated strong winds, particularly in winter over the North Atlantic, <sup>23</sup> central Europe <sup>24</sup> and Southern Island of New Zealand <sup>25</sup> More likely than not
Increased wave height	L (based on projected changes in extratropical storms) Increased occurrence of high waves in most mid-latitude areas analysed, particularly the North Sea <sup>27</sup>

VL  
Very Likely  
> 90%

L  
Likely  
> 66%

M  
Medium  
Confidence

IPCC 2007 Tab 11.2

## Ocean Acidification

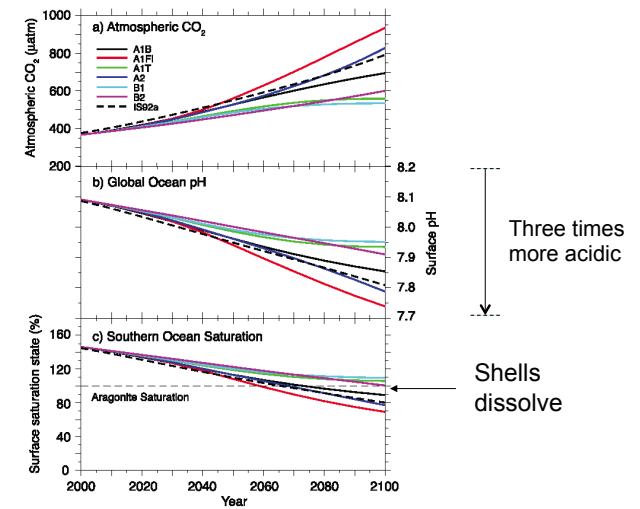

IPCC AR4, Fig 10.24

## 3. Projections of Climate Change: 2100 and beyond

- The projected forcings
- The projected climate change: 2000 to 2100
  - Global
  - Regional
  - Sea Level
  - Cryosphere
  - Extreme Events
- The long term outlook 2100 - 2300

## Global Annual Average Surface Temperature

Values beyond 2100 *assume* stabilized GH gas concentrations\*

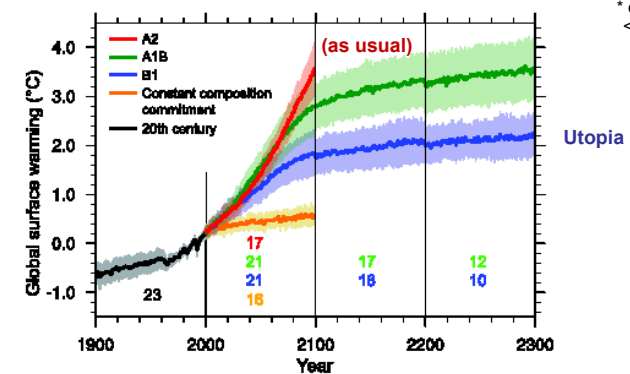

Referenced to the 1980-1999 Average Temperature  
Solid lines: average of all models used. The number of models used depends on the emission scenario; shaded area is the standard deviation of the models. Gold curve is for **Zero** emissions beyond 2100.

## The long term outlook: 2000-3000AD

If we stop *all* human CO<sub>2</sub> emissions in 2100, how long will it take to reach the pre-industrial climate\*?

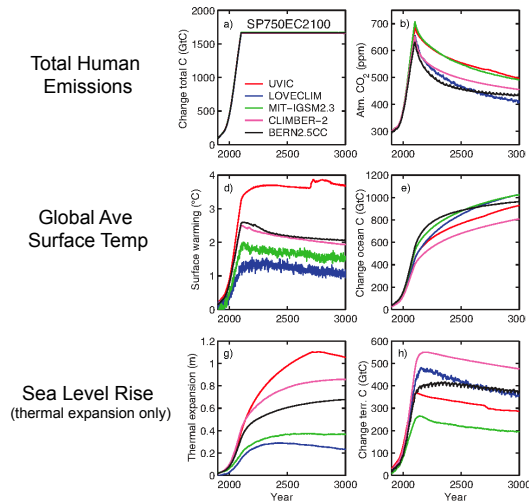

CO<sub>2</sub> in atmosphere peaks at 750 in 2100

CO<sub>2</sub> in ocean increases rapidly until ~2200, then slowly for 1000+ years

CO<sub>2</sub> in land biomass increases rapidly until ~2200, then slowly declines

## The VERY long term adjustment

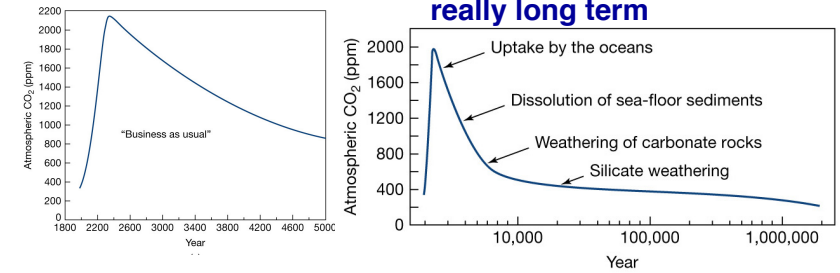

The atmospheric CO<sub>2</sub> concentration - and hence climate - returns to near pre-industrial (PI) levels by 10,000 yrs

Almost all of the human emissions of CO<sub>2</sub> end up in the ocean

Kump et al. (2003), T Earth System, Box Fig 13-2

How long would forcing by humans last if we suddenly stopped emitting everything?

- Carbon Dioxide
  - About 1/2 removed in **1000 years** (absorbed in the deep ocean)
  - Most gone by 10,000 years
- Methane
  - About 70% removed in 10 years (absorbed into soil)
  - Most gone by 20 years
- CFCs
  - 50 to 20,000 years, depending on compound
- Aerosols
  - In troposphere, about 5 days
  - In stratosphere, about 2 years

**Editorial note:** Carbon credits for reducing methane will, at best, waste money. It will likely lead to *more* CO<sub>2</sub> in the atmosphere.

## The long term outlook: 2000-3000AD

If -- in the next 200-300yrs or so-- we reduce CO<sub>2</sub> emissions to a small constant rate (<10% of today's emission), the climate will eventually equilibrate. How long will it take to reach the new equilibrium?

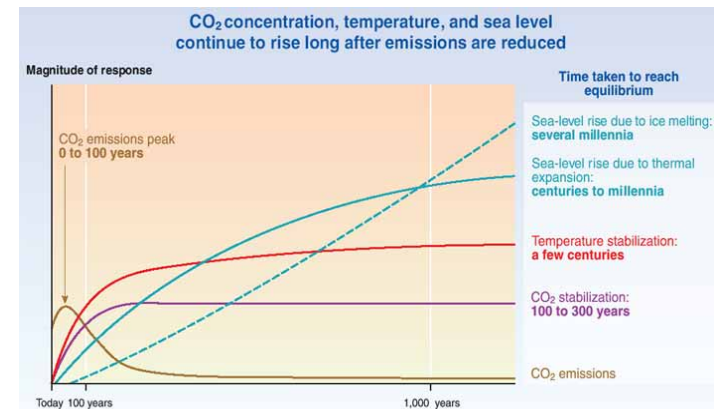

# Global Warming: Science, Projections and Uncertainties

An overview of the basic science

1. A Brief History of "Global Warming"
2. Climate Change: 1850-2007
3. Projections of Climate Change: 2100 and beyond
4. What's new in Climate Science?
5. Conclusions

## 4. What's new? A better quantification of the spread in the model response and reasons for the spread

*Climate Sensitivity: the change in global temperature for a doubling of carbon dioxide*

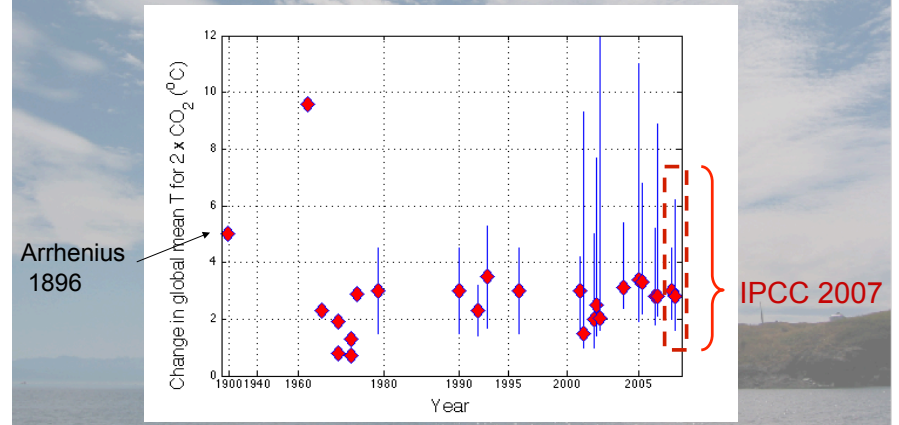

## Why is there uncertainty in the climate models? Mainly weakness is modeling clouds!

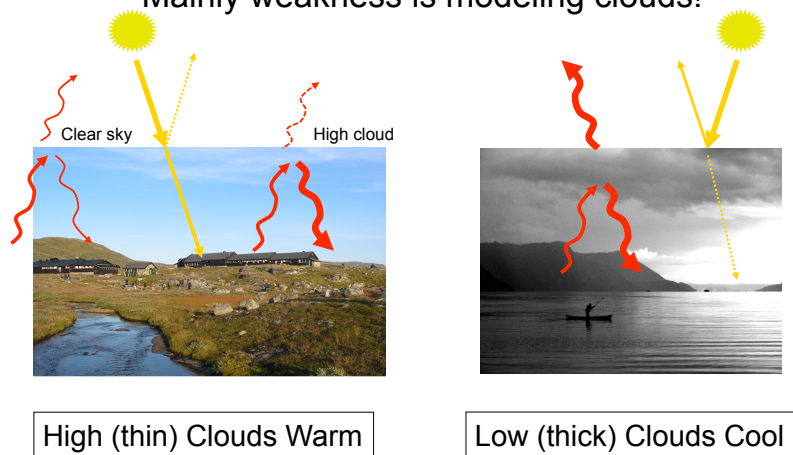

In today's climate, *the net effect of clouds is to cool the planet* (albedo effect wins over greenhouse effect)

## Clouds and Climate



## What happens when you double atmos CO<sub>2</sub>?

- With no feedbacks: increase temp by 1.2°C
- With all feedbacks (mainly water vapor) *except clouds*: increase by +1.9°C +/- 0.15°C
- With all feedbacks (*incl. clouds*): +3.2°C +/- 0.7°C

Clouds are a major positive feedback (ie, clouds cool less than today when CO<sub>2</sub> is doubled), but amplitude is uncertain.

More of these .... ...and/or... ... less of these.



Clouds are the major source of the differences between models (i.e., for the uncertainty in the projections of the climate response to increasing CO<sub>2</sub>).

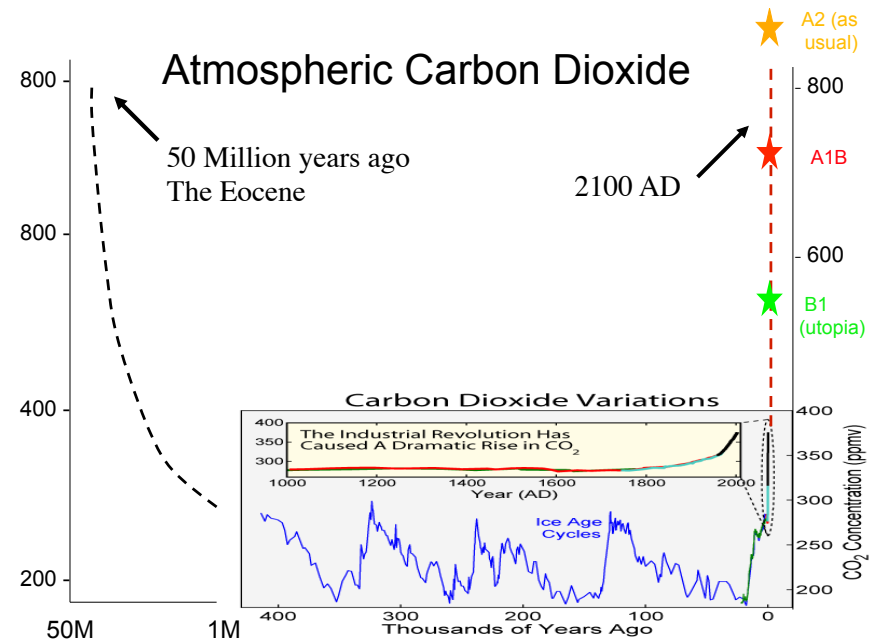

In 100 years, the atmospheric CO<sub>2</sub> will reach 500-1000 ppm, which was last experienced during the EOCENE (55 to 36 million years ago)



The Eocene climate was warm, even at high latitudes:

- palm trees flourished in Wyoming and Antarctica was a pine forest
- crocodiles lived in the Arctic
- deep ocean temperature was 55°F (today it is ~35°F)
- sea level was at least 300 feet higher than today

\* Climate models with mid-range climate sensitivity simulate an Eocene that is much too cold compared to the fossil records

## The Expected Distribution of Climate Sensitivity

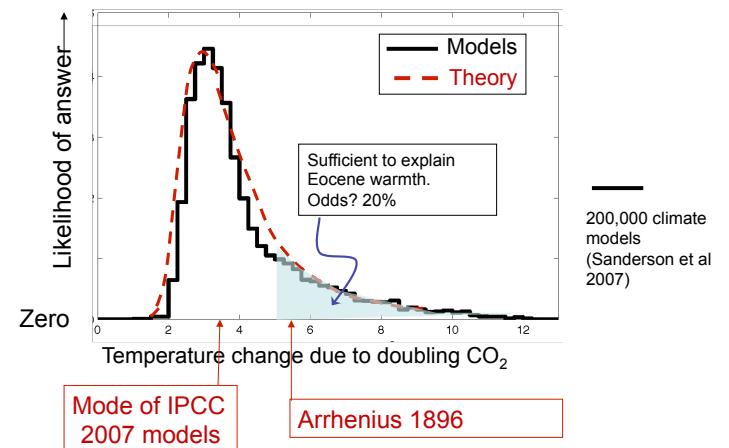

Roe and Baker (2007) provide a simple theory for estimating the *expected* distribution of model responses due to model uncertainty.

*Implication of the fossils: true response is ~1.7x IPCC mean.*

## Summary: Climate in the 20<sup>st</sup> Century

- Greenhouse gases have increased over the past 100 years to do human activity, and this has caused the climate to change:
  - Warming -- more over continents than oceans; more in high latitudes than in tropics; more at night than day
  - fewer frost days per year; more extreme warm days, etc.
  - decreased sea ice extent and volume
  - higher sea levels; more acidic ocean
- The warming would have been much greater, if not for the increase in atmospheric aerosols due to burning of coal and atmospheric biomass

From IPCC 2007

## Summary: Climate in the 21<sup>st</sup> Century

- The climate is projected to change over this century because of human-induced changes in greenhouse gases (CO<sub>2</sub>, CH<sub>4</sub>, SO<sub>2</sub>, etc)
- The global, annual averaged temperature will likely increase by ~ +3°C [2.4 to 6.4°C]
  - Only the high-end estimate is consistent with the geological records
- The uncertainty in the climate projections is roughly equally due to
  - Uncertainty in emissions
  - Uncertainty in models

From IPCC 2007

## Summary: Climate in the 21<sup>st</sup> Century (cont)

• Warming will not be uniform in space or time. It is *very likely* that

- Warming -- more over continents than oceans; more in high latitudes than in tropics; more in winter than summer, more at night than day
- Fewer frost days per year
- More extreme warm days and nights

• Other climate changes that are *very likely*\* over the next 100 years include:

- the hydrologic cycle will speed up
- the area covered by snow and sea ice will decrease
- the subtropics will be drier (less precip/more evaporation)
- the sea level will rise
- The upper ocean will become twice as acidic.

(\* very likely: defined by the IPCC as greater than 90% chance) From IPCC 2007

## Summary: Climate in the 21<sup>st</sup> Century (cont)

- The changes over the next 100 years will be much, much greater than the changes seen over the past 150 years that have been attributed to increased greenhouse gases and aerosols.
- The rate of change is 100 - 1000 times faster than nature
- The changes in climate will have a significant and increasing effect on temperature, precipitation, snow pack, river flows (amount and timing), and soil moisture.
  - > **agriculture**, fisheries, forestry, aquaculture ...
  - > ecosystems and biodiversity
  - > flood control policy, hydropower, vector borne diseases, ...
- We now understand the range in the warming projected for 2100 by the various models, and can better quantify the likelihood of a very large warming (compared to average warming, used by IPCC)

From IPCC 2007

## Pacific Northwest Climate (~1920 - 2100)

- Late 20<sup>th</sup> Century Trends
  - Temperature
  - Precipitation
  - Runoff & Stream flow
  - Snow pack
- Projections of Future Climate Changes
  - Temperature
  - Precipitation
  - Runoff & Stream flow
  - Snow pack
- Impacts of Future Climate Changes
  - Water supply: hydropower, drinking water, salmon,
  - Temperature: less heating in winter, more cooling in summer (power supply)
  - Forest Fires
  - Ecology

Globally warming will become highly significant in our region by the end of the century

## Pacific Northwest Climate (~1920 - 2100)

- Late 20<sup>th</sup> Century Trends
- Projections of Future Climate Changes
  - Temperature
  - Precipitation
  - Runoff & Stream flow
  - Snow pack
- Impacts of Future Climate Changes

Change 1990s to 2020s DJF 2-m Temperature (F)

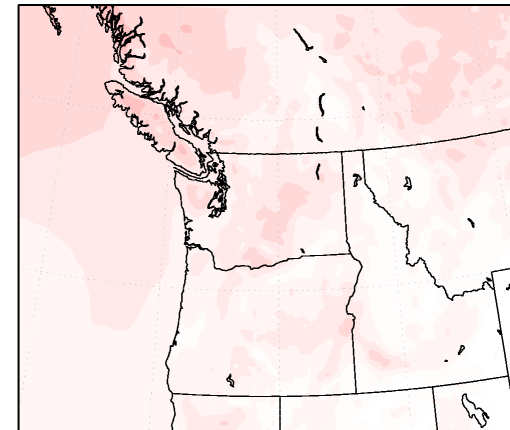

These maps are in °F

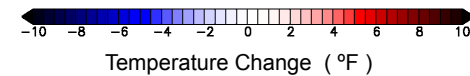

Change 1990s to 2050s DJF 2-m Temperature (F)

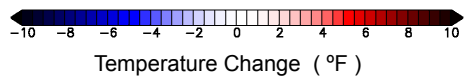
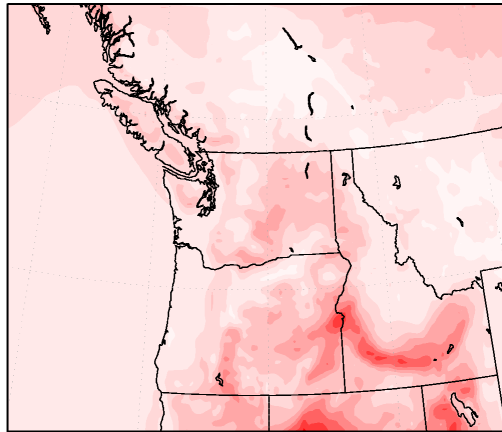

Change 1990s to 2090s DJF 2-m Temperature (F)

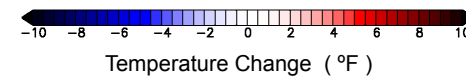
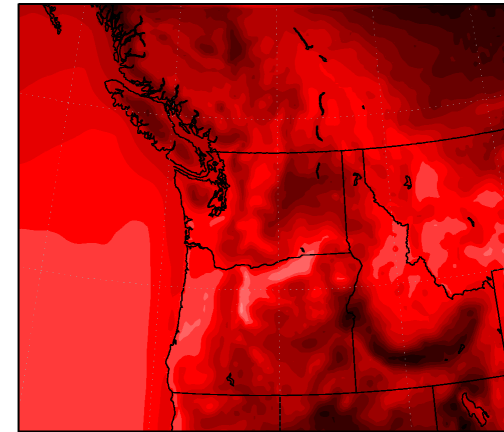

## 21<sup>st</sup> Century PNW Temperature and Precipitation Change Scenarios

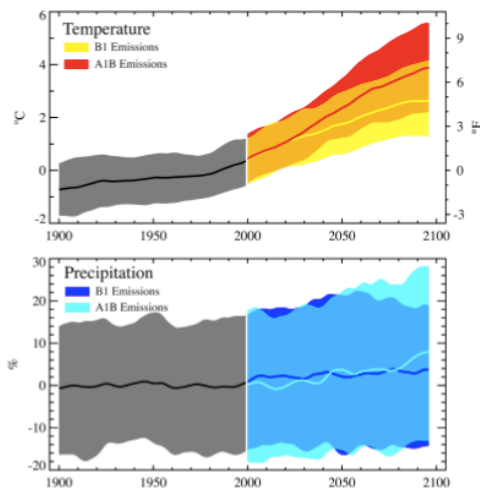

- Projected changes in temperature are large compared to historic variability
- Changes in annual precipitation are generally small compared to past variations, but some models show large seasonal changes (**wetter autumns and winters and drier summers**)

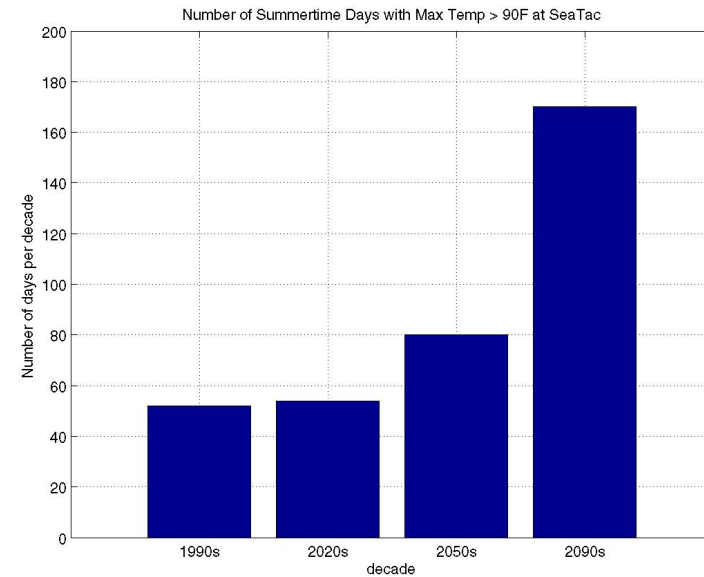

# A robust impact of climate warming: less snow

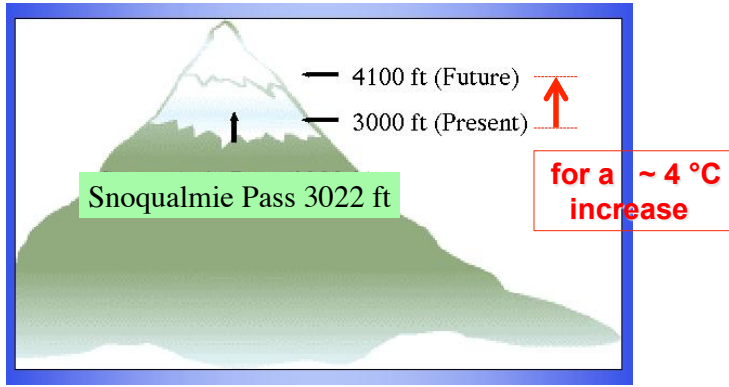

for a ~4°C warming, snow level goes up  
 $4C \times 1km / 6.5C = 600m = 2000 ft$

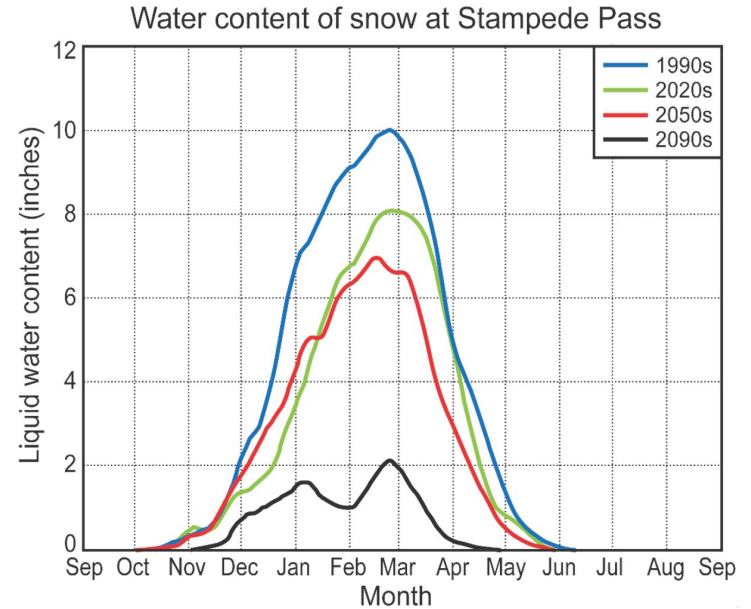

## Main Impact: Less Snow

### Less snow stored, earlier melt:

- ☁ Snow level higher: less precip stored as snow in winter
- \* Mid-elevation “transient snow” basins most sensitive

Changes in Simulated April 1 Snowpack for the Cascade Range in WA and OR

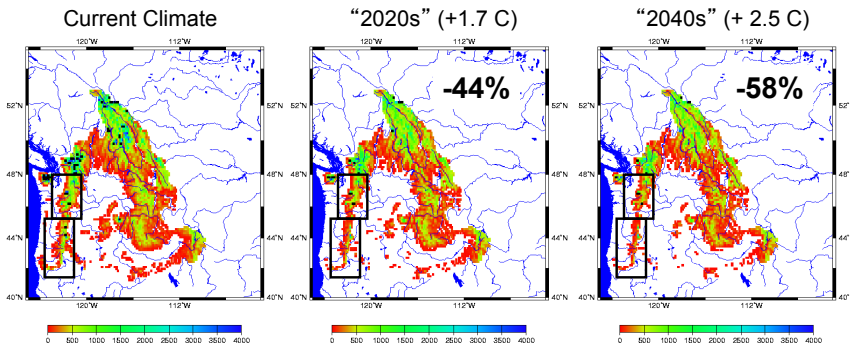

These changes contribute to...

1. Higher winter flows (incr. winter flood risk)
2. Earlier and lower peak flows (longer dry season, less water for salmon)
3. Lower summer flows

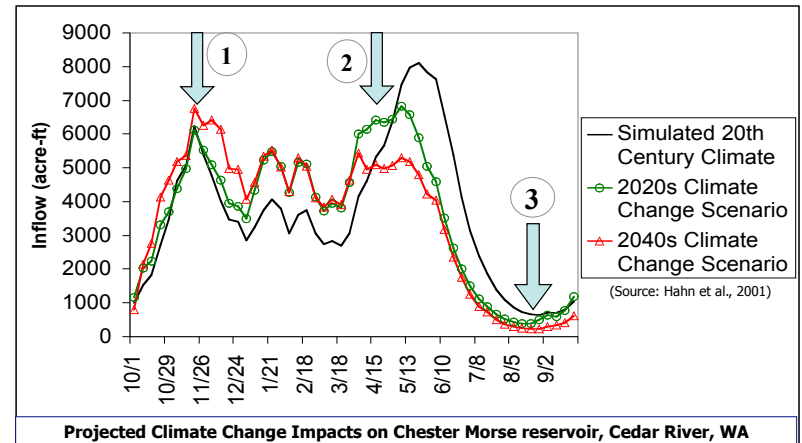

# Pacific Northwest Climate (~1920 - 2100)

- Late 20<sup>th</sup> Century Trends
- Projections of Future Climate Changes
- Impacts of Future Climate Changes
  - Water supply: hydropower, drinking water, salmon,
  - Temperature: less heating in winter, more cooling in summer (power supply)
  - Forest Fires
  - Ecology

## Hydropower and Drinking Water

- Less water stored in reservoirs in winter (flooding protection) & less water stored in summer snow pack
- Hence, less water in reservoirs in summer for ...
  - Irrigation of crops (eastern WA)
  - Drinking and residential water use (western WA)
  - Hydropower (for home and industry) that will be in greater demand in summer (air conditioning)
  - Less water in streams for fish

## A warmer climate and flooding

- At mid-elevations, more precipitation will fall as rain and less as snow
- a warmer atmosphere holds more moisture: theory and climate models suggest an increased *intensity* of precipitation
  - This combination points to an increased frequency of river flooding in fall and winter



## Increased stress on salmon

- **Low flows+warmer water = increased pre-spawn mortality for summer run and stream-type salmon and steelhead**
  - Clear indications for increased stress on Columbia Basin sockeye, summer steelhead, summer Chinook, and Lake Washington sockeye and Chinook, and coho and steelhead more generally



Harley Soltis/Seattle Times

- **Increased winter flooding in transient rain+snow watersheds**
  - a limiting factor for egg-fry survival for fall spawners + coho and steelhead parr overwinter survival in high-gradient reaches

## Change in Frequency of Large Fires for a 1°C global average temperature change

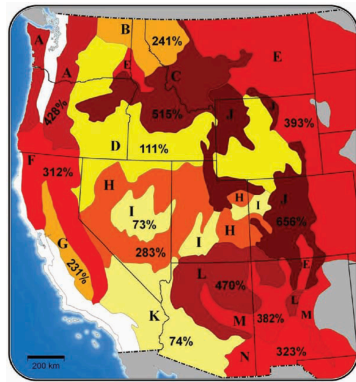

A - Cascade Mixed Forest	H - Intermountain Semi-Desert / Desert
B - Northern Rocky Mt. Forest	I - Nev.-Utah Mountains-Semi-Desert
C - Middle Rocky Mt. Steppo-Forest	J - South Rocky Mt. Steppo-Forest
D - Intermountain Semi-Desert	K - American Semi-Desert and Desert
E - Great Plains-Palouse Dry Steppe	L - Colorado Plateau Semi-Desert
F - Sierran Steppo-Mixed Forest	M - Ariz.-New Mex. Mts. Semi-Desert
G - California Dry Steppe	N - Chihuahuan Semi-Desert

Littell et al. (2009); in Solomon et al (2010)

Percent increase (relative to 1950-2003) in median annual area burned for ecoregions of the West with a 1°C increase in global average temperature. Changes in temperature and precipitation were aggregated to the ecoregion level using the suite of models in the CMIP3 archive.

## Ecosystem thresholds: the case of the Mountain Pine Beetle

- a massive outbreak of the mountain pine beetle in BC has killed trees containing 100 billion board feet of lumber (approx. 9 years of harvest)
  - A recent lack of low killing temperatures (< -10°F) has increased over-winter survival rates



beetle killed pines in BC

Photos from <http://www.for.gov.bc.ca>

## Climate change impacts on Washington's forests

- **CO<sub>2</sub> fertilization**
  - A transient boost
- **A longer dry season**
  - reduced regeneration, increased vulnerability to fires and pests (except in especially cool-wet locations)
- **shifts in species ranges**
  - subalpine forests “invading” alpine meadows; a northward march--or a loss--of species?



## What Can We Expect?

### Short term (1-2 decades):

- Increasing drought mortality
- Increasing area burned and fire severity
- Increases in area of insect mortality
- Increases in fire frequency
- Forest adaptation to native insect disturbance, but exotics...?
- Disturbance (insects, fire, or both) becomes the main factor determining which forest management actions are *possible*



### Long term (3-?? decades):

- Changes in forest communities, especially after disturbance from harvest, fire and/or insects
- Visible changes in forest ecosystem productivity



## Bottom Line

- Global warming is real and a major concern in the PNW
- Since the Puget Sound is downstream of the Pacific, global warming's effects will be slightly slower and delayed here compared to interior of continental US (ie, east of the Cascades)
- By the end of the century, the local impacts will be profound

## What did we do in the Fall of 2012?

**Week 1 Introduction;** Origin of the Earth's Atmosphere; Atmosphere composition today

**Week 2** Heat and Temperature; Heat Forms and Transport; Radiation; Concepts in EM Radiation; Solar Radiation and the Earth; Albedo

**Week 3** Energy Balance; Greenhouse gases and the Greenhouse Effect; Seasonal Temperature Cycles

**Week 4** Seasonal and diurnal temperature cycles; Pressure; Hydrostatic balance

**Week 5** Coriolis effect and geostrophic wind

**Week 6** Jet streams; Midterm; General Circulation of the Atmosphere

**Week 7** General Circulation of the Atmosphere (cont); The Role of Mountains in Climate; Ice Ages and how we know they happened; Milankovitch theory

**Week 8** Human Induced Changes in Greenhouse Gases and their Impact on Climate (the 20th Century); Climate models; Climate variability and forced climate change defined.

**Week 9** Climate variability and forced climate change (cont); ENSO, volcanic forcing, Solar forcing, human forcing

**Week 10** Projected Climate Change (today to 2100 and beyond)

**Week 11** Climate Change in the Pacific Northwest; Geoengineering

1/3

2/3

## Climate Engineering (aka Geoengineering)

- What is it?
- Why do it?
  - Large changes ahead (including some unforeseen)
- How do we stop the climate from changing without reducing CO<sub>2</sub> emissions by climate engineering?
  - Take CO<sub>2</sub> out of the atmosphere (unlikely)
  - Reduce sunlight to counter increased CO<sub>2</sub> due to human activity
- General pros and cons of climate engineering

## Climate Engineering (aka Geoengineering)

- What is it?
- Why do it?
  - Large changes ahead (including some unforeseen)
- How do we stop the climate from changing without reducing CO<sub>2</sub> emissions by climate engineering?
  - Take CO<sub>2</sub> out of the atmosphere (unlikely )
  - Reduce sunlight to counter increased CO<sub>2</sub> due to human activity
- General pros and cons of climate engineering

## Climate engineering



“The intentional, large-scale manipulation of the environment.” [David Keith]

“The deliberate modification of Earth’s environment on a large scale ‘to suit human needs and promote habitability.’” [wikipedia.org]

## Climate Engineering: a brief history

- **1974:** Mikhail Budyko proposed injecting sulfur dioxide in the stratosphere to create sulfate droplets that would scatter sunlight and cool the earth
- **Early 1990' s:** Edward Teller\* and collaborators proposed putting designer particles into the stratosphere to deflect sunlight.  
\*Father of the H-bomb, principal architect of Star Wars Defense Initiative, inspiration for Dr. Strangelove
- **1992:** The National Academy of Sciences issues a detailed study on geoengineering options for avoiding climate change, which includes evaluation of the science and a cost-benefit analysis for each option.
- **2006:** Paul Crutzen (Nobel Prize winner for his work on the Ozone Hole) re-discovers Budyko' s plan. He argues persuasively that the scope and speed of climate changes due to increasing CO<sub>2</sub> -- coupled with the lack of any progress on mitigation -- requires this geoengineering solution be seriously considered.

## Why must we consider Climate Engineering?

- The projected climate changes are large and fast enough to cause large disruptions and distress in the global economy, society and in the environment.
  - World food production: 20% reduction in global grain production by 2050 due to increased temperature alone
  - Ecosystem changes are underway: biodiversity is being lost at an unprecedented rate

## Climate Engineering (aka Geoengineering)

- What is it?
- Why do it?
  - Large changes ahead (including some unforeseen)
- How do we stop the climate from changing without reducing CO<sub>2</sub> emissions by climate engineering?
  - Take CO<sub>2</sub> out of the atmosphere (unlikely )
  - Reduce sunlight to counter increased CO<sub>2</sub> due to human activity
- General pros and cons of climate engineering

## Why must we consider Climate Engineering?

- To avoid large increases in atmospheric CO<sub>2</sub> requires huge changes in current technological systems (power, transport, buildings), creates winners and losers, and presents deep challenges to equity. A very tall order.
- The potential for unanticipated climate catastrophes
  - Sea level: the Antarctic ice shelves may become unstable; could raise global sea level abruptly by meters.
  - Temperature increase: methane released to atmosphere by melting permafrost could double atmospheric CO<sub>2</sub>.
- The Fat Tail of Climate

# The Fat Tail of Climate Sensitivity

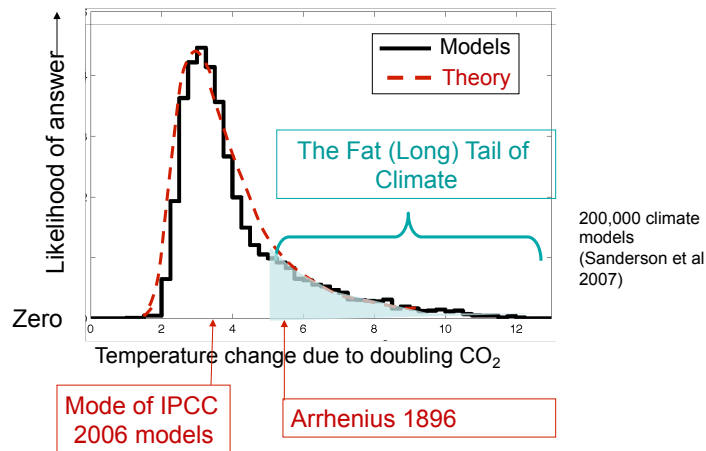

The fat tail means there is a 20% chance the response to increasing CO<sub>2</sub> will be *at least twice as great* as that projected by the consensus IPCC

# The Fat Tail of Climate Sensitivity

Many influential, *mainstream* economists have concluded that we cannot exceed an increase of 2-3°C in global temperature without catastrophic damages to the global economy



Prof. Lawrence Summers (Harvard)  
US Secretary of the Treasury (Clinton)  
Former Director, White House National Economic Council (Obama)

Prof. Marty Weitzman (Harvard)  
"among the most influential economists in the world" and often stated as an upcoming recipient of the Nobel Prize in Economics



"Climate change, at the fat tail, threatens to drive all of planetary welfare to disastrously low levels in the most extreme scenarios."



Sir Nicholas Stern (LSE)  
Fmr Chief Economist, World Bank. Chair of the Stern Review of Economics of Climate Change

The Executive Summary of the Stern Review on the Economics of Climate Change is here: [www.hm-treasury.gov.uk/sternreview\\_summary.htm](http://www.hm-treasury.gov.uk/sternreview_summary.htm)

# The Fat Tail of Climate Sensitivity

Many influential, *mainstream* economists have concluded that we cannot exceed an increase of 2-3°C in global temperature without catastrophic damages to the global economy

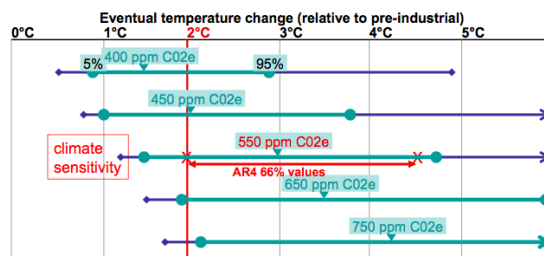

Source: Stern Review, 2006, Executive Summary, p. v.

Unfortunately, the Fat Tail of climate sensitivity means even 500ppm is terribly risky.

# Climate Engineering (aka Geoengineering)

- What is it?
- Why do it?
  - Large changes ahead (including some unforeseen)
- How do we stop the climate from changing without reducing CO<sub>2</sub> emissions?
  - Take CO<sub>2</sub> out of the atmosphere (unlikely)
  - Reduce sunlight to counter increased CO<sub>2</sub> due to human activity (climate engineering)
- General pros and cons of climate engineering

## Take CO<sub>2</sub> out of the air

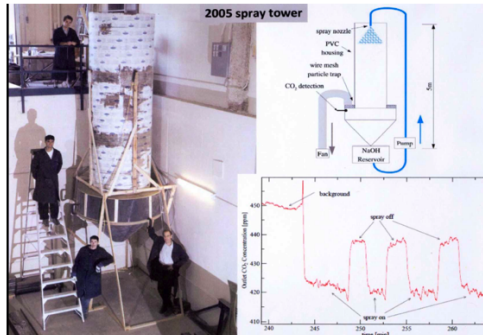

Source: David Keith, MIT talk, Sept. 16, 2008

Currently four ways to do this. None have left the prototype stage. All are projected to be astoundingly expensive.

## Carbon Capture and Storage

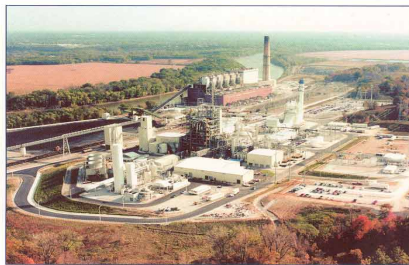

The Wabash River  
Coal Gasification Repowering Project

Graphics courtesy of DOE Office of Fossil Energy

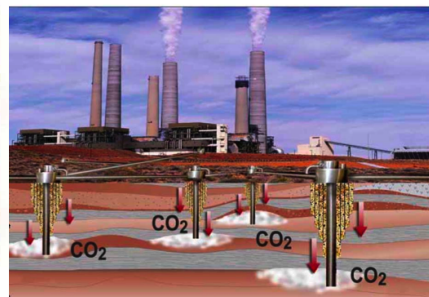

- Works for CO<sub>2</sub> emitted from coal, but not applicable to non-point sources (e.g., CO<sub>2</sub> emitted from oil)
- Makes energy from coal expensive compared to many other sources, including renewables

## Take CO<sub>2</sub> out of the air (cont)

- Stuff it into trees and make sure they don't rot
  - Requires management of organic material so it doesn't rot
  - Requires massive amount of land currently used for growing food to capture only a fraction of the required carbon

## Take CO<sub>2</sub> out of the air (cont)

- Fertilize the ocean with iron (a limiting nutrient) to promote photosynthesis and thus remove CO<sub>2</sub> from the atmosphere

- Downsides:

- All peer-reviewed published experiments to date show this doesn't work: after the phytoplankton grow they die, and most carbon goes right back into the atmosphere)
- Major disruption to the base of the food chain (leading to changed ecology and often red tides)

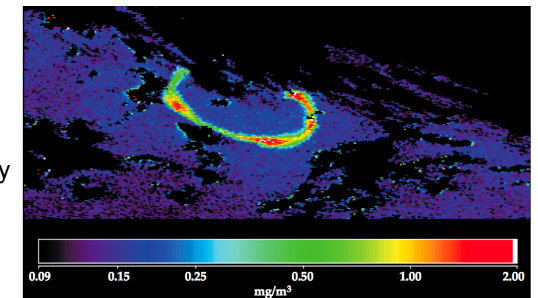

Phytoplankton bloom following an iron-fertilization experiment in the Southern Ocean. The area covered spans about 1 degree of latitude and 2 degrees of longitude. Color scale indicates the mass of chlorophyll per cubic meter of seawater, mostly contained in phytoplankton. (Image provided by the NASA Goddard Earth Sciences Data and Information Services Center.)

## Block enough sunlight to cancel warming due to increasing CO<sub>2</sub>

- Solar reflectors placed in outer space at a point where the gravitational field from the earth cancels that from the sun
  - Downside:
    - Launch alone cost ~10 trillion dollars
    - Once in place, impossible to remove. If they fail, it will take many years to replace them (and without the shading, the climate would warm dramatically)
- Mirrors orbiting the earth to reflect sunlight
  - Downside: Very expensive, a nightmare for space navigation, impossible to retrieve

## Block enough sunlight to cancel warming due to increasing CO<sub>2</sub>

The controlled enhancement of the the albedo and longevity of low-level maritime clouds

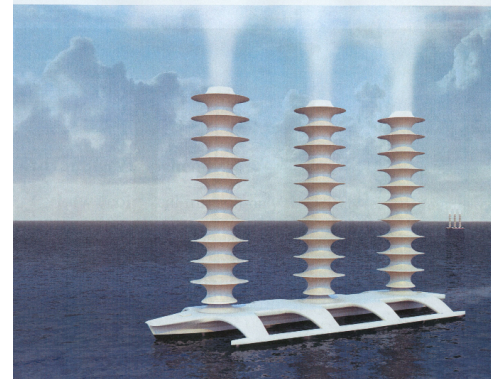

Cheap: 2-4 B\$US/year

- 3000 wind-powered ships
- Shoot a spray of very fine sea water into the clouds, making the cloud droplets smaller and thus more reflective of sunlight
- Basic idea: reduce uptake of solar energy by the oceans
- Approach works best in pristine (ocean) areas
- Downside:
  - clouds are the weak link in understanding climate change
  - Ocean continues to acidify
  - Once you start, you can never stop

## Block enough sunlight to cancel warming due to increasing CO<sub>2</sub>

- Place tiny particles in the stratosphere that reflect visible sunlight but don't absorb infrared radiation
- Nature does this ever so often: launching sulfur dioxide into the stratosphere that turns into sulfate particles
  - Particles reflects sunlight and cool the planet
  - Particles fall out after a year or two
- Upsides:
  - We know it works to cool (volcanoes do it)
  - Its cheap (~10 B\$ per year)



## Possible (unproven) option for getting 10Mt of sulfur aerosols in stratosphere each year

- Artillery: shooting barrels of particles into stratosphere with 16" Iowa Class naval guns
  - Three guns firing twice per minute for 10,000 yrs
  - Barrels replaced every 100 mins
  - "...surprisingly practical" (NAS 1992) (cost about 10B, or 0.1% of US GDP)



## The prototype plan for R&D, testing and deployment

Novim Study Group Report	
<u>CLIMATE ENGINEERING RESPONSES TO CLIMATE EMERGENCIES</u>	
<i>Study Group Meeting: August 10 to 15, 2008</i>	
<i>Report Publication: DRAFT 3.4 (December 2, 2008)</i>	
<i>Study Group Participants:</i>	
Jason J. Blackstock <sup>1</sup> , David Battisti, Ken Caldeira, Douglas M. Eardley, Jonathan I. Katz, David W. Keith, Aristides A. N. Patrinos, Daniel P. Schrag, Robert H. Socolow and Steven E. Koonin <sup>2</sup>	
<sup>1</sup> Report Lead Authors <sup>2</sup> Study Group Convenor	
TABLE OF CONTENTS	
EXECUTIVE SUMMARY.....	II
PRELUDE: THE CONTEXT OF THE "SHOULD" DEBATE ABOUT CLIMATE ENGINEERING RESEARCH.....	IV
PREFACE.....	VI
A NOTE ON CONFLICTS OF INTEREST.....	VI
ACKNOWLEDGEMENTS.....	VII
STUDY GROUP PARTICIPANTS.....	VII
<b>1 INTRODUCTION AND CONTEXT.....</b>	<b>1</b>
1.1 THE POSSIBILITY OF CLIMATE EMERGENCIES.....	1
1.2 CLIMATE ENGINEERING AS A POTENTIAL—BUT UNCERTAIN—RESPONSE TO CLIMATE EMERGENCIES.....	1
1.3 REDUCING THE UNCERTAINTIES: THE FOCUS AND LIMITED SCOPE OF THIS STUDY.....	2

Theoretical Physicist,  
JASON member

Chief Scientist BP, US  
Secretary of Energy,  
now US Govn R&D for  
National Security

... has been delivered to the Pentagon

## Block enough sunlight to cancel warming due to increasing CO<sub>2</sub>

- Downsides:
  - It is cheap: many individual countries could do it
  - Milky sky (impact on biology and agriculture unknown)
  - Climate response doesn't exactly cancel the CO<sub>2</sub> response. For example:
    - it will probably enhance the likelihood that the Antarctic ice sheet becomes unstable)
    - Global precipitation decreases
    - Ocean continues to acidify (disrupting the base of the food marine chain)
  - Once you start, you can never stop**



## Climate Engineering (aka Geoengineering)

- What is it?
- Why do it?
  - Large changes ahead (including some unforeseen)
- How do we stop the climate from changing without reducing CO<sub>2</sub> emissions by climate engineering?
  - Take CO<sub>2</sub> out of the atmosphere (unlikely )
  - Reduce sunlight to counter increased CO<sub>2</sub> due to human activity
- General pros and cons of climate engineering

## General arguments for doing climate engineering

- Reducing CO<sub>2</sub> emissions is a Herculean political, social, economic and technological feat. Our present efforts have fallen far short of what is required to stabilize and reduce CO<sub>2</sub> to avoid large, unprecedented changes in climate that are very likely to have serious deleterious impacts on the global economy, society and the environment.
- Increasing greenhouse gases may cause climate changes that create climate emergencies: impacts that are not presently deemed likely or were not anticipated, but that have dire consequences.

## General arguments *against* doing climate engineering (including sun shading by stratospheric aerosols)

- The ocean will continue to acidify
- Technology is still in its infancy
  - We have a large community of scientist and ~50 years of experience on the global warming problem (with modest progress on reducing uncertainty)
  - A handful (10-20) of scientist have spent ~5-10 years thinking about what might happen if we deploy a particular climate engineering solution. The science is in its infancy, and all of the work being done in the US is funded by private sources.
- The climate system is inherently complex and the possibility of “[unanticipated] harmful side effects” is too large for any intentional human intervention to *ever* be considered safe.
- Even when emissions of CO<sub>2</sub> go to zero, we will have to continue to deploy the aerosols until the CO<sub>2</sub> returns to a safe level (> 1000 years)
- Once you start, you can never stop.

## General arguments *against* doing climate engineering (including sun shading by stratospheric aerosols)

Stopping either deliberately (an adverse side-effect is discovered, or a terrorist act) or unintentionally (loss of capability, political will) will result in disaster.

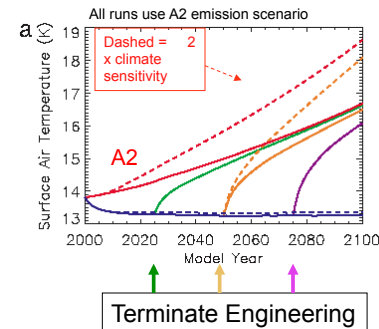

- If sun shade technology is deployed to cancel warming due to large increases in CO<sub>2</sub>, then a temporary failure in deployment (unintentional or not) would cause the planet to warm greatly and catastrophically  
e.g., 1 - 4 °C in 10 years  
(cf. 20<sup>th</sup> century at 0.09 °C/10 yrs, or nature at 4 °C/10,000 yrs)

Calderia and Wood 2008

## Profound and unaddressed issues associated with climate engineering

- Who decides if it should be deployed, and at what level? Who decides if it should be stopped?
  - What if a country that would benefit decides to do it on its own, even though it harms another country?
- There are important cultural, ethical, legal, political and economic implications of climate engineering. How will they be balanced?
- Moral hazard:
  - If we have an alternative solution to carbon management, we will be less inclined to pursue efforts to reduce carbon emissions
- We can't rule out unanticipated harmful and perhaps irreversible consequences (e.g., CFCs and the Ozone Hole)

## WILL CLIMATE ENGINEERING HAPPEN?

- It is incredibly easy and (in the short term) inexpensive compared with reducing emissions and transitioning to a non-carbon emission economy
  - Cost is ~10B/yr compared to ~200B/yr to reduce carbon emissions
  - Cost is less than 0.1% GDP for US, less than 2% for about 30 countries
- Players who are currently influential and have a lot to lose if greenhouse gas emissions are limited/reduced (oil and gas companies, libertarians) don't lose from climate engineering
- Whoever holds the contract for CE solution has huge influence and unlimited profits for a millennium
  - E.g., Projects are already being developed by the major defense contractors and venture capitalists, including some of the richest people in the world

## WILL CLIMATE ENGINEERING HAPPEN?



**Bill Gates**  
Also owns Carbon Engineering



**Sir Richard Branson**  
Virgin Atlantic Airways



**Murry Edwards**  
Canadian Tar Sands Magnate

... and other oligarchs are funding groups of people to develop the technology

## Video resources on climate engineering

- David Keith's TED talk:  
[http://www.ted.com/talks/david\\_keith\\_s\\_surprising\\_ideas\\_on\\_climate\\_change.html](http://www.ted.com/talks/david_keith_s_surprising_ideas_on_climate_change.html)
- The recent MIT conference on climate engineering  
<http://web.mit.edu/esi/symposia/symposium-2009/symposium2009-presentations.html>

I particularly enjoyed the talk by Prof Layzer, "What's the "Rational" Choice?: Risk, Values and the Politics of Geoengineering"